



City of Joliet

Utility Design & Inspection

Policy Manual

ADOPTED: By Ordinance #2019-17934, modified by Ordinance #2022-18418

**City of Joliet Department of Public Utilities
150 W. Jefferson Street,
Joliet, IL 60432**

January 2023

Table of Contents

1	INTRODUCTION	6
1.1	DESIGN MANUAL PURPOSE AND GOAL	6
1.2	DESIGN MANUAL INTERPRETATION.....	7
1.3	DESIGN MANUAL REVISION	7
1.4	AUTHORITY	7
1.5	STANDARD DETAILS AND SPECIFICATIONS	7
1.6	PERMITS AND FEES.....	7
2	GENERAL STANDARDS.....	8
2.1	WATER AND SEWER EASEMENTS.....	8
2.2	UTILITY INSTALLATION RESTRICTIONS	8
2.3	CRITICAL CUSTOMERS.....	9
2.4	GIS DATA STANDARDS.....	10
2.5	GIS GENERAL REQUIREMENTS.....	13
2.5.1	Equipment Requirements	13
2.5.2	Setup and Collection Requirements	13
2.5.3	Data Collection Features	13
2.5.4	Submittals	13
2.5.5	Data Acceptance	13
2.6	DRAWING REQUIREMENTS	13
3	WATER SYSTEM DESIGN CRITERIA.....	13
3.1	GENERAL WATER SYSTEM DESIGN REQUIREMENTS	13
3.1.1	Design Approval	13
3.1.2	IEPA Permit Required	14
3.1.3	Public and Private Water Mains.....	14
3.1.4	Basis of Design	14
3.2	WATER MAIN REQUIREMENTS.....	14
3.2.1	Water Distribution and Transmission Material.....	14
3.2.2	Location in the Public Right-Of-Way.....	15
3.2.3	Water Main Sizing.....	15
3.2.4	Water Main Taps (4" and Greater).....	15

3.2.5	Water Main Taps (<4")	15
3.2.6	Joint Restraint	16
3.2.7	Oversizing Requirements	16
3.2.8	Limits of Installation.....	16
3.2.9	System Looping	16
3.2.10	Underground Locating Requirements	16
3.2.11	Pipe Marking Tape.....	16
3.3	WATER MAIN SEPARATION	17
3.3.1	Horizontal Separation.....	17
3.3.2	Vertical Separation.....	17
3.3.3	Depth of Cover	18
3.4	WATER SYSTEM SERVICES	18
3.4.1	Water Service Material	19
3.4.2	Water Service Line Sizing	19
3.4.3	Water Supply Control Valves	19
3.4.4	Water Meter Requirements	20
3.4.5	RPZ Valve Requirements	21
3.4.6	Master Metering	22
3.4.7	Connecting to Existing Water Mains	22
3.4.8	Water Service Connections	22
3.4.9	Abandoning Existing Services.....	22
3.5	FIRE PROTECTION REQUIREMENTS.....	23
3.5.1	Fire Protection Supplies.....	23
3.5.2	Public Fire Flow Requirements.....	23
3.5.3	Private Fire Protection Requirements.....	23
3.5.4	Fire Hydrant Requirements.....	24
3.6	WATER SYSTEM VALVE REQUIREMENTS	24
3.6.1	Valve Boxes and Valve Vaults.....	24
3.6.2	Valve Locations.....	24
3.7	WATER SYSTEM CASING REQUIREMENTS.....	25
3.7.1	Water Main Casing Pipes	25
3.7.2	Casing Pipe Material	25
3.7.3	Sizing of Casing Pipes	26
3.8	WATER SYSTEM INSPECTION REQUIREMENTS	26
3.8.1	Water System Testing Requirements	26
3.8.2	Water System Inspection Requirements	28

4	SANITARY SYSTEM DESIGN CRITERIA.....	28
4.1	GENERAL SANITARY SYSTEM REQUIREMENTS.....	28
4.1.1	Design Approval.....	29
4.1.2	IEPA Permit Required.....	29
4.1.3	Public and Private Sanitary Sewers.....	29
4.1.4	New Business Wastewater Survey.....	29
4.1.5	Wastewater Discharge Permit Determination.....	30
4.2	SANITARY SEWERS REQUIREMENTS.....	30
4.2.1	Sanitary Sewer Pipe Materials.....	30
4.2.2	Location in the Public Right-Of-Way.....	30
4.2.3	Curvilinear Alignment of Sanitary Sewers.....	30
4.2.4	Sewer and Water Main Separation.....	30
4.2.5	Depth of Pipe Cover.....	30
4.2.6	Overhead Sewers.....	30
4.2.7	Sanitary Sewer Sizing.....	31
4.2.8	Oversizing and Extra Depth Requirements.....	31
4.2.9	Sanitary Sewer Minimum Slopes.....	31
4.2.10	Sanitary Sewer Maximum Slopes.....	32
4.2.11	0.10 Foot Drop Across Manholes.....	32
4.2.12	Limits of Installation.....	32
4.2.13	Pipe Marking Tape.....	32
4.3	SANITARY SEWER MANHOLE REQUIREMENTS.....	32
4.3.1	Manhole Location and Spacing.....	32
4.3.2	Manhole Sizing Requirements.....	33
4.3.3	Invert Elevations in Manholes.....	33
4.3.4	Drop Manholes.....	34
4.3.5	Requirement for Inspection Manholes and Clean-Outs.....	34
4.3.6	Grease/Oil/Sand Trap Manholes.....	34
4.3.7	Polymer Manholes.....	35
4.4	SANITARY SEWER CONNECTION REQUIREMENTS.....	35
4.4.1	Connecting to existing sewer.....	35
4.4.2	Extension of Existing Services.....	36
4.4.3	Disconnection of Existing Services.....	36
4.5	SANITARY SEWER CASING REQUIREMENTS.....	36
4.5.1	Casing Pipes.....	36
4.5.2	Casing Pipe Material.....	37
4.5.3	Sizing of Casing Pipes.....	37

4.6	LIFT STATION REQUIREMENTS.....	37
4.6.1	Force Main Requirements	37
4.6.2	Facility Requirement.....	38
4.7	SANITARY SEWER INSPECTION REQUIREMENTS	38
4.7.1	Sanitary Inspection Procedures.....	38
4.8	FENCING REQUIREMENTS	40
4.8.1	Required Fence Locations	40
4.8.2	Design and Approval Procedure	40
4.8.3	Visual Screening Requirements	40
4.8.4	Dimensions.....	40
4.8.5	Structural Design	41
4.8.6	Architectural Design, Colors, Materials.....	41
5	DESIGN REFERENCES.....	42
5.1	DESIGN REFERENCES.....	42

LIST OF TABLES

<u>Table</u>	<u>Page No.</u>
1 Fire Flow Requirements.....	23
2 Water System Casing Pipe Material.....	25
3 Sanitary Sewer Minimum Slopes.....	31
4 Minimum Manhole Sizing Requirements	33
5 Sanitary Sewer Casing Pipe Material	37
6 Fence Design Standards	41

LIST OF APPENDICES

Appendix A	Approved Materials List
Appendix B	Standard Details
Appendix C	Lift Station Design Requirements
Appendix D	General Notes
Appendix E	Pretreatment Questionnaire
Appendix F	Critical Customer Questionnaire
Appendix G	Project Closeout Checklist
Appendix H	Lift Station Closeout Checklist
Appendix I	Water Tower Mounting Standards

1 INTRODUCTION

1.1 DESIGN MANUAL PURPOSE AND GOAL

The City of Joliet takes great pride in providing clear communication to the community regarding City guidelines. The following guidance document is intended to provide an easy reference for the general public, engineers, consultants, and developers performing business in the City. The manual is intended to provide clear and consistent design requirements to be as efficient as possible with the design and review process.

The standards provided in this document also support consistent standards when building within the City right-of-way or easement. Although intended to be as comprehensive as possible, the reader of this document should not expect every plausible design instance to be included.

The City of Joliet regularly updates this manual to reflect best available design practices.



James Capparelli – City Manager



Allison Swisher, P.E., Director of Public Utilities



Tony Anczer, P.E., Deputy Director - Engineering



Nick Cornick, Deputy Director - Plant Operations



William Baltz, Deputy Director - Field Operations

1.2 DESIGN MANUAL INTERPRETATION

This manual is composed of written engineering standards, references to established standards of other organizations and agencies, and standard details of the Joliet Department of Public Utilities. The Director of the Joliet Department of Public Utilities, whose interpretation shall be binding and controlling in its application, shall make the interpretation of any section or of differences between sections. NOTE: Any deviations from the standards in this manual shall require a technical appeal to the Joliet Director of Public Utilities.

1.3 DESIGN MANUAL REVISION

This manual may be revised periodically. Revisions will be posted on the City of Joliet website. In order to review revisions, go to the following website:

<https://www.joliet.gov/government/departments/public-utilities/development-guidance>

1.4 AUTHORITY

The design standards set forth in this manual are adopted pursuant to the authority granted in the City of Joliet code.

1.5 STANDARD DETAILS AND SPECIFICATIONS

The City of Joliet has developed standard specifications and details that are included as Appendices to this design manual. The following are the required specifications and detail references that shall be utilized in all developments in the City of Joliet:

1. Appendix A – Approved Materials List
2. Appendix B – Standard Details
3. Appendix C – Lift Station Design Requirements
4. Appendix D – General Notes
5. Appendix E – Pretreatment Questionnaire
6. Appendix F – Critical Customer Questionnaire
7. Appendix G – Project Closeout Checklist
8. Appendix H – Lift Station Closeout Checklist
9. Appendix I – Water Tower Antenna Mounting Standards

1.6 PERMITS AND FEES

Developers will pay all required permit, review, and inspection fees consistent with all applicable codes and policies of the City of Joliet prior to commencing work.

2 GENERAL STANDARDS

2.1 WATER AND SEWER EASEMENTS

All public water system and sanitary system components that are not located within a public right of way shall be placed in a public utility and drainage easement, minimum 15-foot wide or as directed by the Department of Public Utilities, to the City of Joliet. The easement shall be granted to the City either through a recorded plat of subdivision or a recorded plat of easement. The City shall be granted access to these easements if not directly adjacent to public right-of-way.

At the discretion of the Director of Public Utilities, the City may require additional easements for future maintenance or repair of the water or sanitary systems, even those portions which may be located within the public right-of-way. For example, the City may have a deep sanitary sewer located within the public right-of-way. However, the City may require a public utility and drainage easement parallel to the edge of the right-of-way to accommodate future repair of the sanitary sewer if it ever needs to be excavated and repaired.

2.2 UTILITY INSTALLATION RESTRICTIONS

No building will be allowed to encroach on a water or sewer easement.

Water and sanitary sewer separation from other utilities must maintain an 18-inch vertical separation and 6-foot horizontal separation unless approved by the Director of Public Utilities.

Regardless of the easement width, buildings shall have a sufficient setback from the water or sewer pipe such that buildings, building foundations or building slabs will not be undermined or damaged by a water or sewer main break or subsequent repair.

Buildings, building slabs or structures proposed outside of the easement but parallel to a sewer main at a horizontal distance less than equal to the depth (invert) of the sewer main, shall be required to submit structural and soil calculations signed and sealed by an Illinois Registered Professional Engineer. This report shall verify integrity of the proposed structure under the condition of a sewer main failure.

Buildings, building slabs or structures proposed outside of the easement but parallel to a water main within 12 feet, shall be required to submit structural and soil calculations signed and sealed by an Illinois Registered Professional Engineer. This report shall verify integrity of the proposed structure under the condition of a water main failure.

No City Utility will be installed in a location that creates an undue hardship to the utility to maintain the Utility. Examples include: underneath a berm, in a low area that will have

periodic ponding, in a known ditch that conveys water during storms, and under parking lots on private property.

2.3 CRITICAL CUSTOMERS

“Critical Customers” are defined as consumers or service connections that are critical to community resiliency (public safety or health), or demand a large volume of water to sustain economic resiliency, or service a susceptible population such as and specific to the City of Joliet or the Region:

- First Responder Organizations / Police / Fire / EMTs
- Dental Care and Oral Emergency Centers
- Hospitals / Medical Centers (including dialysis centers)
- Local / Federal Government Facilities necessary for public safety / health
- Mass Transit Stations
- Nursing Homes / Assisted Living / Homeless Shelters
- Potable Water Haulers
- Power Provider
- Public Shelters / Cooling Centers / Water Parks / Municipal Pools
- Radio / TV Broadcast Centers
- State / Local Emergency Management Agencies
- Universities / High Schools / Elementary / Middle Schools / Preschool and Day Cares
- Any facility that is converted into a critical care facility.

Notifying all impacted customers of a water or sewer emergency is one of our highest priorities, but specifically knowing where critical customers are and how to communicate with them assists the whole community in being resilient and in protecting susceptible populations. Emergency notifications are a time sensitive endeavor, and it is important for us to be able to contact critical customers quickly. Filling out the Appendix F – Critical Customer Questionnaire helps the City by providing up to date locations and contact information for a critical customer facility. If the facility intended for construction is defined as a critical customer facility, the facility shall be required to provide redundant system infrastructure to protect the occupants of that facility.

2.4 GIS DATA STANDARDS

The City of Joliet uses GIS (Geographical Information System) technologies to store, manage, and maintain geographic/spatially related data. Likewise, most of the civil engineering community has evolved to the point where the predominating design environment is computer aided design and drafting (CAD). It is the goal of the City to use GIS and CAD technologies to acquire as-built data for all infrastructure installed. **It is the responsibility of the developer to deliver complete and accurate GIS data prior to acceptance of any development.** The standards below will guide integration of digital engineering CAD drawings into the GIS environment, while maintaining the integrity and positional accuracy of the data.

Blank attribute tables in geodatabase format will be provided by the City for water and sanitary systems. The fields are already formatted and are to be used for providing attribute information that corresponds to the infrastructure.

Requirements for Digital CAD and GIS As-Built Submittals:

- All data shall be in coordinate system: NAD_1983_StatePlane_Illinois_East_FIPS_1201 Feet.
- The scope of mapped infrastructure is to include all water infrastructure, all sanitary sewer infrastructure, public storm sewer infrastructure, and all storm sewer on the outflow side of a detention basin.
- The scope of applicable projects includes all developments with public water and sewer mains and all site projects greater than one (1.0) acre.
- Do not rename any of the attribute tables.
- Do not alter the original formatting and structure of the attribute tables or replace them with similar tables.
- Use the correct table for each sewer line, structure type, or other feature.
- All required fields filled in with appropriate data. Additional information entered in the non-required fields is also helpful.
- Correct units and precision used for pipe diameter, pipe length, upstream elevation, etc.
- Correct code from the lookup tables used when required. The lookup tables can be found in in the metadata associated with the geodatabases. Whenever possible use the code that most accurately describes the item.
- Removed or abandoned features need to be denoted as such within the attribute table.
- All sanitary sewer and storm pipes shall be drawn in the direction of flow.
- Collect GPS points of structures prior to burying.

General Notes:

- The lookup tables are not linked to the attribute tables, so they are used as a reference.
- Adhere to the requirements in any “type” column in the Attribute Table Requirements.
- This formatting must be adhered to for the attribute information to be used properly.
- Excel (.xls) files can be accepted for the attribute tables if the formatting is kept the same and none of the field names are changed or deleted, however the original geodatabase file format is preferred.
- If it is unclear which attribute tables should be used or how to code any of the required fields, please consult with the City prior to delivering your digital data submission.
- Data shall be submitted in full GIS geodatabase format or AutoCAD drawings with Civil 3D Models.
- Refer to external City documents regarding more detailed CAD and GIS standards and guidelines.
- **All files are to be submitted at both the design stage (at the time of plan approval) and as-built stage (upon completion of construction).**

2.5 GIS GENERAL REQUIREMENTS

The Developer is to provide real-time utility and infrastructure asset data for delivery into the City of Joliet’s Geographic Information System (GIS) for the water distribution system and the sanitary sewer system. The Contractor is required to utilize GPS equipment to obtain selected project datapoints, assets, and real-time as-built utility information during construction.

2.5.1 Equipment Requirements

Equipment requirements for data collection shall include GPS Rovers that meet the minimum accuracy and real-time GIS integration requirements. Equipment used to collect this data shall be properly calibrated and capable of meeting a minimum accuracy of 10 mm horizontally and 20 mm vertically (Trimble R2, DA2, or equal).

The Department of Public Utilities carries some inventory of these GPS Rovers that are available to contractors completing work in the City as inventory allows. See the City GPS Loaner Policy for additional information.

In addition to the GPS Rover, a dedicated smart phone or tablet with 5G cellular connectivity to be provided by the Contractor is needed for the GPS unit to communicate. A training video will be provided showing how to operate the GPS unit, however the City will not provide technical support of operation of the GPS units. If support is needed, contractors can hire a GIS consultant approved by the City knowledgeable of the process.

The GPS equipment shall integrate and utilize the Esri ArcGIS Field Maps Application (downloadable from App Store and Google Play) with a City provided Project Map. The

Contractor will provide real-time connectivity and data updates using a cellular data connection with the GPS unit. GPS units must be able to deliver real time, cellular networked data to an ESRI ArcGIS Online portal established by the City. The Contractor will have access to collected data and can utilize this GIS information to assist them throughout the project. The Contractor will use a City provided ESRI license.

2.5.2 Setup and Collection Requirements

Contractor shall obtain survey data during or immediately after installation of the utility. For open trench and exposed water main or sewer utilities, data points shall be obtained at intervals of 50 feet and at directional changes with a minimum of 2 points. Utilities that are bored (trenchless) will be surveyed at the exposed pit locations at both ends and along the boring route with depths manually inputted every 10 feet from the above ground locating devices. For water and sanitary services, data points shall be obtained at intervals of 10 feet and at directional changes with a minimum of 2 points.

Data collection with the GPS device shall be completed by the Contractor on a real-time basis as the project is being constructed. The Contractor shall verify that data is being collected in real-time in the provided GIS portal (simple website link) on a regular basis, no less than two times per day.

Contractor shall have a surveyor establish GPS control points, and the contractor shall check in daily (beginning of day) to verify and maintain calibration of the device.

At least 95% of collected data must meet GPS accuracy requirements. Data not meeting this standard will be required to be exposed and surveyed again until this standard is met.

2.5.3 Data Collection Features

The following features are required to be collected by the Contractor during construction for the purpose of delivering GIS Digital As-Builts:

1. Water main, services, fittings, valves, hydrants, corporation stops, curb stops, structures, b-boxes, and related features (horizontal, vertical elevation, top of pipe, sizes, model data)
2. Proposed sanitary sewer, services, manholes, cleanouts, and related features (horizontal, vertical elevation, top of pipe, sizes, model data)
3. Exposed Sanitary Services (horizontal, vertical elevation, sizes, regardless of type)
4. Connections to existing utilities
5. Any other proposed or modified underground utility work or related feature.

Final GPS survey code and data input requirements will be provided at project start-up.

2.5.4 Submittals

Digital Data Collection will be conducted in real-time during construction and visible within the ArcGIS Online portal. No final GIS package delivery will be required of the contractor (final as-built survey is still required).

The City will finalize data collection by completing final utility connected linework for the purpose of delivering GIS feature classes or shapefiles compatible with ESRI. Utility lines connected shall include all identified attributes. If needed, the Contractor will assist the City and clarify final pipe data and connections within GIS.

2.5.5 Data Acceptance

At time of project completion, the City will verify that all data has been collected satisfactorily. Failure to do so will be grounds for not accepting the project or releasing the surety until the data is satisfactory. If, at any time, the Contractor fails to perform this work, the City reserves the right to utilize an outside provider and charge the work to the project owner prior to releasing the surety and/or accepting the project.

2.6 DRAWING REQUIREMENTS

All drawings prepared for the City of Joliet Public Utilities Department will include the general notes found in Appendix D – General Notes and the Standard Details as Provided in Appendix B of this Design Manual. All drawings shall be in compliance with the design criteria as outlined in this manual and formatted for 24" x 36" full-size production. Drawings will be submitted in both digital (PDF) and hardcopy (5 full-size) formats.

All projects shall require the submittal of As-Built drawings. As-built drawings shall be red-line updated monthly during construction and will be subject to review by City inspectors. Drawings submitted upon project completion shall show the as-built location of all utilities and utility structures and be provided in AutoCAD and PDF format.

3 WATER SYSTEM DESIGN CRITERIA

3.1 GENERAL WATER SYSTEM DESIGN REQUIREMENTS

3.1.1 Design Approval

The Joliet Department of Public Utilities shall approve all designs and shall alter design requirements only as necessary to meet the City water system plan. The Department of Public Utilities shall review and comment on all designs in conjunction with review specialists as required to interpret plans. All materials will conform to Appendix A – Approved Materials List of this Design Manual.

The City of Joliet's Standard Details, as currently adopted by the Department of Public Utilities, should be used in all construction plans. The standard details are found in Appendix B- Standard Details of this Design Manual. Any modifications or substitutions to these standard details require approval from the Director of Public Utilities.

3.1.2 IEPA Permit Required

All public water main extensions require an IEPA Construction permit, prior to construction. It is the responsibility of the interested party to prepare the necessary documents to secure all permits. The City of Joliet will review all permit applications and sign only when all information is correctly provided. All required permits must be obtained and provided to the Joliet Director of Public Utilities prior to commencing any utility work.

3.1.3 Public and Private Water Mains

During construction and prior to City acceptance, it is the sole responsibility of the developer to maintain any new infrastructure that is proposed under the permit. When the water distribution system is complete and the improvements have been formally accepted by the City, the Joliet Department of Public Utilities shall be responsible for the repairs and maintenance of all Public water mains. Maintenance and repairs for private components shall be the responsibility of the property owner, or property owner's association. In such cases where the City performs maintenance or repairs on the private water distribution system, the City reserves the right to charge the property owner for necessary work.

NOTE: All engineering plans shall clearly differentiate between all portions of the public and private water distribution system.

3.1.4 Basis of Design

All water systems shall be designed using the Hazen-Williams method. The coefficient of roughness shall equal one hundred ($c = 100$).

3.2 WATER MAIN REQUIREMENTS

3.2.1 Water Distribution and Transmission Materials

Ductile iron pipe shall be cement-lined, have a minimum Class 52 thickness designation, and polyethylene encasement. Water main shall be zinc coated. For information regarding applicable ANSI, AWWA, and ASTM designations, refer to Appendix A – Approved Materials List of this Design Manual.

PVC C900 pipe may be allowed for pipe sizes 4 through 12 inches upon approval of the Director of Public Utilities. It shall be DR 18 with rubber-ring gasket bell end or plain end with elastomeric gasket coupling, cast iron equivalent outside diameter, material cell classification 12454. For information regarding applicable ANSI, AWWA, and ASTM designations, refer to Appendix A – Approved Materials List of this Design Manual.

As per IEPA Title 35 Section 653.119, water mains and water service lines shall be protected against the entrance of hydrocarbons through diffusion through any material used in construction of the line. In areas that may be ascertained to be vulnerable to contamination, ductile iron water main with either nitrile rubber gaskets or fluoroelastomer rubber gaskets (Vitron®) must be used for a distance of at least 25 feet from any petroleum pipeline or contaminated soil. Environmental Site Assessments completed by a certified environmental independent consultant may be required in areas of questionable soil characteristics.

3.2.2 Location in the Public Right-Of-Way

Water mains shall be generally located on the north and west sides of the public right-of-way, or as directed by the Director of Public Utilities. All designs will provide for the most efficient system design while considering ease of future maintenance. All efforts will be made to minimize the amount of pipe that is under PCC pavement and parking stalls.

3.2.3 Water Main Sizing

Water mains shall be constructed of 8-inch diameter or 12-inch diameter pipe, or as directed by the Department of Public Utilities. No water mains less than 8-inch diameter will be allowed without approval from the Director of Public Utilities.

3.2.4 Water Main Taps (4" and Greater)

Use two-piece bolted sleeve ductile iron or stainless-steel type with mechanical joints. Only under special circumstances will the stainless-steel type be allowed to be substituted for the cast iron sleeve. Provide joint accessories. See Appendix A – Approved Materials List for approved manufacturers.

The City of Joliet Water Department shall be responsible for completing all taps to existing water mains. Contractor will be responsible for calling 815-724-4220 to schedule an appointment with the Water Department. Appointments are available on Tuesdays and Thursdays.

3.2.5 Water Main Taps (<4")

For 1" taps, a direct tap on ductile iron pipe may be made using a 1" corporation stop.

For 1.5" and 2" taps, a tapping saddle with U bolts will be required.

Tapping saddles with U bolts will be required for all PVC pipe connections.

The City of Joliet Water Department shall be responsible for completing all taps to existing water mains. Contractor will be responsible for calling 815-724-4220 to schedule an appointment with the City Department of Public Utilities. Appointments are available on Tuesdays and Thursdays.

3.2.6 Joint Restraint

All mechanical joint fittings shall have restraining glands installed. Lengths of pipe restraint shall be determined from manufacturers' installation specifications.

3.2.7 Oversizing Requirements

It may be determined that the water main be oversized in order to provide service to additional benefiting properties. Consideration of oversizing pipes will be made on a case by case basis at the sole discretion of the Director of the Public Utilities Department.

3.2.8 Limits of Installation

At a minimum, water main shall extend across the frontage of the property, at the developer's cost, such that a connection could be made with minimal disturbance in the future. In some cases, the City may require that the water main be installed from one corner to the diagonally opposite corner, at the developer's cost.

All water main stubs for future extension shall terminate with a valve and hydrant. Restrained joints shall be located 40 feet from the capped end.

3.2.9 System Looping

Each 8- inch diameter water main shall be looped at a distance not to exceed 1,000 feet.

Each 12- inch diameter and larger water main shall be looped at a distance not to exceed 3,000 feet.

No dead-end water mains shall be allowed and hydrant leads must comply with current IDPH guidance.

3.2.10 PVC Water Main Locating Requirements

All PVC water main installed shall have the ability to be located aboveground. Tracer wire and location safety tape are both required. Install tracer wire taped to the buried PVC pipe at the 10:00 position on the east or north side of the water main. The tracer wire shall provide a continuous path which can locate the buried installation by inducing a current to the tracer wire. Refer to the Water System standard details for additional requirements on installation of locating wire.

3.2.11 Pipe Marking Tape

Provide detectable marking tape manufactured for use in underground locations to be installed in open cut trenches buried one to two feet below grade for all water main materials.

3.3 WATER MAIN SEPARATION

Water mains and water service lines shall be protected from sanitary sewers, storm sewers, combined sewers, house sewer service connections, drains, and sanitary sewer force main.

3.3.1 Horizontal Separation

Water mains shall be laid at least 10 feet horizontally from any existing or proposed drain, storm sewer, sanitary sewer, combined sewer or sewer service connection.

Water mains may be laid closer than 10 feet to a sewer line when:

- Local conditions prevent a lateral separation of ten feet;
- The water main invert is at least 18 inches above the crown of the sewer; and
- The water main is either in a separate trench or in the same trench on an undisturbed earth shelf located to one side of the sewer.

When it is impossible to meet the conditions above, the drain or sewer shall be constructed of slip-on mechanical joint cast or ductile iron pipe, or PVC SDR 26 pipe meeting the requirements for water main. The drain or sewer shall be pressure tested to the maximum expected surcharge head before backfilling with no leakage allowed in the area of required water main protection. A City of Joliet representative shall witness this testing.

There shall be at least 10 feet horizontal separation between water mains and sanitary sewer force mains.

Water mains must be separated at least 25 feet from septic tanks, disposal fields, seepage beds, sewage lift stations, fuel storage tanks, oil storage tanks, and chemical storage tanks.

3.3.2 Vertical Separation

A water main shall be laid so that its invert is 18 inches above the crown of the drain or sewer whenever water mains cross storm sewers or sewer service connections. The vertical separation shall be maintained for that portion of the water main located within 10 feet horizontally or any sewer or drain crossed. A length of water main pipe shall be centered over the sewer to be crossed with joints equidistant from the sewer or drain.

The sewer shall be constructed of slip-on or mechanical joint cast or ductile iron pipe, or PVC SDR 26 pipe, meeting the requirements for water main when:

- It is impossible to obtain the proper vertical separation as described above; or
- The water main passes under a sewer or drain.

A vertical separation of 18 inches between the invert of the sewer or drain and the crown of the water main shall be maintained where a water main crosses under a sewer. Support the sewer or drain lines to prevent settling and breaking of the water main.

If the invert of the water main is not 18 inches above the crown of the sewer when the pipes cross, a casing pipe can be installed around either the water main or sewer in lieu of constructing the sewer with water main equivalent pipe. The casing pipe must be a material that is approved for use as water main. The casing must extend on each side of the crossing at least 10 feet as measured at right angles from the outside edge of water main pipe to the outside edge of the sewer pipe. Pipe support shall be provided within the casing pipe and ends of the casing shall be filled with an approved non-shrink grout.

At crossings when the invert of the water main is not 18 inches above the crown of the storm sewer, and the sewer crossed the water main at right angles, the storm sewer can be constructed with reinforced concrete pipe using flexible gasket joints meeting ASTM C-361 or ASTM C-443 instead of providing a casing pipe or constructing the storm sewer with water main equivalent pipe. If gasketed storm sewer piping is proposed, it shall be installed between adjacent storm structures. The drain or sewer shall be pressure tested to the maximum expected surcharge head before backfilling with no leakage allowed in the area within 10 feet of the water main. A City of Joliet representative shall witness this testing.

Construction shall extend on each side of the crossing until the distance from the water main to the sewer or drain line is at least 10 feet as measured at right angles from the outside edge of the water main pipe to the outside edge of the sewer pipe.

Where a water main passes over an existing or proposed force main, an 18- inch vertical separation shall be provided at the crossing. (Note: A force main shall not be allowed to be above the water main at the crossing.)

3.3.3 Depth of Cover

All pipe shall be laid to a minimum depth of 5.0 feet measured from the proposed ground surface to the top of the pipe, unless specifically allowed otherwise in special circumstances by the Director of Public Utilities. If approved, the pipe shall be insulated with 2-inch exterior grade rigid insulation board. One 2-inch thick sheet of insulation shall be provided for each 6 inches of cover below the required 5- foot minimum depth and extend a minimum of 12 inches on each side of the water main. The insulation shall have a minimum R- value of R-9, and comply with ASTM C 578- 92 Type 1X.

3.4 WATER SYSTEM SERVICES

Water system services shall not cross a divided highway. In instances where water services are to be provided on both sides of a divided highway, parallel water mains shall be installed in the right of way.

No more than one building shall be supplied from one service pipe. Whenever possible, the service pipe shall enter the building in a direct line with the curb stop and tap. The service pipe shall not be allowed to cross onto an adjacent property. Said pipe shall be provided

with a valve before and after the water meter, not less than 1- foot inside of the wall or above the foundation floor (main building shutoff valve). The property owner shall be responsible for the maintenance, repair or replacement of the main shutoff valves.

Every building, except auxiliary buildings shall be individually metered.

All valves shall be arranged so that each line can be shut off from the exterior of the building.

Shut-off valve locations shall be shown on drawings.

3.4.1 Water Service Material

Service lines 2 inches or less ($\leq 2''$), inside diameter, shall be copper pipe, "Type K". All services 4 inches or greater ($\geq 4''$), inside diameter, shall be Class 52 ductile iron pipe with cement lining. See Appendix A – Approved Materials List of this Design Manual.

3.4.2 Water Service Line Sizing

The water service line sizing will follow the Illinois Plumbing Code. A minimum 1" service line is required to each unit. 3" service lines are not allowed.

3.4.3 Water Supply Control Valves

For residential, single family, control valves shall follow the following requirements:

1. Provide B-box shutoff valves for residential buildings.
2. Extend B-box to finished grade.
3. B-boxes must be located in the right-of-way and cannot be located in driveways or sidewalks.
4. Curb shall be stamped "W" in alignment with B-box.

For residential, multi-unit, buildings control valves shall follow the following requirements:

1. Separate complete water services shall be required from the water main for each. Each service line shall be separately metered.
2. Locate B-boxes together in the same order as the units.
3. Extend B-boxes to finished grade.
4. An address tag must be attached to each B-Box. Tags shall be 316 stainless steel, engraved with unit number/address.
5. In lieu of separate services and upon the approval of the Director of Public Utilities, meters may be allowed in a central place accessible 24-hour from the building exterior to Department of Public Utilities personnel for maintenance, inspection, or shutoff. Each meter must be supplied a locking valve approved by the City. The meter room will be allowed provided the door lock is keyed to conform with the City of Joliet master keying requirements. Alternatively, a Knox box may be installed.

For single-unit Commercial buildings control valves shall follow the following requirements:

1. Provide B-box shutoff valves.
2. Extend B-box to finished grade.
3. B-boxes cannot be located in driveways or sidewalks.
4. Curb shall be stamped “W” in alignment with B-box.

For Multi-unit Commercial buildings and units that share a single water service for fire protection and domestic supply control valves shall follow the following requirements:

1. Provide one main outside shutoff valve installed on the service line.
2. Buildings on slab must have a shutoff valve installed on the service line located in the outside wall of the building that faces the street and labeled “WATER” with 6” letters.
3. Unit meters shall be in a central place accessible from the building exterior to Department of Public Utility personnel for maintenance, inspection or shutoff. Each meter must be supplied a locking valve approved by the City. The door lock for the meter room must be keyed to conform with the City of Joliet master keying requirements. Alternatively, a knox box may be installed.
4. An address tag must be attached to each shut-off valve. Tags shall be 316 stainless steel, engraved with unit number/address.

3.4.4 Water Meter Requirements

Water Meters shall adhere to the following requirements:

1. Locate all meters in an accessible location for City personnel to inspect and replace. A crawl space, pit or under a stairway will not be considered accessible.
2. Provide protection from damage for water meter in non-residential buildings.
3. Provide full port ball valve within 16” of entering the building space and immediately after the meter.
4. Water meters shall be mounted between 18 inches and 48 inches above the floor. Meters are not permitted above a ceiling or enclosed in a wall.
5. Water meters shall generally be located in the same room where the water service pipe enters the building.
6. The preferred location for a water meter is a mechanical room or basement room, adjacent to the outside wall of the building.
7. A water meter in a finished space may be enclosed in a closet, provided that a door is installed to allow ready access for maintenance and inspection. Adequate meter clearances must be incorporated.

8. Water meters shall not be installed in a location that will be blocked by other equipment, including hot water heaters, water softeners, and other HVAC / plumbing equipment.
9. A generally clear floor area shall be maintained in front of each meter, a minimum of 36 inches out from the center / flow line of the meter. A minimum of 12 inches clearance shall be provided for all other sides of the meter.
10. In special situations where meters are installed in finished building spaces, conduit shall be provided and installed for future routing of the AMR wire to the exterior of the building.
11. For multi-unit buildings AMRs shall be mounted on the exterior wall of the meter room/sprinkler room.
12. Unmetered bypass lines are not permitted.
13. Where a private fire pump serves exterior fire hydrants, full-diameter metering of the fire line is required.
14. Where a fire sprinkler system is not required to be fully metered, the backflow device shall have a detector check bypass meter and shall comply with all City metering and AMI standards.
15. All water meters and AMI communication radios shall be purchased from the City and shall comply with all standard specifications in effect at that time.
16. Meters installed as part of an interconnect between the City of Joliet and a non-City water distribution system shall comply with all current City metering standards.

3.4.5 RPZ Valve Requirements

The following are the City requirements for RPZ valves:

1. RPZ required on domestic water supply to all non-residential buildings.
2. RPZ required on water supply to all fire sprinkler systems.
3. RPZ required on all irrigation systems.
4. Upon a showing of circumstances to warrant same, a double check valve may be substituted for an RPZ device on fire protection systems with the approval of the Director of Public Utilities.
5. Install RPZ a minimum of 12" and a maximum of 5 feet above the finished floor elevation measured from the bottom of the device.
6. Install RPZ a minimum distance of 12" from any building structure or safety devices as measured from the body of the device.
7. Install RPZ a maximum of 5 feet from a floor drain.
8. The RPZ shall be located after (downstream of) the water meter.

3.4.6 Master Metering

Every separate building supplied with City water must have its own separate service connection and meter. A single service line and a Master Meter can be used for two or more buildings located on the same lot or for apartment developments, trailer courts or similar projects covering one lot. In these Master Meter applications where an assured continuous supply must be maintained, the domestic development demand can be split and two meters may be used, each with its own service connection to the City main and then manifolded on the customer side of the meter. Beyond meeting the need to provide an uninterrupted supply to a development, the manifolding of more than 2 meters shall not be allowed.

3.4.7 Connecting to Existing Water Mains

Connection to the end of an existing water main shall be with a valve only. No new water main should be connected to the existing water main unless the new water main can be pressure tested separately. Connection to an existing water main shall be done by pressure connection only when authorized by the Director of Public Utilities. Pressure connection and valve shall be located within the valve vault. No pressure connection shall be within 3' of an existing water main joint. If pressure connection cannot be done, use a cut in sleeve and tee connection. All fittings will be swabbed out with a chlorine solution of at least 50 mg/L. A City Representative must test this solution.

3.4.8 Water Service Connections

Service connections to water mains are not permitted until after bacteriological sampling and analysis has been completed to the satisfaction of the Director of Public Utilities. No water service connection to new water mains shall be made by any person or firm other than a State of Illinois licensed contractor, with a State of Illinois licensed plumber on the job, and bonded with the City. The City of Joliet Water Department shall be responsible for completing all taps to existing water mains. Contractor will be responsible for calling 815-724-4220 to schedule an appointment with the City Department of Public Utilities. Appointments are available on Tuesdays and Thursdays.

3.4.9 Abandoning Existing Services and Mains

Water mains to be abandoned in place shall be cut and capped. In certain instances, the City may require flowable fill to be placed in the abandoned water main.

All existing services shall be abandoned at the corporation stop (close corporation stop, cut services, and install copper disk). Existing services shall not be reused without approval of the City. Disconnection of all services must be performed prior to the demolition of an existing structure.

3.5 FIRE PROTECTION REQUIREMENTS

3.5.1 Fire Protection Supplies

Fire flow requirements will be approved by the Director of Public Utilities.

The required fire flows may be computed at a residual pressure of 25 psi for Fire Department use. It should be recognized that higher residual pressures may be necessary for specific fire protection demands.

The following flow requirements are guidelines which will be modified based upon construction types, size and height of the buildings:

TABLE 1
Fire Flow Requirements

Use	Flow (gpm)
Manufacturing and Storage	3,000 to 5,000
Institutional (Assumed limited hazard, fire resistive construction, or automatic protective devices provided)	3,000 to 4,000
Commercial and Mercantile	3,000 to 5,000
Business and Office (Assumed limited hazard)	2,500 to 3,500
Single Family Detached Residential (1,000 gpm typically used for average home size and spacing)	1,000 to 1,500
Town or Row Houses (1,500 gpm average, additional quantity due to risk of fire to adjoining structures or units)	1,000 to 2,000
Apartments (Low-end requirements for fire resistive structures, higher-end requirements for wood frame, similar construction)	3,000 to 4,000

3.5.2 Public Fire Flow Requirements

Public fire flow requirements (Fire Department pumper supply) and domestic consumption demands are cumulative.

3.5.3 Private Fire Protection Requirements

Private fire protection demands (standpipe systems, sprinkler systems, etc.) will not be considered cumulative with public fire flow demands. These requirements are based upon the building height, area, use, and construction type.

3.5.4 Fire Hydrant Requirements

Fire hydrants shall be located 7.5 feet from the right-of-way within north or west parkways.

All points of buildings shall be within 300 feet of all points of the building, as the hose lays (must be shown on engineering plans).

The linear spacing of hydrants shall not exceed 300 feet.

At least one hydrant, shall be located within 100 feet of the building Fire Department Connection (Siamese), or as otherwise stated by the City Fire Code review official. This hydrant shall not be supplied by a private fire pump.

Fire hydrants outside of public rights-of-way shall be within 10 feet from a paved roadway or other paved access drive. Where necessary to minimize hydrant lead length for water quality, hydrants may be located up to 20 feet from a paved roadway or access drive. Where a curb is present, this shall be measured from the front face of the curb.

Access to hydrants shall be provided by paved roadways (minimum structural number = 2.5) routes adequate in width, clearance and strength to support all fire equipment. Such routes shall be maintained during all seasons of the year.

3.6 WATER SYSTEM VALVE REQUIREMENTS

3.6.1 Valve Boxes and Valve Vaults

Valve boxes may only be used for fire lines that are less than 8 inches in size. The valve box shall be located in a grassy area; otherwise a valve vault must be used.

Valves for water mains or fire lines 8 inches or larger shall be provided with a vault.

All tapping valves 4" and greater must be installed in vaults.

Vaults for valves on the public water main system shall be provided with lids per the approved material list stating "City of Joliet" and "Water". Vaults for valves on the private portion of the water system shall be provided with lids stating "Water".

3.6.2 Valve Locations

Valves shall be located such that no more than a maximum of 500 feet to 700 feet of main may be shut off at any given time. This spacing should be reduced, such that no more than 25 to 30 single-family homes, or 50 multi-family residences (excluding apartment buildings) would be shut off at any given time.

Where a "tee" is installed, at least two (2) valves will be utilized.

Where a "cross" is installed, at least three (3) valves will be utilized.

Critical customers must have redundant valves in order to provide continuous service to the facility if there are system breaks. An appropriate configuration of valves to a critical customer will be reviewed on a case by case basis and approved by the Director of Public Utilities.

3.7 WATER SYSTEM CASING REQUIREMENTS

3.7.1 Water Main Casing Pipes

Manufactured non-metallic or non-corrosive casing spacers, adjustable runners, or cradles shall be used to support the pipe in the casing. A minimum of three supports shall be used per pipe, or per manufacturer’s recommendation. Water main installed within casing pipes shall have restrained joint construction the entire length of the casing pipe for future removal if necessary.

3.7.2 Casing Pipe Material

The steel casing pipe shall be bituminous coated, minimum of 30 mils thickness inside and out, and shall be of leak proof construction, capable of withstanding the anticipated loadings. The steel casing pipe shall have a minimum yield strength of 35,000 psi and shall meet the requirements of ASTM A139, Grade B. Ring deflection shall not exceed 2% of the nominal diameter. The steel casing pipe shall be delivered to the jobsite with beveled ends to facilitate field welding.

TABLE 2

Water System Casing Pipe Material

Steel Casing Diameter	Minimum Wall Thickness (Inches)
20" and 22"	0.344
24"	0.375
28"	0.438
30"	0.469
32"	0.501
34" and 36"	0.532

3.7.3 Sizing of Casing Pipes

The diameter of the casing pipe shall be a minimum of 12 inches greater than the outside nominal diameter of the water main. For pipes greater than 20" the contractor may request a variance from the 12" casing differential as approved by the Public Utilities Director.

3.8 WATER SYSTEM INSPECTION REQUIREMENTS

The mandatory inspection of water main improvements throughout the City of Joliet will be performed to ensure that the project is being constructed in accordance with the approved Final Engineering plans, and to determine if minimum construction and material standards are achieved. If the developer or contractor desires to deviate from the approved plan or does not feel that minimum construction standards are being satisfied, he/she is responsible for contacting the City immediately. The City of Joliet will not accept a substandard product, and will not be responsible for any additional cost incurred by the developer / contractor as a result.

NOTE: Only City of Joliet personnel may operate public water main facilities. The contractor is not permitted to open, close, or adjust any public water valve for any reason. If an emergency situation arises, the contractor shall contact the City of Joliet Public Utilities Department immediately.

3.8.1 Water System Testing Requirements

A representative of the City of Joliet Public Utilities Department shall witness all tests. All tests shall be scheduled 48-hours in advance. The following is a list of tests, which shall be required for water distribution system improvements in the City of Joliet. Water testing procedures can change, so the contractor should discuss the testing process with field staff, prior to construction to see if the requirements are accurate.

1. After a water main has been installed and before the water main has been placed into operation, the contractor shall "bag" or cover fire hydrants. The bag shall not be removed until after the main has become operational. All hydrants shall be placed to face the road.
2. Flushing: Flushing of all water system improvements will be performed to create a minimum pipeline velocity of 2.5'/per second.
3. Leakage Test: All public water main improvements shall pass a leakage test in conformance with AWWA C-600 and C-603. Allowable leakage in gallons per hour may not exceed that determined by the following formula:

$$L = ND \sqrt{P}$$

7400

L = Allowable leakage in gallons per hour
N = Number of joints in length of tested main
D = Nominal inside diameter of pipe in inches

P = Average test pressure in psi

4. Pressure Test: All public water main improvements shall pass a pressure test in conformance with the requirements of ANSI/AWWA C600-87 Section 4, and the Testing requirements shall follow the “Standard Specifications for Water and Sewer Main Construction in Illinois”, latest edition.

The contractor shall, after installation of the water main system or parts thereof, pressure test the new system. A 1-hour pre-test must be made and passed by the Contractor before scheduling the pressure test with the City. The main shall then be pressure tested at 150 PSI for a duration of 2-hours in the presence of a representative of the City of Joliet Public Utilities Department. If a scheduled pressure test does not pass because of the failure of the Contractor to hold a pre-test, the City may charge a re-inspection fee to the Contractor. Any other water main work will be halted until the re inspection fees have been paid.

5. Disinfection: After a successful pressure test, the main shall be chlorinated by gas injection method only, by a qualified technician. All water mains shall pass a disinfection test in conformance with AWWA C65186. The following test criteria shall be met:

- a. 50-ppm initial chlorine concentration (chlorine gas only)
- b. 25-ppm residual chlorine concentration (after 24-hour duration).
- c. Sampling will be performed on two consecutive days, 24-hours apart, Monday through Thursday, 24-hours after chlorination, and after the main has been flushed.

A City representative shall determine the number of samples taken. Sample must be collected by a City of Joliet representative and analyzed by the City’s laboratory. If after four (4) samplings, the results do not yield two (2) consecutive satisfactory readings, a re-chlorination will be necessary. Only the City of Joliet Public Utilities Department shall make the water system operational after receiving satisfactory lab reports.

6. All private fire service lines shall pass a pressure test in conformance with the requirements of ANSI/AWWA C600-87 Section 4. The following test criteria shall be met:

- a. 150 psi minimum initial test pressure.
- b. 150 psi minimum residual pressure after 2-hours.
- c. If an existing valve is utilized for the pressure test, the contractor is responsible for the performance of the valve.

- d. Test to be observed by the City of Joliet representative.
- e. If the pressure gauge fails to 'zero' at the end of the test, the test will be failed.

3.8.2 Water System Inspection Requirements

The following are the required inspections for any new water system enhancement:

1. Notice: The developer or contractor shall contact the City of Joliet Public Utilities Department a minimum of 48-hours in advance of a scheduled inspection.
2. Acceptance Inspection: Prior to City acceptance of a public water main, the City of Joliet Public Utilities Department must inspect and approve the improvement. A punch list of items, which require corrective action, will be generated, and the developer will coordinate resolution efforts and schedule a re-inspection. Following approval, the acceptance process may proceed. Acceptance proceedings will be coordinated through the Joliet Public Utilities Department.
3. Maintenance Inspection: Prior to the release of a maintenance guarantee, the City of Joliet Public Utilities Department must inspect and approve the condition of the water main. This inspection is performed a minimum of one year from the date of City acceptance of the improvements. This will be at the developer's request, or following notification from the financial lending institution that the expiration date for the maintenance letter of credit is approaching. A punch list of items, which require corrective action, will be generated, and the developer will coordinate resolution efforts and schedule a re-inspection. Following approval, the maintenance guarantee will be released. The release of the maintenance guarantee shall be coordinated with the Public Works and Utilities Department.
4. B-Boxes: Upon completion of the project, the B-boxes will be adjusted to grade, and checked to see if they are operational without altering the shutoff key. Locations of the B-box with GPS point and measurements to the property lines shall be supplied to the Public Utilities Department and shown on the as-built plans for the project. The Public Utilities Department will issue a charge for locating B-Boxes. B-box locations shall be stamped on the curb/sidewalk with a "W".

4 SANITARY SYSTEM DESIGN CRITERIA

4.1 GENERAL SANITARY SYSTEM REQUIREMENTS

All sanitary sewage of domestic and other water borne wastes shall be collected and conveyed in a sanitary sewer pipe system to a point of discharge into an existing sanitary sewer system, City of Joliet interceptor, or sewage treatment plant. No sanitary sewage shall be allowed to enter any storm sewer system or discharge onto the ground or into

receiving streams without first being treated in accordance with city, county, state and federal regulations.

4.1.1 Design Approval

The Department of Public Utilities shall approve all designs in accordance with the City Utilities Design Plan. The Department of Public Utilities shall review and comment on all designs. Designs shall conform to Appendix A – Approved Materials List and Appendix B– Standard Details. Any modifications to these standard details require approval from the Director of Public Utilities.

Proposal of new sanitary sewer lift stations requires approval from the Director of Public Utilities, prior to the design and review process. Appendix C – Lift Station Design Requirements provides the requirements for lift stations.

4.1.2 IEPA Permit Required

All public sanitary sewer mains require an IEPA Construction permit number prior to construction. Some private extensions may require a permit, dependent upon the design population equivalent.

4.1.3 Public and Private Sanitary Sewers

The City maintains public sewer mains and the wye or tie-in location of the private service. The maintenance and repair costs for the sanitary sewer system beyond the wye or tie-in location are the responsibility of the property owner or property owner’s association. In such cases where the City performs maintenance or repairs on the private sanitary sewer system, the City reserves the right to charge the property owner for necessary work.

NOTE: All engineering plans shall clearly differentiate between all portions of the public and private sanitary sewers.

4.1.4 New Business Wastewater Survey

All new businesses must complete the Appendix E – Pretreatment Questionnaire. A new business is defined as any new construction of a facility, any business that is modifying an existing space, and any business that is entering a previously unoccupied space. All businesses that will be producing sources of non-domestic wastewater and wish to discharge wastewater to the City of Joliet wastewater treatment plants must comply with:

- The City’s Sewer Use and Pretreatment Ordinance, Prohibited Discharge Limitations (Ordinance Section Sec. 31-281)
- Local Limits (Specific Limits on Discharge) (Ordinance Section 31-284)
- All dischargers are subject to a wastewater surcharge for BOD and TSS (Ordinance Section 31-412)

4.1.5 Wastewater Discharge Permit Determination

Upon review of the Pretreatment Questionnaire, the City will determine if further information is needed, and if an Industrial User Discharge Permit subject to the City's Industrial Pretreatment program under 40 CFR 403 is required. The City will require a meeting with the business of interest to discuss the discharge and begin the discharge application process if needed.

4.2 SANITARY SEWERS REQUIREMENTS

4.2.1 Sanitary Sewer Pipe Materials

All sanitary sewer pipe materials and appurtenances shall be in conformance with Appendix A – Approved Materials List and Appendix B – Standard Details.

4.2.2 Location in the Public Right-Of-Way

Sanitary sewers shall be located within the public right-of-way as directed by the Director of Public Utilities. In general, sanitary sewers shall be located 7.5 feet inside the right-of-way on the south and east sides of the right-of-way.

4.2.3 Curvilinear Alignment of Sanitary Sewers

Curvature of sanitary sewers is allowed for sewers 8 inches to 12 inches in diameter. Alignments must follow the general alignment of streets. Only a simple curve design is acceptable. The radius of curvature will be assessed on a case by case basis and approved as directed by the Director of Public Utilities. Compression type pipe joints are required and manholes are required at the beginning and end of all curves. Maximum joint deflection shall not exceed the manufacturer's recommendations.

4.2.4 Sewer and Water Main Separation

Sanitary sewers and services that are laid in the vicinity of pipelines designated to carry potable water shall meet the conditions set forth in Section 3 of this manual.

4.2.5 Depth of Pipe Cover

All pipe shall be laid to a minimum depth of 6 feet measured from the proposed ground surface to the top of the pipe, unless specifically allowed otherwise in special circumstances by the Director of Public Utilities. All sanitary sewers and services with less than 4 feet of cover shall be insulated with a 2- inch exterior grade rigid insulation board. The insulation shall have a minimum R-value of R-9, and comply with ASTM C 578-92 Type 1X.

4.2.6 Overhead Sewers

The City reserves the right to require overhead sewers dependent upon the depth of the sewer main and the loading.

4.2.7 Sanitary Sewer Sizing

Sewer size shall be designed on the basis of a design average flow of not less than 100 gallons per capita per day and provide a minimum of 2.0 feet per second velocity when flowing full (using a Manning's n-value of 0.013). Sanitary sewers shall be designed to accept all existing and future demand, based on the fully developed state under present zoning and the City of Joliet Comprehensive Plan. The Director of Public Utilities may increase sewer size as required. In no case shall a public sewer be sized less than 8 inches in diameter.

4.2.8 Oversizing and Extra Depth Requirements

The Director of Public Utilities may request that sanitary sewers either be oversized or installed at an additional depth in order to provide service to additional benefiting properties.

4.2.9 Sanitary Sewer Minimum Slopes

Sanitary sewers shall be designed such that the minimum slopes are not less than the following:

TABLE 3
Sanitary Sewer Minimum Slopes

Pipe Diameter	Minimum Slope	Desired Slope
6 inch (service pipe only)	1.00%	1.00%
8 inch	0.40%	0.45%
10 inch	0.28%	0.30%
12 inch	0.23%	0.25%
15 inch	0.15%	0.18%
18 inch	0.12%	0.14%
21 inch	0.10%	0.12%
24 inch	0.08%	0.10%
27 inch	0.067%	0.08%
30 inch	0.058%	0.07%
36 inch	0.046%	0.055%
42 inch	0.036%	0.045%
48 inch	0.031%	0.038%

4.2.10 Sanitary Sewer Maximum Slopes

Sanitary sewers shall be designed such that the slopes do not exceed a maximum of 12%. If the sanitary sewer system cannot be designed without exceeding a slope of 12%, then drop manhole assemblies shall be utilized.

4.2.11 0.10' Drop Across Manholes

Manholes are to have a 0.10 foot drop from upstream pipe to downstream pipe.

4.2.12 Limits of Installation

At a minimum, sewers shall extend across the frontage of the property to the limit of the development, at the developer's cost, such that a connection can be made with minimal disturbance in the future. In some cases, the City may require that the sanitary sewer be installed from one corner to the diagonally opposite corner, at the developer's cost

3.2.11 Pipe Marking Tape

Provide detectable marking tape manufactured for use in underground locations to be installed in open cut trenches buried one to two feet below grade for all materials of sanitary sewers and force mains.

4.3 SANITARY SEWER MANHOLE REQUIREMENTS

Manholes for sanitary sewers shall have a minimum inside diameter based upon the sizing requirements per Section 4.3.2 and shall be constructed of pre-cast concrete units in accordance with ASTM C 478 and Section 32 of the "Standard Specifications for Water and Sewer Main Construction in Illinois," or polymer concrete units as required by the Director of Public Utilities and shall follow the City of Joliet sanitary sewer standards indicated in Appendix A – Approved Materials List and Appendix B– Standard Details.

Manholes on the public sewer system shall be provided with lids per the approved material list stating "CITY OF JOLIET" and "SANITARY". Manholes on the private portion of the sewer system shall be provided with lids stating "Sewer".

4.3.1 Manhole Location and Spacing

Manholes shall be located at the junction of two sanitary sewer pipes or at any change in grade, alignment or size of pipe. The maximum spacing of manholes shall be 400 feet, or as approved by the Director of Public Utilities.

In general, the City of Joliet prefers to minimize the number of manholes needed for a project. This will help reduce future operation and maintenance costs.

4.3.2 Manhole Sizing Requirements

The following table provides minimum manhole sizing requirements. For sewer depths greater than 15', a minimum 5' diameter manhole is required. The table provided is not a substitute for engineering judgement.

TABLE 4

Minimum Manhole Sizing Requirements

Minimum Angles Between Pipes for Specific MH Diameters and Pipe Diameters							
Pipe Diameter	Manhole Diameter						
	48-inch	60-inch	72-inch	84-inch	96-inch	108-inch	120-inch
8-inch	38	30	25	22	19	17	15
10-inch	43	34	28	24	22	19	17
12-inch	48	38	32	27	24	21	19
15-inch	56	45	37	31	28	27	22
18-inch	65	51	42	36	32	28	26
21-inch	91	70	57	49	42	37	33
24-inch	104	78	64	54	47	42	37
27-inch	118	87	70	59	52	46	41
30-inch	137	97	77	65	56	50	45
36-inch	N/A	119	92	77	66	58	52
42-inch	N/A	155	110	89	76	67	59
48-inch	N/A	N/A	131	103	87	76	67
54-inch	N/A	N/A	N/A	119	99	85	75
60-inch	N/A	N/A	N/A	143	113	96	84

* If the diameters of the connecting pipes are not the same diameter the following equation must be true for the manhole diameter selected. Where K is the minimum angle for the pipe diameter of a specific manhole diameter and X is the design angle between the two pipes.

$$X^{\circ} > (K_{\text{pipe1}} + K_{\text{pipe2}})^{\circ} / 2$$

** If there are three pipes connecting to the structure both equations below must be true for the manhole diameter selected. Where K is the minimum angle for the pipe diameter of a specific manhole diameter. X is the design angle between pipe 1 and pipe 2 and Y is the design angle between pipe 1 and pipe 3.

$$X^{\circ} > (K_{\text{pipe1}} + K_{\text{pipe2}})^{\circ} / 2$$

$$(X^{\circ} + ((K_{\text{pipe2}} + K_{\text{pipe3}})^{\circ} / 2)) < Y^{\circ} < (360^{\circ} - ((K_{\text{pipe1}} + K_{\text{pipe2}})^{\circ} / 2))$$

4.3.3 Invert Elevations in Manholes

The connecting outflow pipe of a given structure must have a one tenth of a foot drop in elevation from the lowest inflow pipe invert elevation. All inflow pipes shall have a precast or poured place trough directing the flow towards the out pipe. If the sewer main invert differs by 2-feet or greater an outside drop manhole must be utilized. Service connection

inverts that differ by 2-feet or greater may also require an outside drop, as directed by the Director of Public Utilities.

4.3.4 Drop Manholes

Drop manhole assemblies shall be provided at the junction of sanitary sewers where the difference in grade is in excess of 2 foot. The drop assembly shall follow Joliet Standards with filleted inverts. Drops are to be made outside of the structure unless otherwise approved by the Joliet Department of Public Utilities. The drop pipe invert must be within 2-feet of the outlet pipe invert.

The drop pipe must match the pipe diameter of the incoming sewer if the pipe diameter is 12-inches or less, but must be at least 8-inches in diameter. If the incoming sewer pipe is greater than 12-inches the minimum diameter of the drop is two-thirds the diameter of the incoming sewer pipe. The length of the drop and hydrogen sulfide considerations will be subject to consideration as a function of the request to utilize a drop manhole. The City reserves the right to require hydrogen sulfide resistant coatings in the manholes or to construct the manhole of polymer concrete sections, in cases of concern. See Appendix A – Approved Materials List for hydrogen sulfide resistant coatings or Polymer Concrete Manholes that are required in areas where hydrogen sulfide is a concern. The City may require additional drop manhole design modifications as needed to limit the potential for high velocity/flow bypassing the exterior drop pipe and to prevent premature degradation of the structure due to hydrogen sulfide or hydraulic forces.

4.3.5 Requirement for Inspection Manholes and Clean-Outs

All commercial, office, institutional, industrial, and manufacturing buildings shall have an inspection manhole located outside of the building that will allow the City to observe the discharge from the building into the public sanitary sewer system.

An inspection manhole is required for any multi- family building that has more than six (6) units. Additionally, clean-outs shall be required on multi- family services serving between two (2) and six (6) units.

A clean-out will also be required for any service line over 90 feet in length which does not have an inspection manhole.

4.3.6 Grease/Oil/Sand Trap Manholes

Grease/oil/sand trap manholes, as required by the Illinois Plumbing Code, shall be shown on the engineering plans. Grease interceptors shall be provided for all food service establishments and shall meet requirements of both the Illinois Plumbing Code and Section 31-235 of the City of Joliet Code of Ordinances.

4.3.7 Polymer Manholes

Polymer manholes per ASTM D6783 and ASTM C478 shall be required for force main discharge manholes and other locations as determined by the Director of Public Utilities where hydrogen sulfide corrosion may be of concern. Buoyancy design calculations will be required to be submitted

4.4 SANITARY SEWER CONNECTION REQUIREMENTS

A separate and independent building sewer shall be provided for every building. The service pipe shall not be allowed to cross onto an adjacent property. The minimum diameter of a gravity service connection is 6-inches with a minimum slope of 1%. A full size external clean-out shall be provided at 5' outside the building foundation.

Existing building sewers or portions thereof may be used in connection with new buildings only when they are found on examination and testing by the City to meet City Codes, be structurally sound and not a source of infiltration.

4.4.1 Connecting to existing sewer

When connecting to an existing sewer main, contact the Department of Public Utilities to confirm if the existing sewer main has been rehabilitated with a CIPP liner or if there is an existing tap connection for the property. For connecting to an existing sewer that has not been rehabilitated with a CIPP liner by means other than an existing "Y" or "T" one of the following methods shall be used:

1. Using pipe cutter, neatly and accurately cut out desired length of pipe for insertion of proper fittings. Use "band-seal" couplings or similar couplings, and non-shear rings and clamps to fasten the inserted fittings and hold it firmly in place. Mission couplings shall have the length of boot approximately equal to the pipe diameter. Follow manufacturer's recommendations for the installation. No cut-in connection, made by breaking or cutting a hole in the main and inserting the spigot end of an ordinary sewer pipe shall be permitted.
2. Circular, saw-cut of sewer main with proper tools ("Sewer-tap" machine or similar) and proper installation of Inserta-Tee, in accordance with manufacturer's recommendations. This method shall only be allowed for pipe sizes over 18" in diameter. All components of the installation must be encased in self-compacting low strength material (flowable fill).

When connecting to an existing sewer main that has been rehabilitated with a CIPP liner, a LMT service saddle will be required. The host pipe shall be carefully removed from around the entire circumference of the liner and beyond the saddle length by 2 inches on each side. Cut service opening into liner and adhere saddle.

If there is an existing tap connection for the property, the City of Joliet must review the condition of the connection to the City main. If the City confirms the connection is in good condition, then the connection can be made to the existing tap connection within 1-foot of the main using a non-shear mission coupling.

Connections to existing manholes will only be allowed with approval by the Director of Public Utilities.

4.4.2 Extension of Existing Services

Existing sewer service lines may be extended only when they are found on examination and testing by the City to meet City Codes, be structurally sound and not a source of infiltration. The service line shall be extended at a minimum slope for self-cleaning velocity (1% for 6-inch services).

4.4.3 Disconnection of Existing Services

Disconnection of all services must be performed prior to the demolition of an existing structure. Method and location for service line disconnection will be reviewed on a case by case basis by the Department of Public Utilities. In locations where the City has completed sanitary sewer rehabilitation, disconnection at the sewer main may be required.

The preferred method of disconnection of existing services is trenchless disconnection by means of cured-in-place pipelining (CIPP). A 3-foot resin impregnated flexible felt tube shall be installed and fully cured in the location of the service to be disconnected. The CIPP material, design, and installation must meet standards and requirements of ASTM F-1216 and ASTM F2599. LMK O-ring must be installed at each end of the sectional liner to ensure the product is sealed and no leakage will occur.

An alternative method to trenchless disconnection of services is capping the service with a mechanical wing plug and capping/encasing with non-shrink grout. The plug shall be installed such that the maximum amount of service line is abandoned.

4.5 SANITARY SEWER CASING REQUIREMENTS

4.5.1 Casing Pipes

Manufactured non-metallic or non-corrosive casing spacers, adjustable runners, or cradles shall be used to support the pipe in the casing. A minimum of two supports shall be used per pipe for lengths up to 12.5 feet, and a minimum of three supports shall be used for lengths greater than 12.5 feet, or per manufacturer's recommendation.

4.5.2 Casing Pipe Material

The steel casing pipe shall be bituminous coated, a minimum of 30 mils thickness inside and out, and shall be of leak proof construction, capable of withstanding the anticipated loadings. The steel casing pipe shall have a minimum yield strength of 35,000 psi and shall meet the requirements of ASTM A139, Grade B. Ring deflection shall not exceed 2% of the nominal diameter. The steel casing pipe shall be delivered to the jobsite with beveled ends to facilitate field welding.

TABLE 5

Sanitary Sewer Casing Pipe Material

Steel Casing Diameter	Minimum Wall Thickness (Inches)
20" and 22"	0.344
24"	0.375
28"	0.438
30"	0.469
32"	0.501
36"	0.532

4.5.3 Sizing of Casing Pipes

The diameter of the casing pipe shall be a minimum of 12 inches greater than the outside nominal diameter of the sewer.

4.6 LIFT STATION REQUIREMENTS

4.6.1 Force Main Requirements

Sanitary sewer force main shall conform to the requirements of Appendix A – Approved Materials List. In addition, the following requirements will apply:

1. 4" minimum diameter.
2. Pipe shall be HDPE, DR 11.
3. All force mains shall be installed with a tracer wire.
4. Clean-outs at all vertical and/or horizontal bends, or at 700' minimum intervals in a manhole. Clean-outs will be installed via the use of a "T" connection with a cap at the top of the clean-out.
5. Minimum flow velocity of three (3) fps.
6. Air release valves shall be located at the high points of the force main, every 1,800 feet along flat slopes, and as required by a surge analysis.
7. A surge analysis shall be required at the direction of the Director of Public Utilities.

4.6.2 Facility Requirement

Lift stations will be permitted only where site conditions do not allow for the construction of a functional gravity sewage collection system. Where lift stations are permitted, the following criteria shall be met:

1. Lift station design requirements will conform to Appendix C – Lift Station Design Requirements.
2. A lift station design report shall be submitted for review (Contact the City of Joliet Department of Public Utilities).
3. A complete set of shop drawings and product specification information (i.e.: generator, pump, lift station) shall be provided to the City for review.
4. A detailed plan depicting the proposed layout of the lift station, including the location of the generator, control panel, wet and dry wells, access drive, and fencing, lighting, and landscape features shall be submitted for review.
5. A natural gas powered emergency generator shall be provided.
6. A communication connection to the main Wastewater Treatment Plant alarm system shall be provided. Coordination will be required with Metropolitan Pump (815-886-9200).
7. A dedicated lot (40'x40') and paved 12' access drive shall be provided to the City.
8. A fence shall be provided designed to withstand the wind loading and with aesthetics acceptable to the City.
9. The drive shall allow for access to the wet well for pump removal.
10. All lift stations will be subject to the Planning and Zoning design review.

4.7 SANITARY SEWER INSPECTION REQUIREMENTS

4.7.1 SANITARY INSPECTION PROCEDURES

Inspection of sanitary sewer improvements throughout the City of Joliet will be performed to ensure that the project is being constructed in accordance with the approved Final Engineering plans, and to determine if minimum construction and material standards are achieved. If the developer or contractor desires to deviate from the approved plan or does not feel that minimum construction standards are being satisfied, he/she is responsible for contacting the City immediately. The City of Joliet will not accept a substandard product, and will not be responsible for any additional cost incurred by the developer / contractor as a result. The following tests shall be required for sanitary sewer improvements in the City of Joliet. An authorized representative of the City of Joliet shall supervise all tests. All tests shall be scheduled a minimum of 48 hours in advance.

1. Air Test: All sanitary sewers shall pass an air test in conformance with Section 31 of the “Standard Specifications for Water and Sewer Construction in Illinois”. The sewer shall be tested at an initial pressure of 3.5 psig above the level of the ground

water, and the time for a pressure drop of 1 psi shall be determined. The time for the pressure drop to occur shall not be less than that specified by the “Standard Specifications for Water and Sewer Construction in Illinois”.

2. Pressure Testing: All sanitary force mains will be tested utilizing the “Standard Specifications for Water and Sewer Construction in Illinois” specifications.
3. Vacuum Testing: All sanitary manholes (public and private) shall be tested for leakage by vacuum testing in accordance with ASTM C-1244. One copy of the written inspection reports shall be furnished to the City of Joliet.
4. Deflection Test: All PVC sanitary sewers shall pass a mandrel test in conformance with Section 31 of the “Standard Specifications for Water and Sewer Construction in Illinois”.
5. Televising: The Contractor shall provide the Department of Public Utilities a post construction PACP coded, color video record and a type written transcription of the internal inspection of the newly constructed sewer system. This shall be submitted prior to final approval and acceptance of the system. Video inspection must be coded by a PACP certified technician. All public and private lines equal to and larger than 8” in diameter shall be televised. All cleaning or televising operations must be coordinated prior to the commencement of the work with the Department of Public Utilities. The sewer pipe must be televised with 95% or more of the sanitary pipe visible. Any cleaning operations must be accompanied with a vactor at the downstream manhole to ensure no debris passes downstream. The contractor must rotate the lens of the camera to look at all services. All service connections, defects, and observations must be coded in the television report. When the proposed sanitary sewer system is to connect to an existing sanitary sewer system abutting the property, the existing sewer must also be televised and reported. The contractor shall coordinate the televising of existing contiguous sewers with the Director of Public Utilities. Costs associated with this work shall be borne by the contractor. Video inspection and database shall be fully compatible with PACP V 7.0.2 format with all header information filled out. Each video inspection shall be labeled with USMH-DSMH. The contractor must submit the PDF reports, video inspection, and Microsoft Access V07 database (all data files and tables shall be linked to the pipe segment ID number) to the City of Joliet.
6. Acceptance Inspection: Prior to City acceptance of public sewers, the City of Joliet Public Utilities Department must inspect and approve the improvement. A punch list of items that require corrective action will be generated, and the developer will coordinate resolution efforts and schedule a re-inspection. Following approval, the acceptance process may proceed. Acceptance inspections will be coordinated through the Department of Public Utilities.

7. Maintenance Inspection: Prior to the release of a maintenance guarantee, the City of Joliet Department of Public Utilities will re-inspect and approve the condition of the sewer improvement. This inspection is performed after a minimum of one year, at the developer's request, or following notification from the financial lending institution that the expiration date for the maintenance letter of credit is approaching. A punch list of items that require corrective action will be generated, and the developer will coordinate resolution efforts and schedule a re-inspection. Following approval, the maintenance guarantee will be released. The release of the maintenance guarantee shall be coordinated with the Public Works and Utilities Department.

4.8 FENCING REQUIREMENTS

This section applies to security and visual screening fencing requirements for lift stations, water treatment facilities, and other Public Utilities Department facilities as applicable.

4.8.1 Required Fence Locations

Fences shall be provided for sanitary sewer lift stations, water treatment facilities, and other facilities indicated by the project specifications and/or development review process.

4.8.2 Design and Approval Procedure

The following sequence shall be followed when a fence is required.

- Developer submits site plan with proposed fence locations.
- Developer to discuss options for material, architectural design, and color with City.
- City approves fence location plan and material, architectural design, and color.
- Developer submits detailed fence design, including structural detail drawings and wind load calculations.
- City approves fence design, generally coordinated with site plan approval timing.

4.8.3 Visual Screening Requirements

Fences shall generally be designed with privacy screening except those located in an industrial or other area with limited view from the public. Due to lighting and security concerns, an open design (e.g. chain link) may be required for some sites. The Department shall determine specific screening requirements for each site.

4.8.4 Dimensions

Fence height shall generally be eight feet but may be adjusted by the Department to meet local conditions. The gap between the bottom of the fence and the ground shall be sufficient to allow drainage but generally shall not exceed two inches.





4.8.5 Structural Design

Fences shall incorporate standards in the Fence Design Standards Table, and shall be designed in accordance with City standard details, as amended from time to time. The City may consider alternate designs on a case-by-case basis. All fences shall be designed to withstand a minimum wind load of 115 mph. Drawings shall be provided sealed by a structural engineer licensed in the state of Illinois. Gates and locking hardware shall be provided where indicated by the City.

4.8.6 Architectural Design, Colors, Materials

Fence architectural design, including materials and colors, will be evaluated on a site-specific basis and shall take into account surrounding buildings and landscaping. Impact on lighting inside and outside the fenced area shall also be taken into account. Refer also to the Fence Design Standards Table

TABLE 6
Fence Design Standards

Fence Type	Construction Type	% Visual Opening	Typical Height	Post Construction	Grade Base	Security Feature	Finish / Color	Notes	Example
General Industrial / Commercial	Black metallic chain link	~90%	8 feet	Steel or aluminum	N/A	3 strands barbed wire where	Black		
Enhanced Industrial / Commercial I Fence	Steel or aluminum "wrought iron" style (black).	~90%	8 feet	Steel or aluminum	N/A	Angled integrated spikes	Black		
Aluminum Privacy		~0 to 10%	8 feet		N/A		black or matching environment		
Wooden Privacy	"Shadowbox" (alternating board) cedar	0% at right angle	8 feet	Wood with steel reinforcement	N/A		sealed natural cedar or stained to match		
Vinyl Privacy			8 feet	Vinyl with steel reinforcement	Square steel tube anchored to concrete foundation			Bottom horizontal support rail needs weep holes and steel reinforcement.	

5 DESIGN REFERENCES

5.1 DESIGN REFERENCES

All work shall be designed and constructed in accordance with the following references as they apply:

1. "Standard Specifications for Road and Bridge Construction," Illinois Department of Transportation, latest edition.
2. "Manual for Structural Design of Portland Cement Concrete Pavement," Illinois Department of Transportation, latest edition.
3. "Manual of Instructions for the Structural Design of Flexible Pavements on Projects involving MFT, FAS, and FAUS Funds," Illinois Department of Transportation, latest edition.
4. "Design Manual," Illinois Department of Transportation, latest edition.
5. Standard Specifications for Water and Sewer Main Construction in Illinois, latest edition.
6. Will County "Storm Water Ordinance" as adopted by the City of Joliet.
7. Federal Highway Administration "Manual on Uniform Traffic Control Devices, for Streets and Highways", latest edition.
8. American Association of State Highway and Transportation Officials "A Policy on Geometric Design of Highways and Streets", latest edition.

APPENDIX A

Approved Materials

List

City of Joliet Department of Public Utilities Approved Materials List



Water System

1. Ductile Iron Pipe

- A. Ductile iron pipe complying with AWWA C151/ANSI A21.51, thickness Class 52, with joints complying with AWWA C111/ANSI A21.11. Use cement lining complying with AWWA C104/ANSI A21.4, standard thickness. Provide exterior zinc coating in accordance with ISO 8179-1.
- B. Restrained joint system shall be Meg-A-Lug.
- C. Serrated silicon bronze wedges, two per joint for pipes 12 inches or smaller, four per joint for pipe for pipes larger than 12 inches.
- D. Polyethylene encasement meeting AWWA C105 with three layers of co-extruded linear low density polyethylene film fused into one with the inside surface infused with a blend of anti-microbial additive to mitigate microbiologically influenced corrosion and a volatile corrosion inhibitor to control galvanic corrosion.
 1. In the event that polywrap is observed to not be properly installed on ductile iron pipe, the contractor will be required to take photos of all installed ductile iron pipe to verify that polywrap is properly installed. Photos shall be provided (within "ESRI Field Apps" application) as outlined in the GIS section of the Design Manual.

2. PVC Pipe

- A. PVC conforming to AWWA C900 with rubber-ring gasket bell end or plain end with elastomeric gasket coupling, cast iron equivalent outside diameter, material cell classification 12454 per ASTM D1784. Class 235 pressure pipe with standard dimension ratio of 18.
- B. Use push-on bell and spigot type joints with elastomeric ring configuration to ASTM F-477.
- C. Size range is 4 through 12 inches. Water main 16 inches and larger to be ductile iron pipe.
- D. PVC is not for use near gas stations or other sites which may have hydrocarbon contamination. Environmental Site Assessments completed by a certified environmental independent consultant may be required in areas of questionable soil characteristics. The Director of Public Utilities shall have the final determination on allowing the use of PVC C900 DR 18 for potable water mains.
- E. All potable water pipe and fittings installed shall be color coded as required by FAC Rule 62-555.320(21)(b)3, using blue as a predominant color to differentiate drinking water from reclaimed or other water. Underground plastic pipe shall be solid-wall blue pipe, shall have a co-extruded blue external skin.
- F. All PVC pipe used shall be of new or manufactured within the last 2 years. Pipe with surface discoloration will not be allowed.
- G. All fire hydrant leads shall be ductile iron wrapped in polywrap meeting the requirements of 1.D.

3. PVC Restrained Joint Pipe

- A. Mechanical joint retainer gland systems that provide locking segments shaped to pipe barrel that do not create stress points on pipe barrel.
- B. Acceptable products for pipes:
 - 1. a. Meg-A-Lug System.
 - a. Series 2000PV Megalug for MJ to Pipe (C900).
 - b. Series 1500 Megalug Harness for push on joint (C900).
 - c. As recommended by manufacturer for connection to existing pipes and approved by the City

4. Fittings

- C. Provide mechanical joints complying with AWWA C110/ANSI A21.10 or AWWA C153/A21.53.
 - 1. Cement lining: Comply with AWWA C104/ANSI A-21.4, standard thickness.
 - 2. Bolts and nuts:
 - a. Use A-304 stainless steel bolts with nuts and washers of series 300 stainless steel per ASTM A194.
 - b. Sac Nuts: Duratron Sac Nuts or approved equal.
 - i. One sac nut per fitting.
 - 3. Mechanical joint restraint shall be Meg-A-Lug System.
 - 4. No concrete thrust blocks are allowed, except as directed by City Engineer.

5. Gate Valves (14" Diameter and Less)

- A. Design in accordance with AWWA C509 (cast iron body), or AWWA C515 (ductile iron body), bronze fitted, resilient wedge and seat type with non-rising stem and O-ring packing with 2" square operating nut.
- B. Use A-304 stainless steel bolts with nuts and washers of series 300 stainless steel per ASTM A194.
- C. All internal and external surfaces shall have a fusion bonded epoxy coating.
- D. Acceptable valve manufacturers:
 - 1. American Flow Control.
 - 2. Clow.
 - 3. EJ.

6. Butterfly Valves (16" Diameter and Greater)

- A. Design in accordance with AWWA C504 for pressure Class 150B, cast iron body, rubber-seated, tight closing type suitable for buried service. Provide worm gear operator with 2" square operating nut.
- B. Use A-304 stainless steel bolts with nuts and washers of series 300 stainless steel per ASTM A194.
- C. Acceptable valve manufacturers:
 - 1. American Flow Control.
 - 2. Clow.
 - 3. EJ.

7. Insertion Valves

- A. Design in accordance with AWWA C515 epoxy coated split body, resilient wedge or seat type with O-ring seal stuffing, rated for 250 psi working pressure.
- B. Acceptable valve manufacturers:
 - 1. Hydra-Stop Insta-Valve IVP 250.
 - 2. Advanced Valve Technologies EZ2 Valve.

8. Valve Vaults

- A. Provide 4' diameter vaults for valves 10" and less. Provide 5' diameter vaults for valves 12" and larger.
- B. Provide pre-cast concrete structure with EJ 1050Z1 or Neenah R1710 frame.
- C. "WATER" and "CITY OF JOLIET" shall be cast into the lid.
- D. Install Henry Company, RN103- RAM-NEK Preformed Flexible Gasket (Coils) or ConSeal Concrete Sealants, Inc., Type CS-102 at all joints.
- E. Valve vaults shall be concentric for gate valves and eccentric for butterfly valves.
- F. Flexible pipe connectors:
 - 1. Provide flexible rubber gasket collar for connecting pipe to the manhole. Comply with ASTM C923. For pipe 24-inch and smaller, use PSX gasket system by Press-Seal Gasket Corporation, or equal. For pipe 27-inch and larger, use resilient gasket by A-LOK Products, Inc., or equal.
- G.

9. Valve Boxes

- A. American made adjustable valve boxes with "WATER" cast into lid.
- B. Provide stainless steel extension stems for water mains deeper than 6'.
- C. Acceptable Manufacturers:
 - 1. EJ Series 8550
 - 2. Tyler 6850 Series
- D. Valve box stabilizer:
 - 1. Alberico.
 - 2. American.
 - 3. Adaptor, Inc.
 - 4. Or equal.

10. Fire Hydrants

- A. Design in accordance with AWWA C502 (Dry Barrel)
- B. Provide compression type with a 5¼-inch minimum size main valve assembly, O-ring seals, two 2½-inch hose nozzles, and a 4½-inch pumper nozzle with National Standard threads, a National Standard operating nut, and an above ground break flange.
- C. Color for hydrants on potable distribution mains shall be red, hydrants on raw water mains shall be green. Color for private system hydrants shall be yellow.
- D. Maximum spacing for fire hydrants shall be 300 feet.
- E. Acceptable manufacturers:
 - 1. EJ 5BR250.
 - 2. Clow Medallion.
 - 3. Mueller Centurion A423

- F. Provide red color above ground access for tracer wire systems (for PVC water mains only).
 - 1. Acceptable manufacturers:
 - a. Copperhead Industries Cobra Hydrant Flange Package Part #T1-FLPKG
 - b. Or approved equal

11. Tapping Sleeve

- A. Use two-piece bolted sleeve ductile iron or stainless steel type with mechanical joints. Provide joint accessories.
- B. The City of Joliet Water Department shall be responsible for completing all taps to existing water mains. Contractor will be responsible for calling 815-724-4220 to schedule an appointment with the City Water Department. Appointments are available on Tuesdays and Thursdays.
- C. Acceptable manufacturers:
 - 1. Clow F5205
 - 2. Smith Blair 665
 - 3. Cascade CST-EX
 - 4. Or approved equal.

12. Water Service

- A. Service size 2" or less shall be Type "K" copper, installed as one continuous piece from main to curb stop. Service size 4" and larger shall be ductile iron.
- B. Service saddle required for services larger than 1" on ductile iron: Mueller DR2A.
- C. Service saddle required for all PVC connections: Mueller DR2A.
- D. Taps on PVC water main shall be no closer than 2 feet.
- E. Corporation stop: A.Y. McDonald 74701 BQ.
- F. Curb stop: A.Y. McDonald 76104Q.
- G. Service box: Tyler 6500 with BBAF valve box stabilizer.

13. Underground Location for PVC Water Main

- A. Wire: Single Strand, single conductor, copper-clad steel, No. 12 AWG high strength, high carbon with min. 450 lb. break load, min. 30 mil. HDPE insulation thickness (1230B-HS) for direct bury installation; color coded per APWA Standards.
 - 1. Acceptable manufacturers:
 - a. Copperhead Complete Utility Locating System
 - b. Or approved equal.
 - 2.
- B. Connectors:
 - 1. Single use locking three-way locking connectors, Copperhead LSC1230C or approved equal
 - 2. Mainline to service connectors to include dielectric silicon sealant, Copperhead 3WB-01 or approved equal
- C. Provide 1.5 pound magnesium grounding anodes and 12-AWG wire.

- D. Tracer wire test station: Provide for a direct connection to the tracer wire by utility locate transmitter manufactured for the application location; Identified with (green color coded cap or "WATER" on the cap and color coded) per APWA Standards; Two terminal tracer wires to include a manually interruptible conductive/connective link between the terminal for the tracer wire connection and the terminal for the ground rod wire connection; External direct connection points to both tracer wire and ground rod on top of lid; Encapsulated magnet molded into the top portion of the box for detection by ferrous metal locator; Anti-corrosion wax/gel to protect wires.
1. Acceptable manufacturers:
 - a. Copperhead SnakePit Lite Duty XL or Concrete/Driveway Access Point.
 - b. Or approved equal
14. Pipe marking tape:
- A. Provide tape labeled with message that indicates what type of pipe is below, such as "Caution –Buried Water Line Below".
1. Materials (Detectable):
 - a. Provide solid color, organic virgin polyethylene film with a 0.00035" solid aluminum foil core, with clear film reverse printed and laminated to aluminum foil.
 - b. Thickness: 5.0 mil. ASTM D2103
 - c. Tensile strength:15,000 psi ASTM D882
 - d. Elongation:80% ASTM D882-75B
 - e. Adhesives:AV1257/CA1001
 - f. Colors: APWA code for sewer and water
 - g. Printability:45 Dynes ASTM D2578
 - h. Width:6.0 inches
 2. Acceptable manufacturers:
 - a. Pro-Line Safety Products by Pro-Line Safety Product Company
 - b. Or approved equal.

Sanitary Sewer System

1. Gravity Sewer
 - A. For sewers less than 24-inch diameter and for depths up to 18 feet, provide SDR 26 PVC sewer pipe :
 1. 4-inch through 15-inch: Comply with ASTM D3034, SDR 26. Use elastomeric gasket type (ASTM F477 and ASTM D3212). Gaskets for fittings and joints: provide minimum cross-sectional area of 0.20 square inches (ASTM F477).
 2. 18-inch through 24-inch: Comply with ASTM F679, PS-115. Use integral bell gasketed type joints with elastomeric gaskets (ASTM F477 or ASTM D3212).
 3. Branch fittings: factory fabricated type with attached main line coupling. SDR 26.
 4. Risers and service pipe and fittings: SDR 26, solid wall type (ASTM D3034).
 - B. For sewers less than 24-inch diameter and for depths greater than 18 feet and less than 25 feet, provide SDR 21 PVC sewer pipe:

1. Comply with ASTM D2241, SDR 21.
 2. Use push-on bell and spigot type, or Certa-Lok spline-lock system, with rubber ring seal gasket (ASTM D3139).
 3. Branch fittings: Factory fabricated type with attached main line coupling, with same rating as pipe.
 4. Risers and service pipe and fittings: ASTM D2241, SDR 21.
- C. For sewers less than 24-inch diameter and for depths from 25 to 30 feet, provide C900 PVC DR 18 PVC pipe:
1. Use push-on bell and spigot type, or Certa-Lok spline-lock system, with rubber ring seal gasket (ASTM D3139).
 2. Branch fittings: Factory fabricated type with attached main line coupling, with same rating as pipe.
 3. Risers and service pipe and fittings: C900 DR 18 PVC until depth of 18 feet, then SDR 26 PVC Sewer pipe.
- D. For sewers greater than 24-inch diameter, use reinforced concrete pipe (RCP):
1. Comply with ASTM C76, Class V.
 2. Use rubber gasket with steel bell and spigots (ASTM C361 and AWWA 302); HK Hamilton Kent of Canada Limited or equal.
 3. No lifting holes allowed in pipe.
- E. Fiberglass reinforced polyester pipe (FRP) and centrifugally cut fiberglass reinforced polymer mortar pipe (CCFRPM):
1. Only to be used with City approval for large diameter sewers.
 2. Materials:
 - a. Resin system: polyester.
 - b. Glass reinforcement: Grade E-glass filaments.
 - c. Sand: 98 percent silica with maximum moisture content of 0.20 percent.
 3. Manufacture:
 - a. Comply with ASTM D3262.
 - b. Thickness: Comply with manufacturer's recommendations.
 - c. Stiffness: Minimum 46 psi when tested in accordance with ASTM D2412.
 4. Joints:
 - a. Fiberglass sleeve couplings.
 - b. Bell and spigot.
 - c. Elastomeric gaskets complying with ASTM F477. Joints complying with ASTM D4161.
 - d. Acceptable manufacturers: Hobas Pipe USA, Inc., no substitutions.
- F. For water main crossings, provide pressure rated PVC pipe:
1. PVC pressure pipe: Use Type I, Grade 1, PVC complying with ASTM D1784. Comply with ASTM D2241 for 160 psi pressure rated pipe, SDR 26. Use push-on bell and spigot type, or Certa-Lok spline-lock system, with rubber ring seal gasket (ASTM D3139).
 - a. Branch fittings: Factory fabricated type with attached main line coupling, with same rating as pipe.
 - b. Risers and service pipe and fittings: ASTM D2241, 160 psi pressure pipe, SDR 26.
 - c. Adapters: use adapters specifically made for purpose of changing from PVC pressure to PVC gravity pipe. Harco or approved equal.

- G. Couplings:
 - 1. Provide flexible rubber couplings with adjustable stainless steel bands and shear ring complying with ASTM C425 or ASTM C1173 for connecting new pipe to existing sewer pipe and for repairing sewer pipe.
 - a. Acceptable Manufacturer: Mission Rubber Company, LLC.

2. Force Mains:

- A. High density polyethylene extruded pipe (HDPE):
 - 1. Comply with ASTM F714 for sewer pipe, Type III, Class C, Category 5, P34 material as per ASTM D3350.
 - 2. Minimum cell classification 345464C.
 - 3. Minimum thickness DR 11.
 - 4. Black or green striped pipe.
 - 5. Pipe joining: use only personnel certified by pipe manufacturer as thermal butt-fusion technicians. Provide equipment and procedures in strict accordance with manufacturer's recommendations.
- B. Provide tracer wire with marker post a minimum of every 500 feet along force main route at the nearest right-of-way line.
 - 1. Tracer wire shall be cable manufactured specifically for utility location/electronic tracing consisting of a composite of a copper conductor; corrosion resistant jackets/coverings; internal wrappings with synthetic materials; and an outer plastic jacket. Tracer wire shall be NEPTCO Tracesafe, or equal.
 - 2. Marker post shall be Nordic Fiberglass, Inc. Warren MN, Model Number P-50-MG-P-52, or equal.
 - a. Label shall read "UNDERGROUND BURIED SANITARY FORCE MAIN IN AREA – CITY OF JOLIET".
- C. Air release/vacuum valves:
 - 1. Provide stainless steel body and cover, stainless steel float, stainless steel seat or Buna-N needles, and integral flanged inlet sized as shown on the Drawings.
 - a. Include back-flushing hose, ½-inch shut-off valve, 1-inch blow-off valve, and quick disconnect couplings.
 - b. All bolts, valves, fittings and piping to be stainless steel.
 - 2. Acceptable products:
 - a. APCO Series ASU
 - b. ARI Model D-020 metal/metal
 - c. Or equal.
- D. Force main discharge manhole:
 - 1. Provide polymer concrete manhole sections, monolithic base sections and related components complying to ASTM C478.
 - 2. Acceptable manufacturer:
 - a. U.S. Composite Pipe

3. Manholes:

- A. Provide pre-cast concrete structure conforming to ASTM C478 with EJ 1050Z1 frame.
 - 1. "SANITARY" and "CITY OF JOLIET" shall be cast into the lid.
- B. Pipe connections: Flexible synthetic rubber boots meeting ASTM C-923
- C. Manhole diameter shall be determined by sewer outside diameter, relative angles of sewers to each other, the size of holes cored for flexible pipe "boot" connector and a minimum of 8" between cored/cast holes. Refer to Design Manual for manhole sizing.
- D. External frame seal on all new manholes shall conform to conform to ASTM C923: Infi-Shield Uni-Band or WrapidSeal CANUSA.
- E. Manhole exterior joint protection: MacWrap
- F. Manhole exterior surface treatment: Con-Seal CS-55.
- G. Manhole interior protection system where indicated: Sherwin Williams DuraPlate 6100 or Raven 405.
- H. Grade rings: Precast Concrete
 - 1. Maximum of two rings
 - 2. Total height shall not exceed 12"
 - 3. For manholes installed in pavement, one rubber composite adjustment ring shall be provided: EJ Infra-riser or approved equal

4. Sewer System Rehabilitation

- A. Cured-In-Place-Pipelining: Insituform, Inliner USA, National Liner or an approved equal.
 - 1. Design shall comply with ASTM F-1216.
 - 2. End Seal: "Insignia" as manufactured by LMK or equivalent
- B. For CIPP installations greater than 24-inch diameter, temperature sensor cable with a minimum reading of every 5' shall be used to ensure proper curing.
- C. Manhole Patching Material: Strong Seal QSR; Quadex Hyperform; or pre-approved equal.
- D. Cementitious Manhole Sealing: Strong Seal High Performance Mix; or approved equal.
- E. Visible Infiltration: Strong-Plug; Quadex Quad-Plug; or approved equal.
- F. Internal chimney frame seal allowed only on existing manholes as indicated on plans: Raven 581 or SSI Flex-Seal
- G. Couplings for CIPP and Service Connections to CIPP:
 - 1. Provide flexible rubber couplings with adjustable stainless steel bands and shear ring complying with ASTM C425 or ASTM C1173 for connecting new pipe to cured-in-place sewer pipe and for repairing cured-in-place sewer pipe.
 - a. Acceptable Manufacturer: Mission Rubber Company, LLC (Distributed by LMK Technologies, LLC.)
 - 2. LMT Service saddle required for connecting new sewer service connections to mainline cured-in-place sewer pipe. (Distributed by LMK Technologies, LLC.)

APPENDIX B

Standard Details

General Standard Details:

1. GEN-01 CASING
2. GEN-02 INLET PROTECTION FILTER
3. GEN-03 OPEN CUT PIPE INSTALLATION - UNSUITABLE MATERIAL
4. GEN-04 TYPICAL TRENCH DETAIL – PAVEMENT AREA WITH TRENCH AGG. BASE
5. GEN-05 TYPICAL TRENCH DETAIL – NON PAVED AREAS

Pavement Details:

1. PVT-01 DRIVEWAY PAVEMENT
2. PVT-02 TYPICAL PAVEMENT SECTION

Sanitary Sewer System Details

1. SAN-01 SANITARY MANHOLE
2. SAN-02 SANITARY SEWER SERVICE
3. SAN-03 SANITARY SEWER SERVICE RELOCATION
4. SAN-04 EXTERIOR DROP MANHOLE
5. SAN-05 FORCE MAIN MARKER POST
6. SAN-06 AIR RELEASE/VACUUM VALVE AND VAULT
7. SAN-07 FLUME SIZING
8. SAN-08 PLAMER BOWLUS FLUME INSTALLATION
9. SAN-09 TRAPEZOIDAL FLUME INSTALLATION
10. SAN-10 WASTE WATER MAG METER INSTALLATION
11. SAN-11 INODE TELEMTRY FOR PERMANENT MONITORING SITES
12. SAN-12 SANITARY POLYMER MANHOLE DETAIL
13. SAN-13 SANITARY SERVICE CLEANOUT DETAIL
14. SAN-14 CONNECTING SEWER PIPES OF DISSIMILIAR MATERIAL
15. SAN-15 STRUCTURE ABANDONMENT
16. SAN-16 ABANDONMENT OF SEWERS
17. SAN-17 NEW SANITARY MANHOLE ON EXISTING SANITARY MAIN
18. SAN-18 PLUG PIPE
19. SAN-19 FRAME AND COVER CASTING
20. SAN-20 DOGHOUSE MANHOLE
21. SAN-21 ABANDON SERVICE CONNECTION – TRENCHLESS & NON-TRENCHLESS
22. SAN-22 CORE AND CONNECTION TO EXISTING MANHOLE

Water System Distribution Details

1. WTR-01 WATER VALVE VAULT
2. WTR-02 WATER VALVE BOX
3. WTR-03 FIRE HYDRANT
4. WTR-04 PIPE INSULATION
5. WTR-05 WATER MAIN RELOCATION
6. WTR-06 WATER SERVICE CONNECTION
7. WTR-07 PRESSURE CONNECTION
8. WTR-08 WATER METER DETAIL 5/8" X 3/4"
9. WTR-09 POLYWRAPPED DUCTILE IRON RJT LENGTH TABLE
10. WTR-10 PVC RJT LENGTH TABLE
11. WTR-11 LINED WATER MAIN PRESSURE CONNECTION
12. WTR-12 WATER MAIN TERMINATION
13. WTR-13 WATER SERVICE ABANDONMENT COPPER PIPE
14. WTR-14 WATER SERVICE ABANDONMENT DUCTILE IRON PIPE
15. WTR-15 EMERGENCY INTERCONNECT

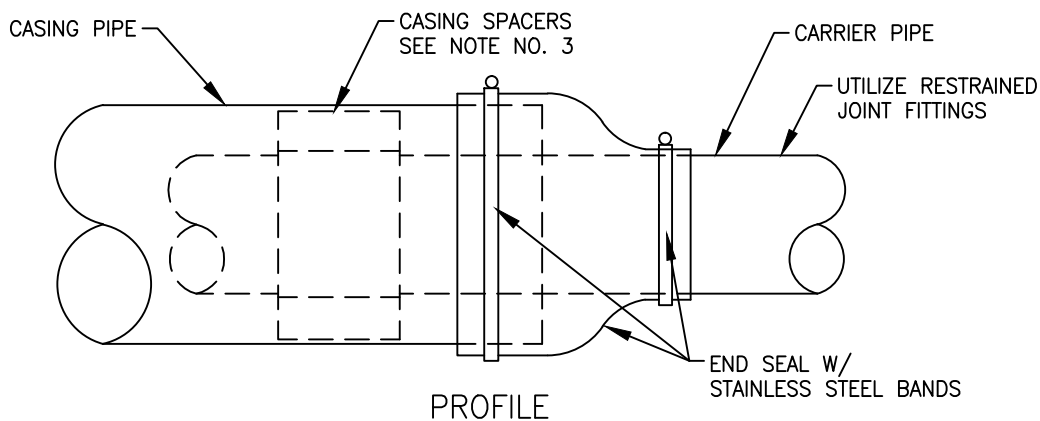
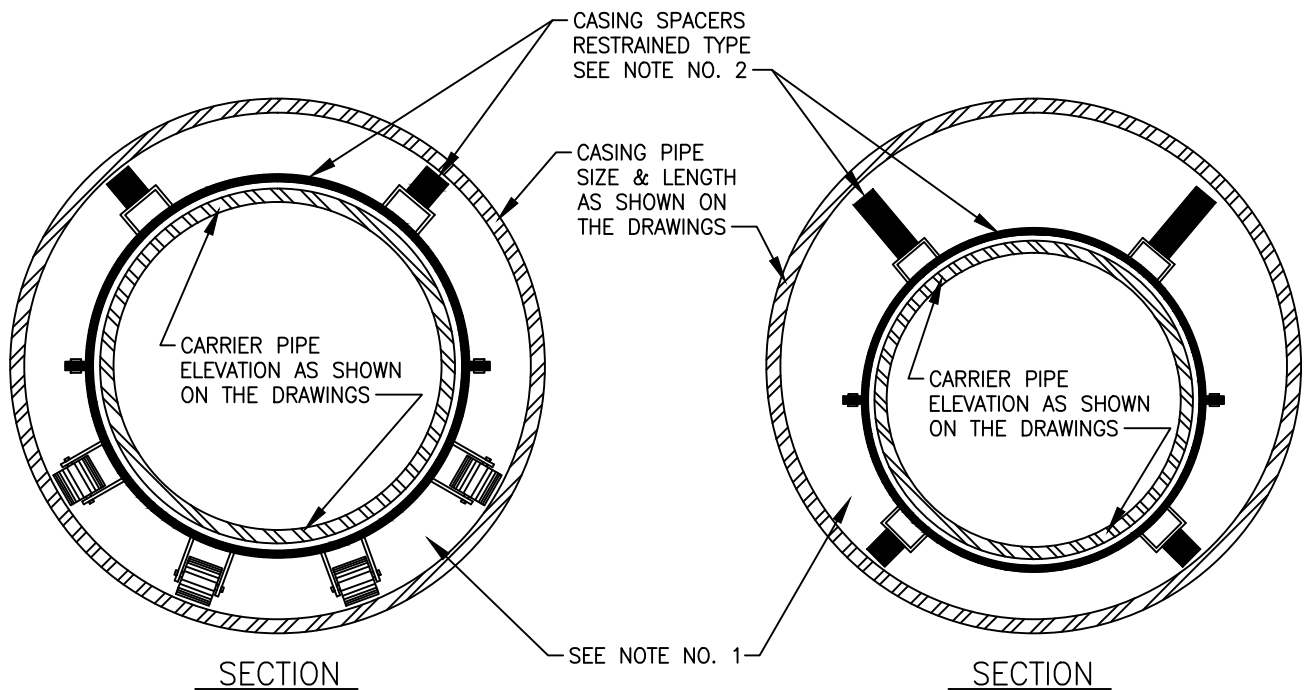

NOTES

1. FILLING OF ANNULAR SPACE BETWEEN CARRIER PIPE AND CASING PIPE WITH SAND OR PEA GRAVEL IS NOT REQUIRED WHEN UTILIZING CASING SPACERS, UNLESS CONTRACTOR IS INSTRUCTED TO DO SO ON DRAWINGS OR IN SPECIFICATIONS.
2. WHERE CARRIER PIPE IS NOT CENTERED IN CASING PIPE, PROVIDE CASING SPACERS WITH LEGS THAT EXTEND TO WITHIN 1-INCH OF CASING INSIDE DIAMETER ON ALL SIDES.
3. PROVIDE NUMBER OF SPACERS AS INSTRUCTED BY SPACER MANUFACTURER, WITH A MINIMUM OF ONE SPACER ON EACH SIDE OF A PIPE JOINT, AND ONE SPACER BETWEEN JOINTS. (THREE (MIN.) PER PIPE LENGTH)
4. ALL CARRIER PIPE INSTALLED WITHIN CASING PIPE TO BE RESTRAINED JOINT TYPE.

NOT TO SCALE

CITY OF JOLIET, ILLINOIS

CASING DETAIL
GEN-01

DATE: MARCH 2019

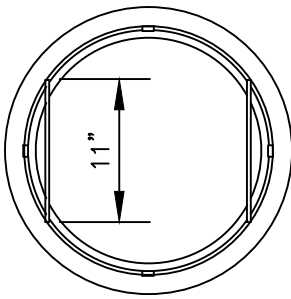
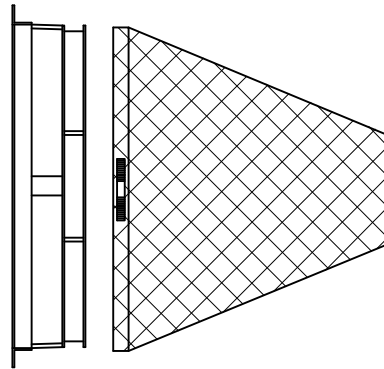
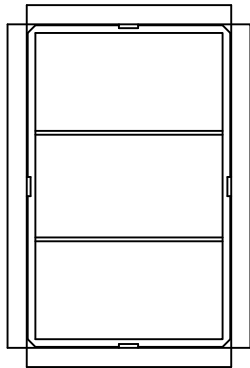

PLAN

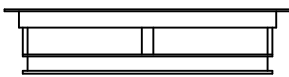
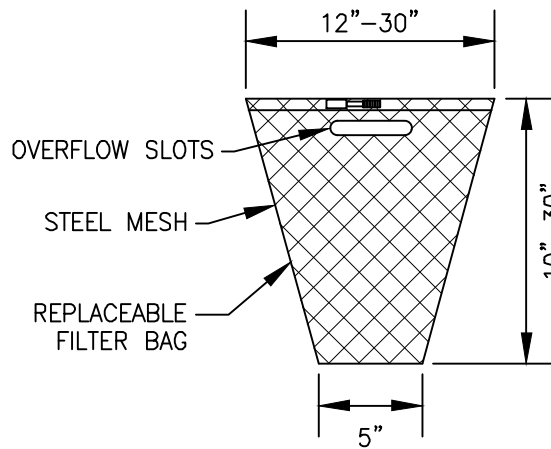

SECTION

GENERAL NOTES:

FRAME: TOP RING CONSTRUCTED FROM 1 1/4" x 1 1/4" x 1/8" ANGLE.
 BASE RING CONSTRUCTED OF 1 1/2" x 1/2" x 1/8" CHANNEL.
 HANDLES & SUSPENSION BRACKETS CONSTRUCTED FROM 1/4" x 1 1/4" FLAT. ALL STEEL CONFORMING TO ASTM-A36.

REPLACEABLE BAG: CONSTRUCTED FROM 4 OZ./SQ. YD. NON-WOVEN POLYPROPYLENE GEOTEXTILE REINFORCED WITH POLYESTER MESH. CONNECTED TO BASE RING WITH STAINLESS STEEL STRAP & LOCK.

STEEL MESH: REMOVABLE STAINLESS STEEL MESH STRAINER BASKET. 1/4" DIA. HOLE SIZE, 58% OPEN AREA.

NOT TO SCALE

CITY OF JOLIET, ILLINOIS

INLET PROTECTION
 FILTER DETAIL
 GEN-02

DATE: OCT. 2017

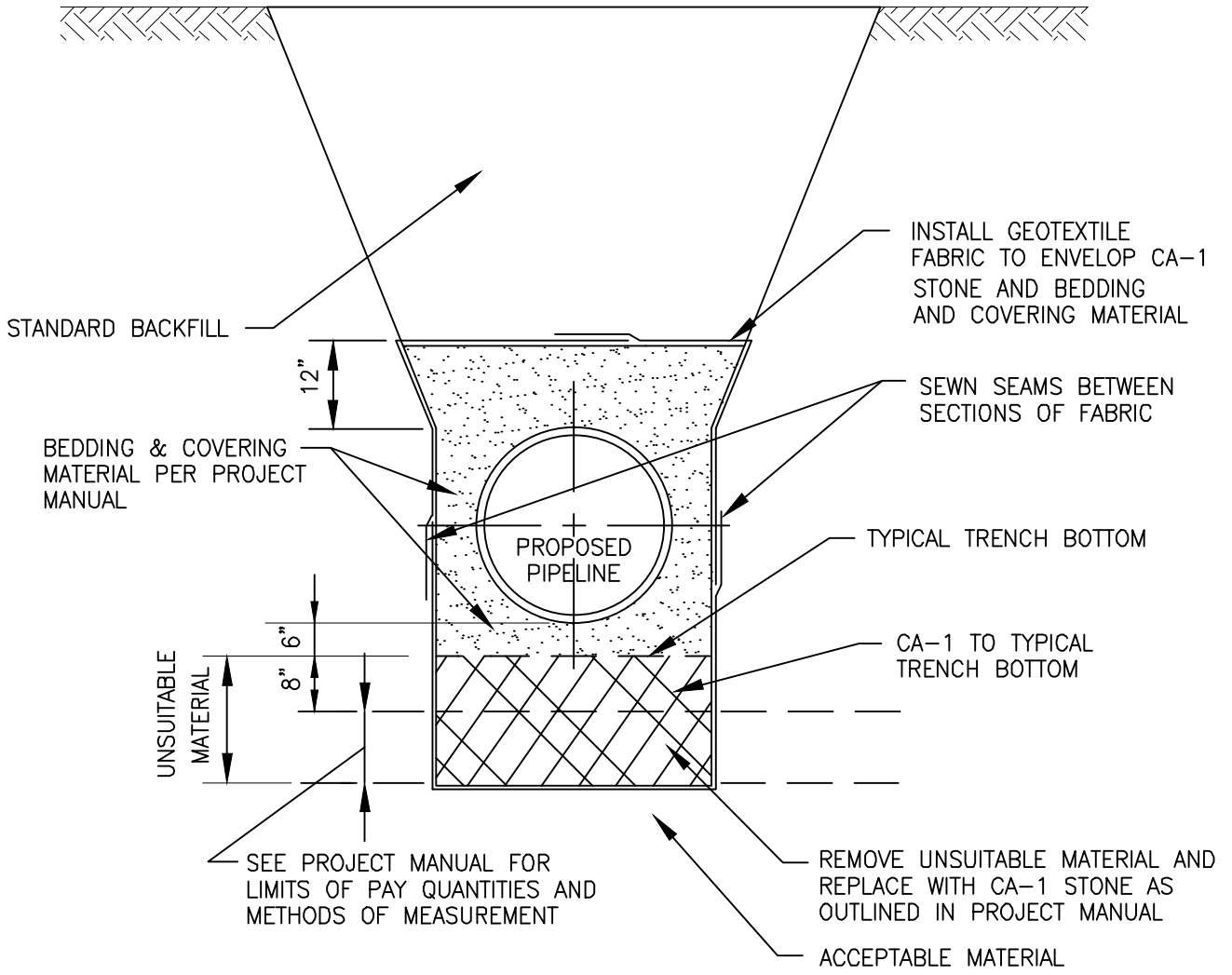

NOT TO SCALE

CITY OF JOLIET, ILLINOIS
 OPEN CUT PIPELINE
 INSTALLATION UNSUITABLE
 MATERIAL
 REMOVAL/REPLACEMENT
 GEN-03
 DATE: OCT. 2017

NOTE:
PROJECT MANUAL REFERS TO "PROJECT SPECIFICATIONS",
NOT TO IDOT STANDARD SPECIFICATIONS.

SEE PAVEMENT SECTION
DETAIL AND PROJECT MANUAL

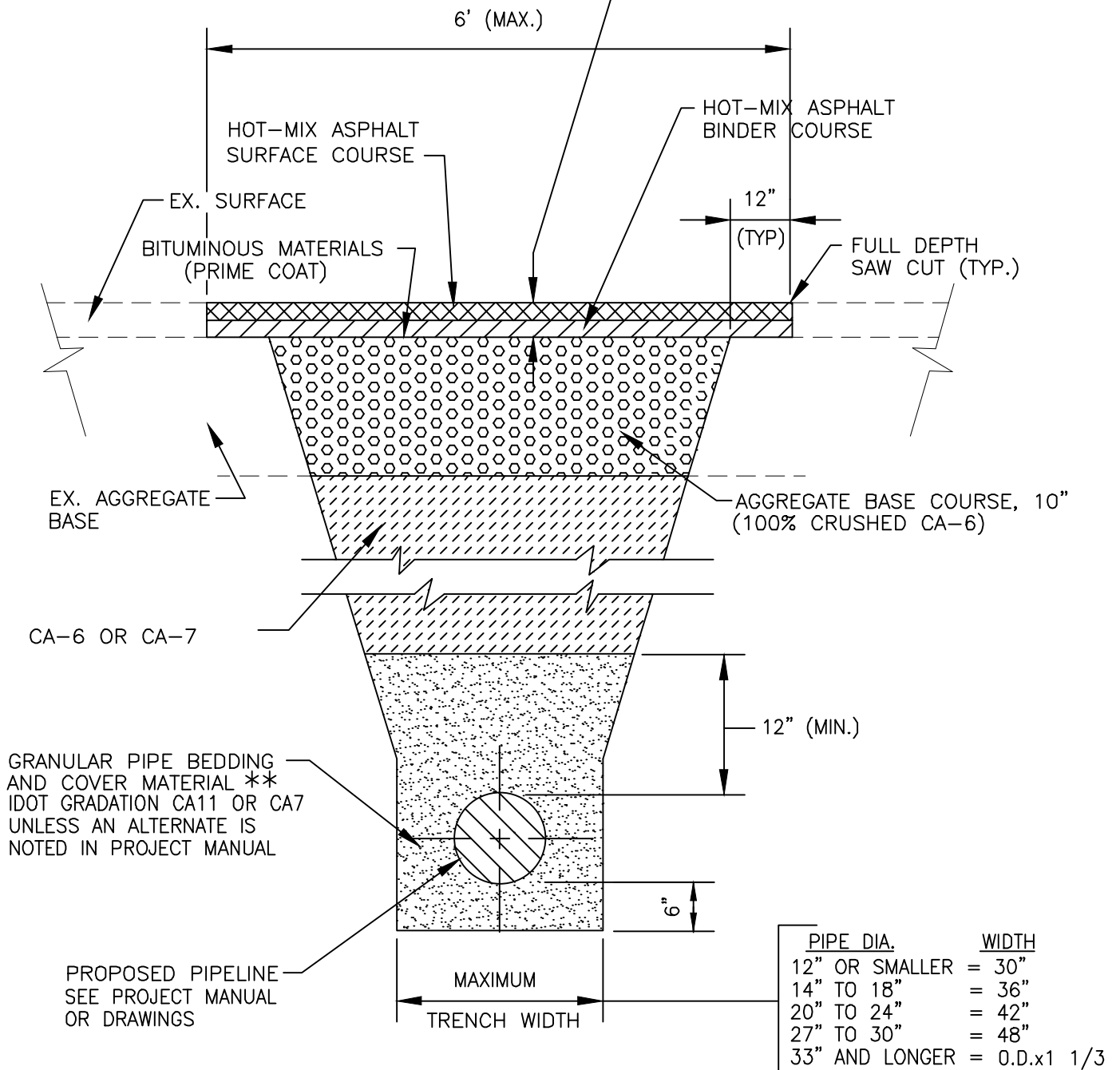

NOT TO SCALE

FOR PAVEMENT WITH AGGREGATE BASE AND
COMPACTED GRANULAR BACKFILL MATERIAL

** FOR FLEXIBLE THERMOPLASTIC PIPE COMPLY WITH ASTM D2321,
CLASS IA, IB, OR II., (IDOT GRADATION CA15)

FOR RIGID PIPE COMPLY WITH ASTM C12, BEDDING CLASS B.

CITY OF JOLIET, ILLINOIS

TYPICAL TRENCH DETAIL
PAVEMENT AREA
AGGREGATE BASE
GEN-04
DATE: OCT. 2017

NOTES:

1. PROJECT MANUAL REFERS TO "PROJECT SPECIFICATIONS", NOT TO IDOT STANDARD SPECIFICATIONS.
2. FARM FIELDS, GARDENS, AND WETLAND AREAS MAY REQUIRE STRIPPING, STOCKPILING, AND REPLACING ORIGINAL MATERIAL TO A SPECIFIC DEPTH. SEE PROJECT MANUAL OR GENERAL NOTES FOR REQUIREMENTS.

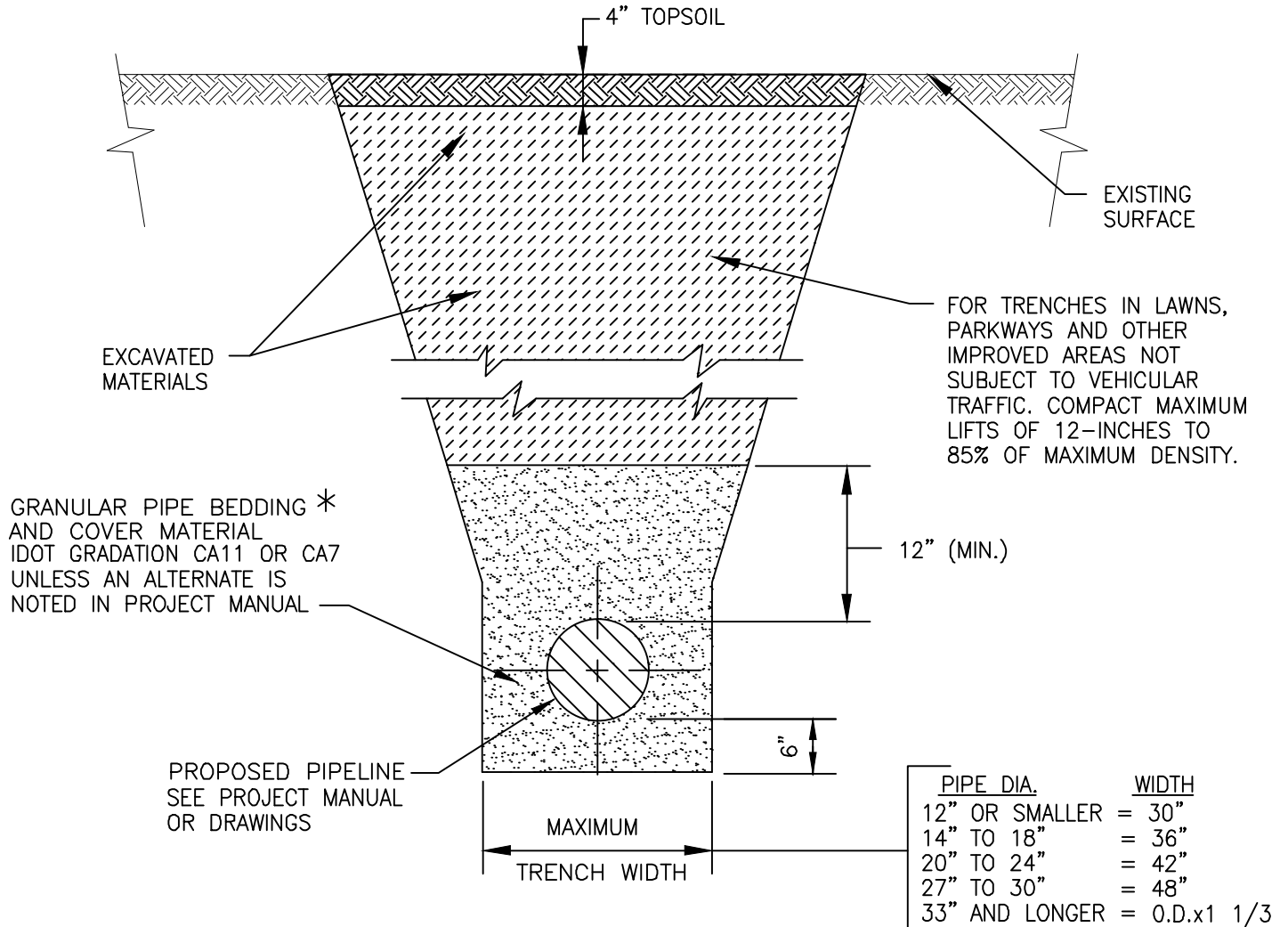

FOR NON-PAVED AREAS

NOT TO SCALE

CITY OF JOLIET, ILLINOIS

TYPICAL TRENCH DETAIL
NON PAVED AREAS
GEN-05

* FOR HDPE PIPE COMPLY WITH ASTM 2321, CLASS I OR II.
FOR RIGID PIPE COMPLY WITH ASTM C12, BEDDING CLASS B.

DATE: OCT. 2017

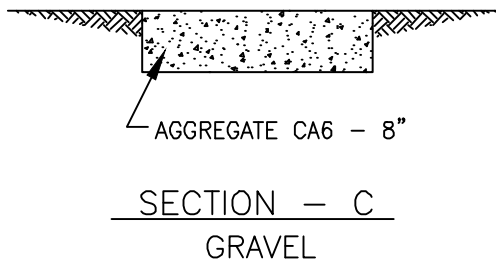
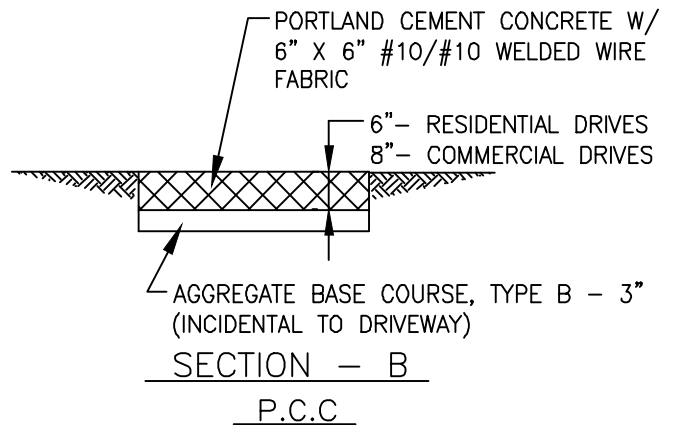
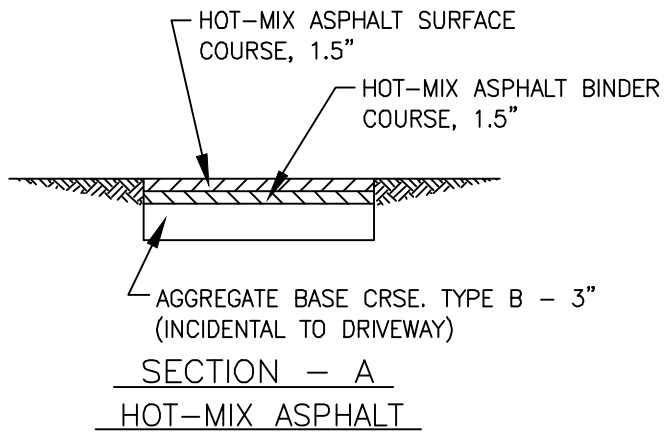
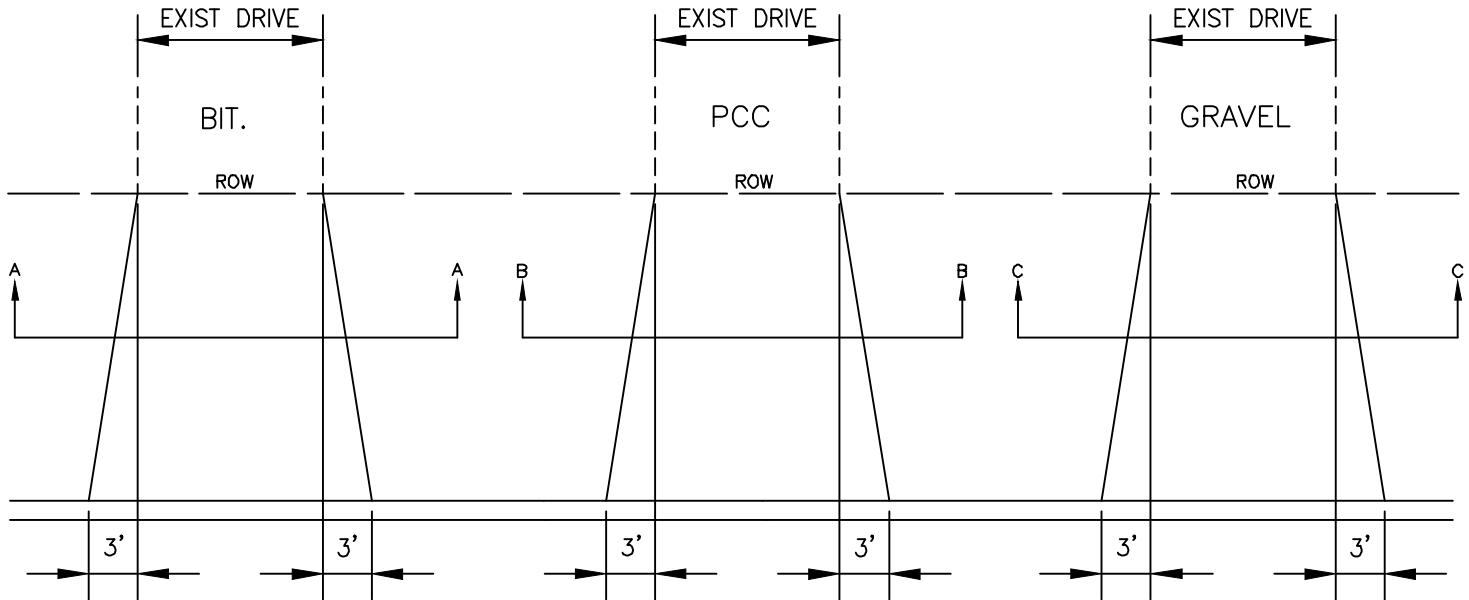

NOTES:

1. APRON: 8:1 SLOPE FROM FRONT OF SIDEWALK TO BACK OF CURB.
2. SIDEWALK: 1/4" / FT SLOPE

NOT TO SCALE

CITY OF JOLIET, ILLINOIS

DRIVEWAY PAVEMENT
DETAIL
PVT-01

DATE: OCT. 2017

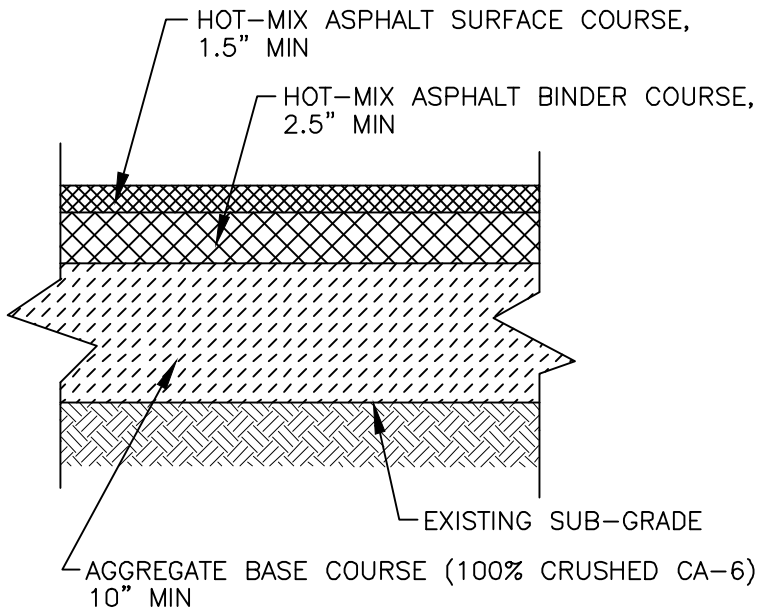

MINOR RESIDENTIAL STREETS

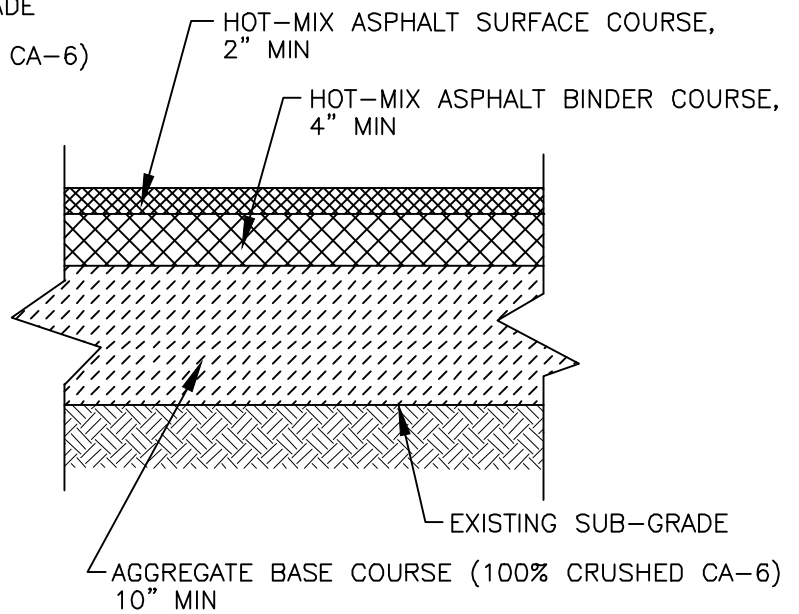

ARTERIAL STREETS

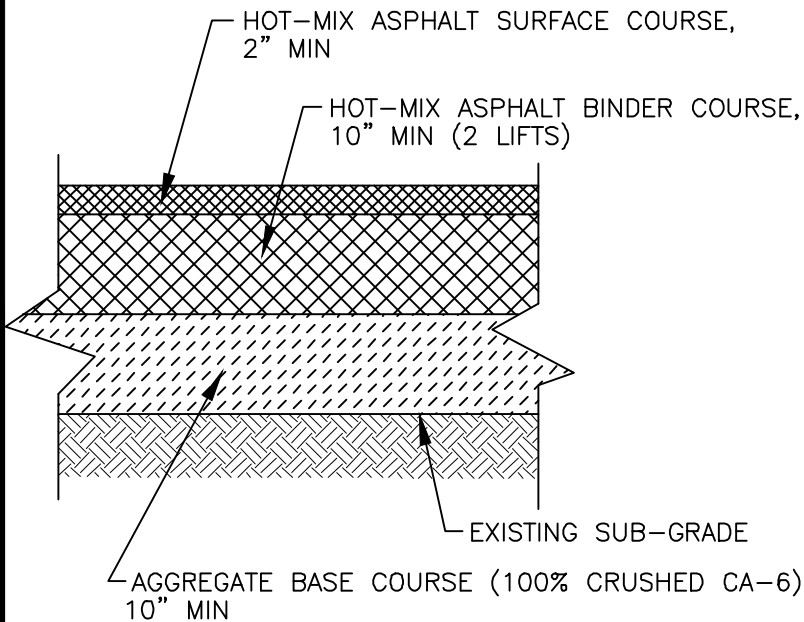

MAJOR ARTERIAL STREETS

NOTES:

1. ALL PAVEMENT PATCHES SHALL BE SAWCUT FULL-DEPTH.
2. MAXIMUM ALLOWABLE WIDTH USED FOR TRENCH RESTORATION PAY QUANTITY CALCULATIONS SHALL BE 6'.
3. DETAILS APPLY UNLESS OTHERWISE NOTED ON PLANS.

NOT TO SCALE

CITY OF JOLIET, ILLINOIS

TYPICAL PAVEMENT
SECTION
PVT-02

DATE: OCT. 2017

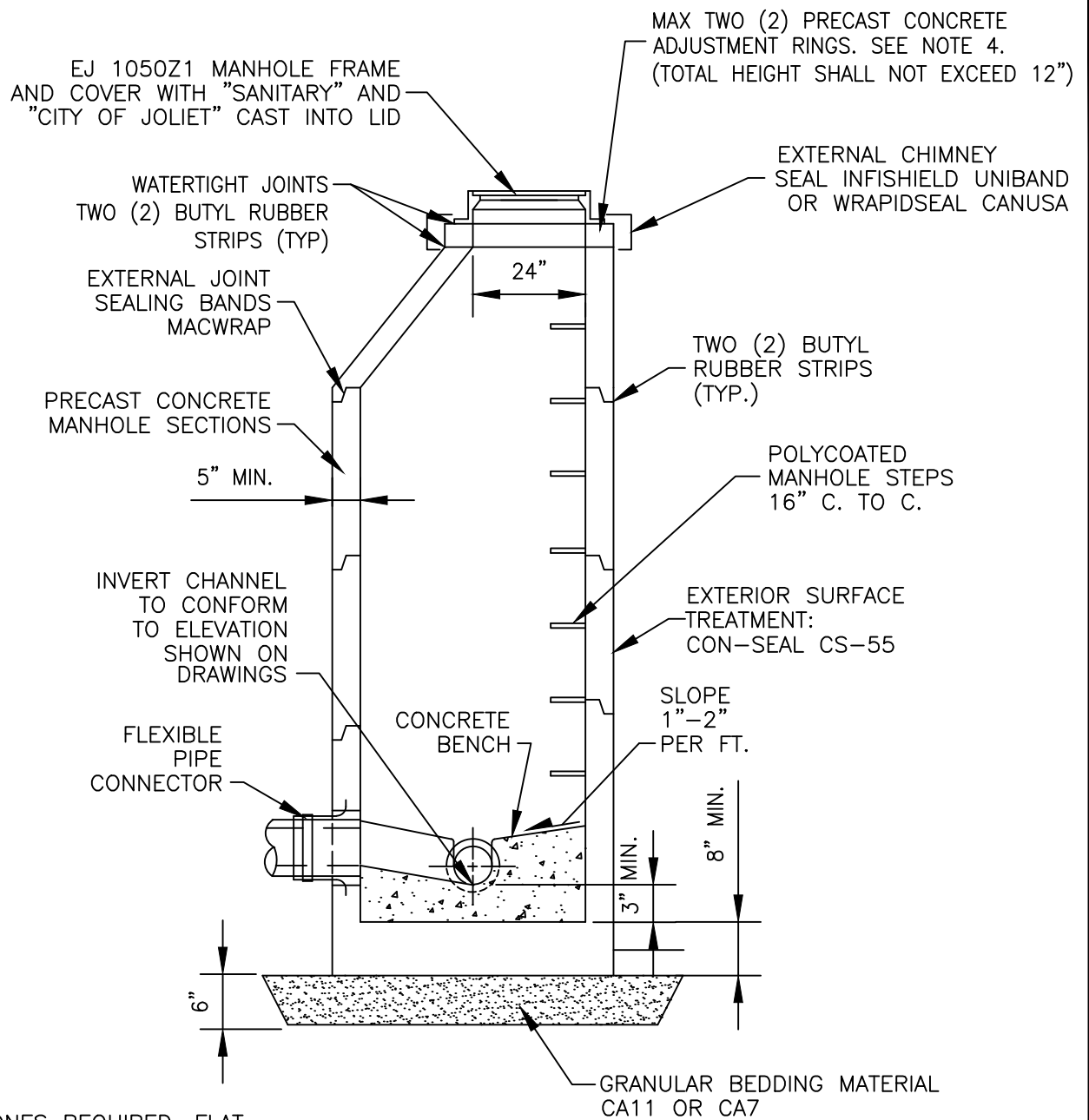

NOTE:

1. ECCENTRIC CONES REQUIRED, FLAT SLAB TOPS PERMITTED ONLY FOR MANHOLES TOO SHALLOW FOR CONES.
2. MANHOLE DIAMETER SHALL BE DETERMINED BY THE SEWER DEPTH, THE SEWER OUTSIDE DIAMETER, RELATIVE ANGLES OF SEWERS TO EACH OTHER, THE SIZE OF HOLES CORED/CAST FOR BOOTS, AND A MINIMUM OF 8" BETWEEN CORED/CAST HOLES. REFER TO DESIGN MANUAL.
3. ALL LIFT HOLES ARE TO BE GROUTED FROM THE INSIDE AND OUTSIDE BEFORE BACKFILLING.
4. FOR MANHOLES INSTALLED IN PAVEMENT, PROVIDE ONE RUBBER COMPOSITE ADJUSTMENT RING. EJ INFRA-RISER OR APPROVED EQUAL.

NOT TO SCALE

CITY OF JOLIET, ILLINOIS
 SANITARY MANHOLE DETAIL
 SAN-01

DATE: MARCH 2019

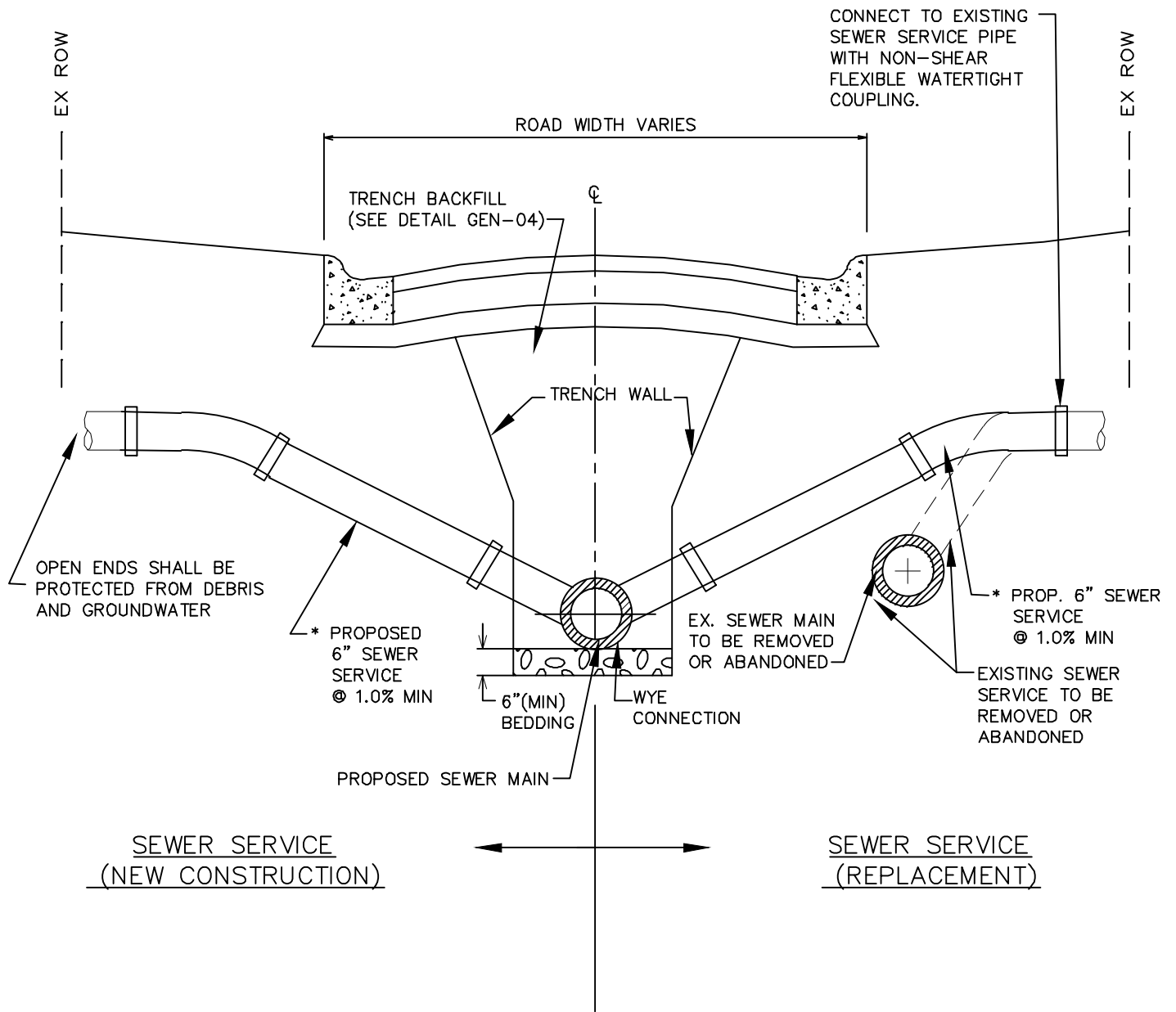

CONNECT TO EXISTING
SEWER SERVICE PIPE
WITH NON-SHEAR
FLEXIBLE WATERTIGHT
COUPLING.

EX ROW

EX ROW

ROAD WIDTH VARIES

TRENCH BACKFILL
(SEE DETAIL GEN-04)

℄

TRENCH WALL

OPEN ENDS SHALL BE
PROTECTED FROM DEBRIS
AND GROUNDWATER

* PROPOSED
6" SEWER
SERVICE
@ 1.0% MIN

EX. SEWER MAIN
TO BE REMOVED
OR ABANDONED

* PROP. 6" SEWER
SERVICE
@ 1.0% MIN

EXISTING SEWER
SERVICE TO BE
REMOVED OR
ABANDONED

6"(MIN)
BEDDING

WYE
CONNECTION

PROPOSED SEWER MAIN

SEWER SERVICE
(NEW CONSTRUCTION)

SEWER SERVICE
(REPLACEMENT)

NOT TO SCALE

* SERVICE PIPE MATERIAL: PVC SDR 26, ASTM D2241

CITY OF JOLIET, ILLINOIS

SANITARY SEWER SERVICE
SAN-02

DATE: OCT. 2017

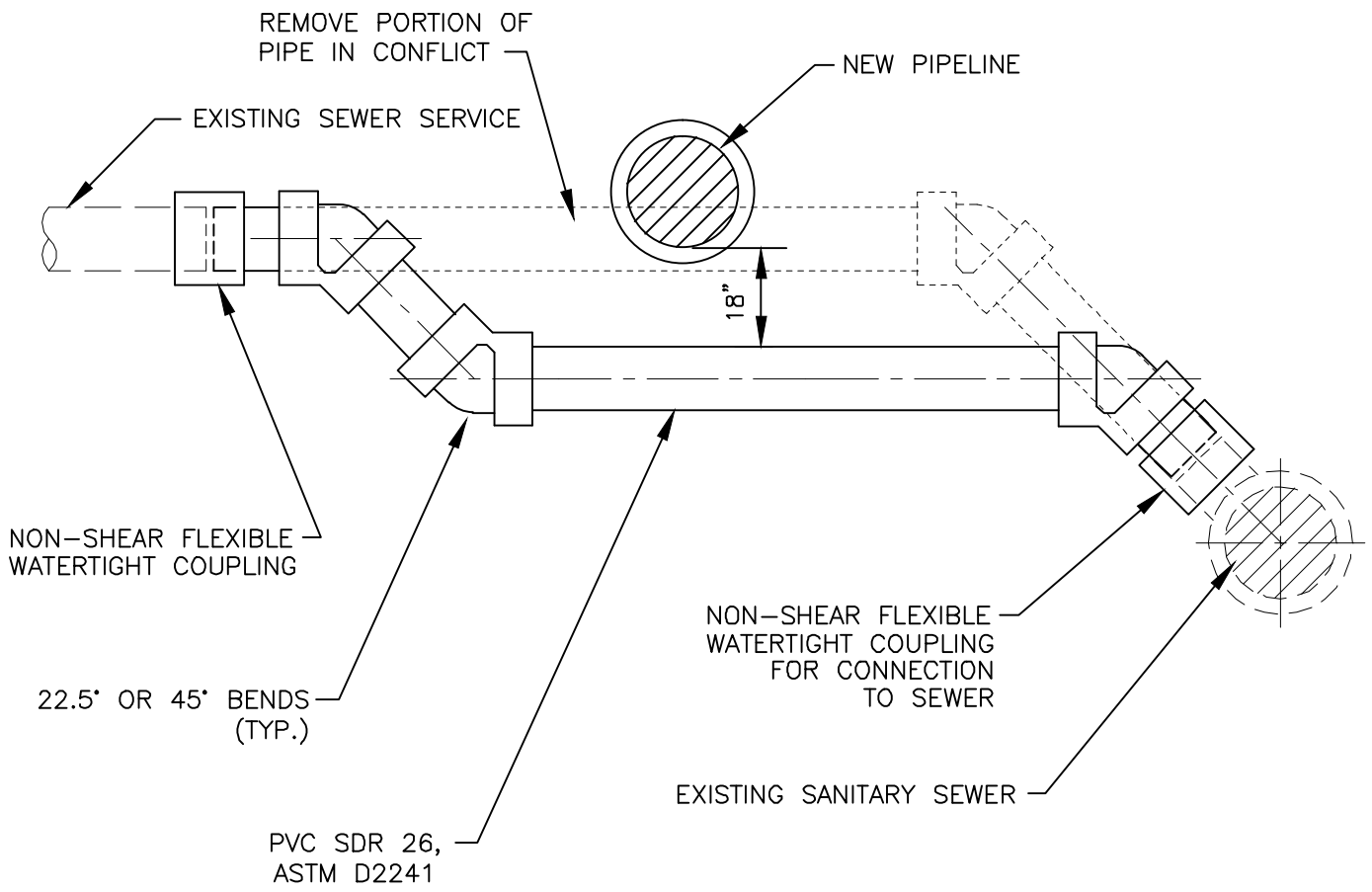

NOT TO SCALE

CITY OF JOLIET, ILLINOIS
 SANITARY SEWER SERVICE
 RELOCATION
 SAN-03
 DATE: OCT. 2017

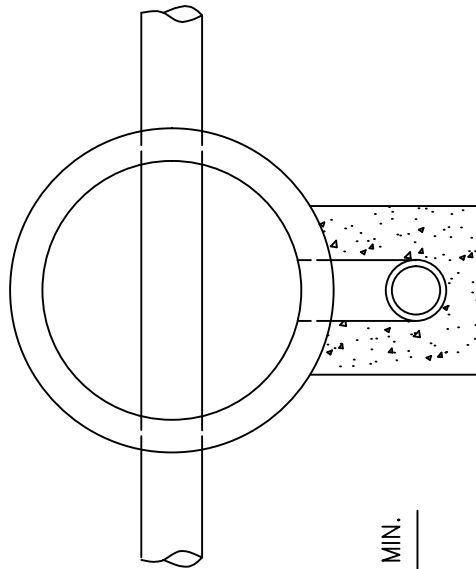

NOTE;
 USE OUTSIDE DROP WHEN ANY ENTERING
 SEWER INVERT DIFFERS BY 2'-0" OR
 MORE FROM INVERT OF MANHOLE. MATCH
 CROWN OF OUTLET PIPE WHERE OUTLET PIPE
 IS 30-INCH DIA. OR SMALLER. SEE PLAN
 SHEETS FOR INVERT ELEVATIONS FOR PIPE
 SIZES LARGER THAN 30-INCH DIAMETER.

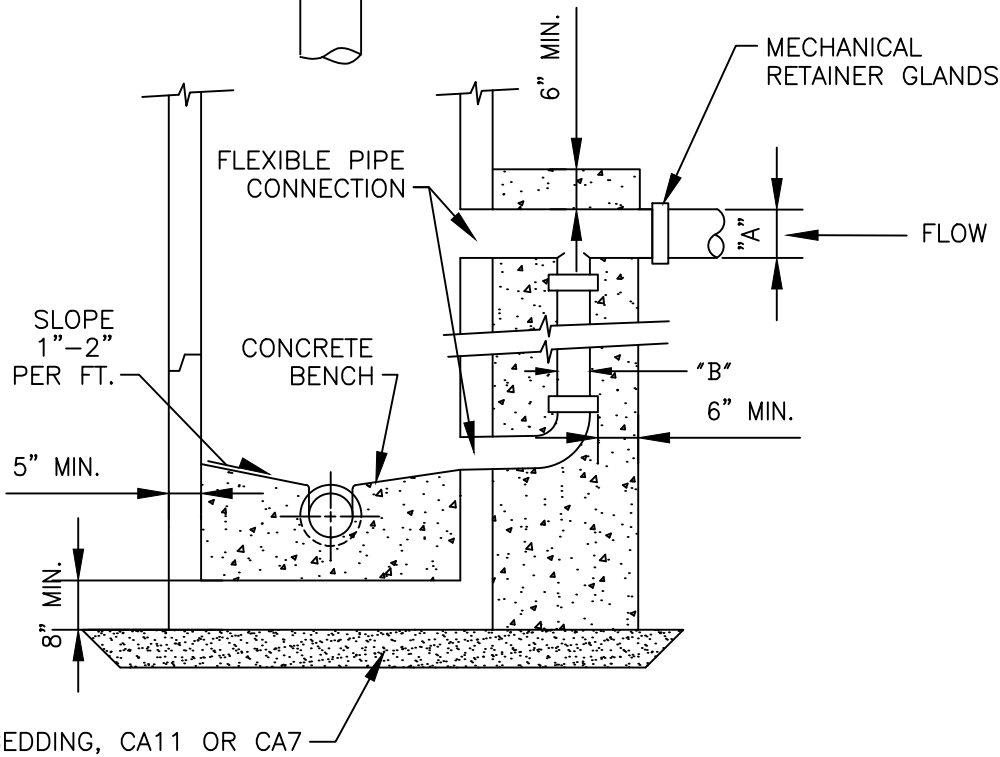

NOTES:

1. 8-INCH TO 12-INCH DIAMETER DROP: DUCTILE IRON CLASS 50. UTILIZE DUCTILE IRON RESTRAINED JOINT PIPE AND FITTINGS FOR DROP ELBOW, PIPE, AND TEE AT INCOMING SEWER. ENCASE ENTIRE DROP PIPE FROM BASE OF MANHOLE TO 6 INCHES ABOVE TOP OF INCOMING SEWER WITH 4000 PSI CONCRETE AT A MINIMUM THICKNESS OF 6 INCHES.
2. OVER 12-INCH DIAMETER DROP: DUCTILE IRON CLASS 50. ENCASE DROP ELBOW AT BASE OF MANHOLE TO 2 FEET ABOVE TOP OF ELBOW IN CONCRETE. UTILIZE DUCTILE IRON RESTRAINED JOINT PIPE AND FITTINGS FOR DROP ELBOW, PIPE, AND DUCTILE IRON TEE AT INCOMING SEWER. SUPPORT DROP PIPE TO MANHOLE WALL WITH STAINLESS STEEL BRACKETS AND STRAPPING WHERE DROPS ARE OVER 10 FEET LONG.

"A" - DIAMETER OF INCOMING SEWER
 "B" - DIAMETER OF DROP PIPE

- WHEN: "A"=12-INCH OR LESS,
 "B"="A" BUT NOT SMALLER THAN 8-INCH.
- WHEN: "A"=GREATER THAN 12-INCH, BUT
 LESS THAN OR EQUAL TO 18-INCH,
 "B"=12-INCH.
- WHEN: "A"=GREATER THAN 18-INCH,
 "B"=2/3 "A" MINIMUM.

NOT TO SCALE

CITY OF JOLIET, ILLINOIS

EXTERIOR DROP MANHOLE
 DETAIL
 SAN-04

DATE: FEBRUARY 2019

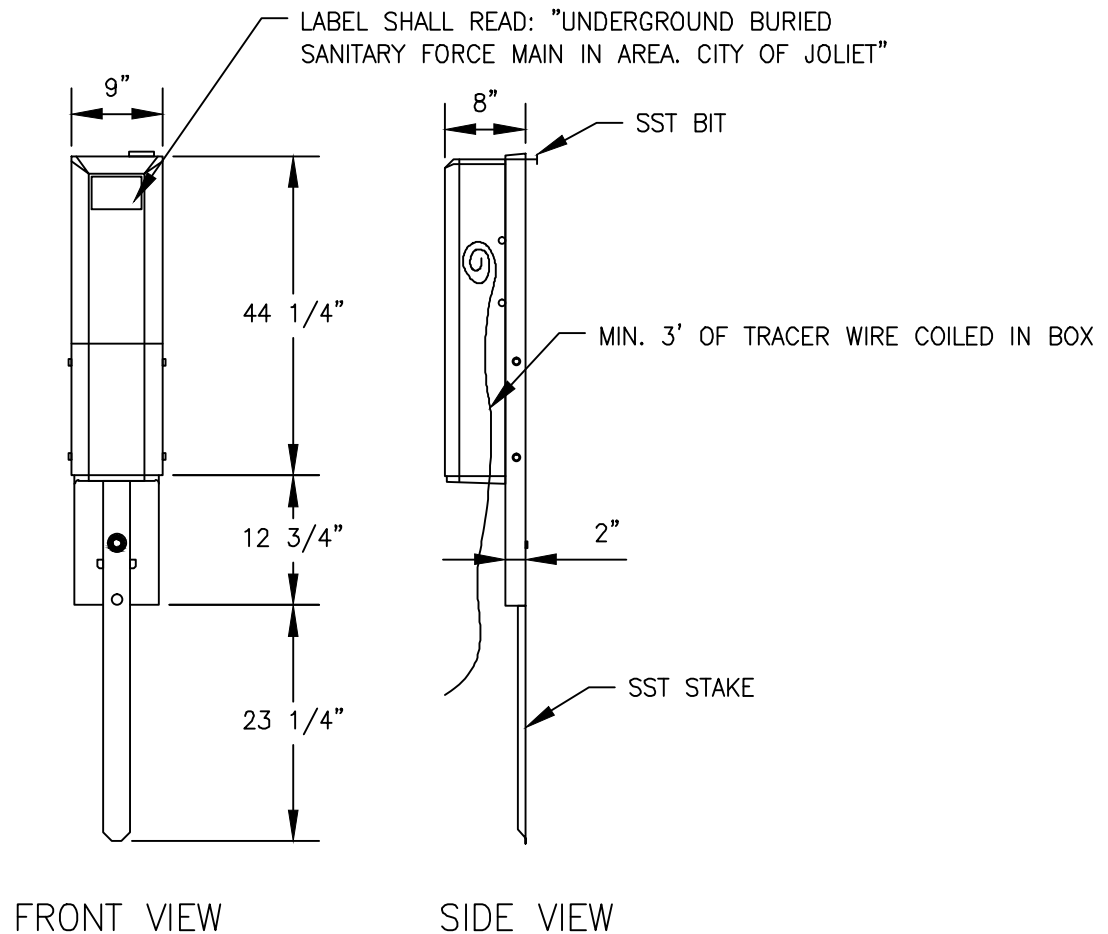

NOTES:

1. MARKER POSTS SHALL BE LOCATED A MINIMUM OF EVERY 500 FEET ALONG THE FORCE MAIN ROUTE AT THE NEAREST R.O.W. LINE. COORDINATE LOCATION WITH OWNER.
2. POST SHALL BE LOCATED AT THE R.O.W. LINE. TRACER WIRE SHALL BE INSTALLED PERPENDICULAR FROM MARKER POST TO PIPE. TRACER WIRE SHALL BE INSTALLED PER SPECIFICATIONS. TRACER WIRE SHALL BE NEPTCO TRACE SAFE.
3. MARKER POST SHALL BE NORDIC FIBERGLASS INC. WARREN MN, MODEL NUMBER P-50-MG-P-52, OR EQUAL.
4. MARKER POST SHALL BE INSTALLED AS PART OF SAME CONTRACT WITH VALVE VAULT AND VALVE. CONTRACTOR SHALL EXTEND DOWNSTREAM TRACER WIRE TO MARKER POST.

NOT TO SCALE

CITY OF JOLIET, ILLINOIS
 FORCE MAIN MARKER POST
 SAN-05

DATE: OCT. 2017

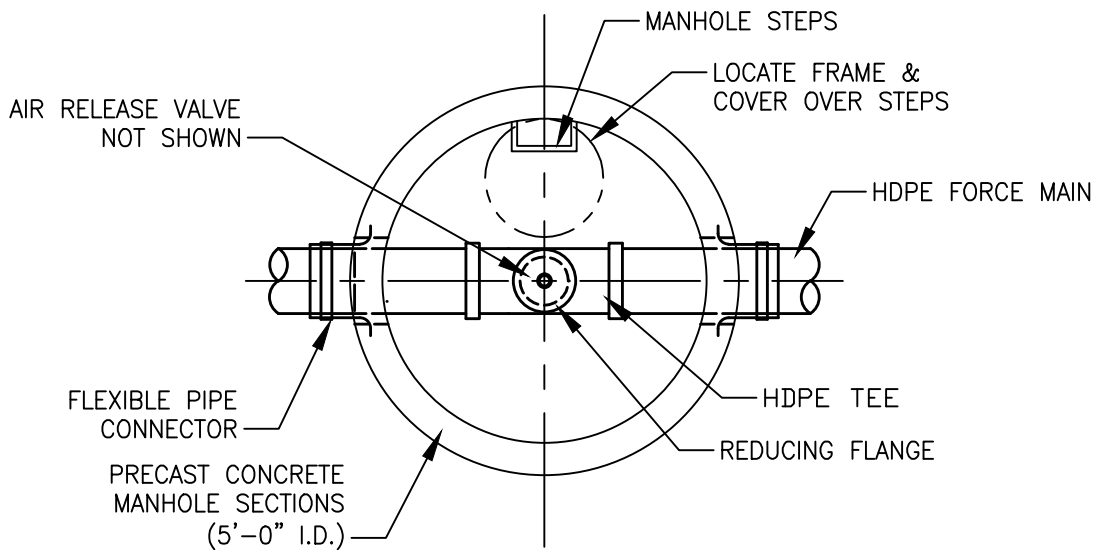

PLAN

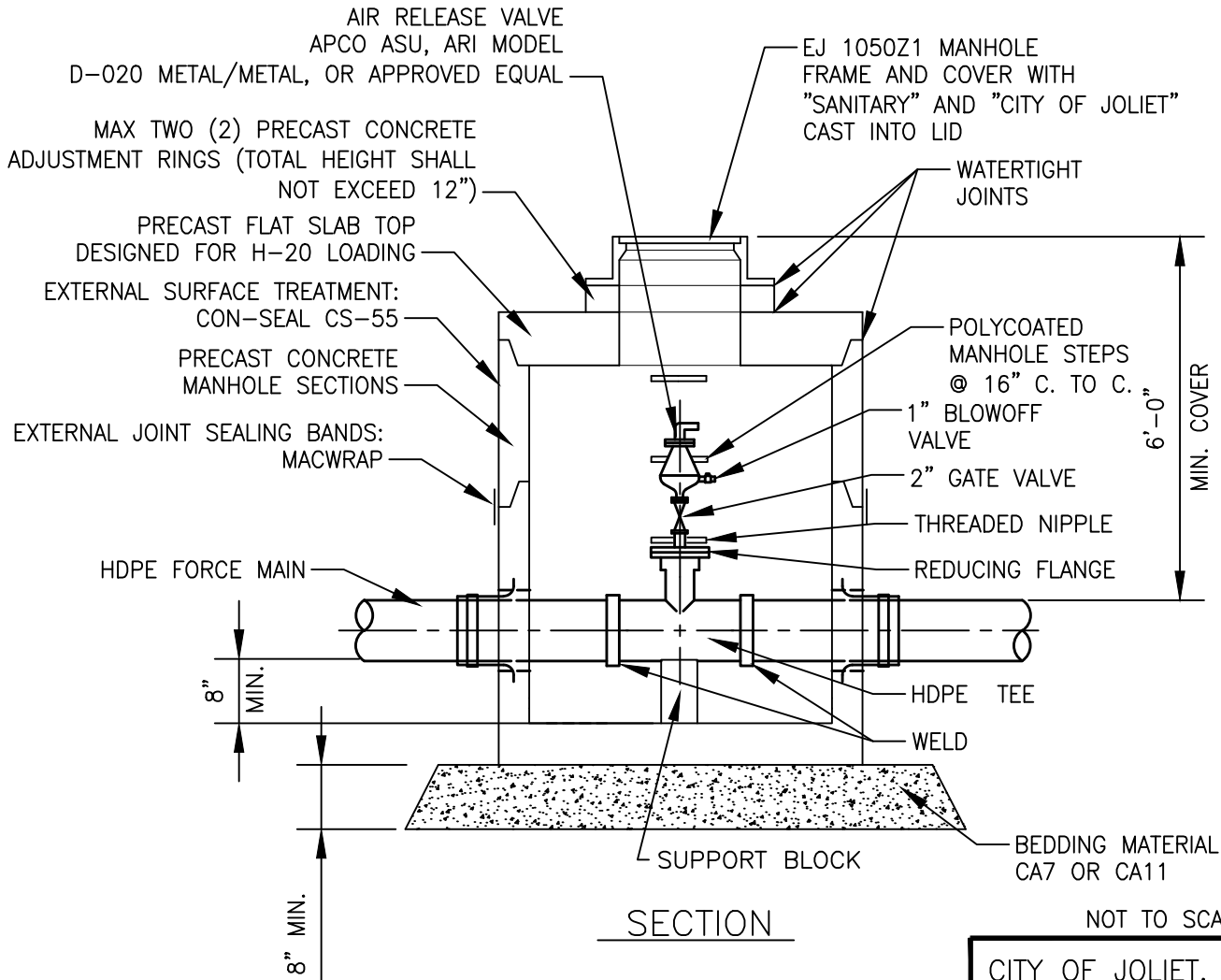

SECTION

NOT TO SCALE

CITY OF JOLIET, ILLINOIS

AIR RELEASE / VACUUM
VALVE AND VAULT
SAN-06

DATE: MARCH 2019

* DETERMINE DEPTH OF COVER AT MANHOLE BASED ON FORCE MAIN SIZE AND MANUFACTURER/MODEL OF AIR RELEASE/VACUUM VALVE. DETERMINE AND ADJUST ELEVATIONS OF FORCE MAIN PIPE ON BOTH SIDES OF MANHOLE, IF REQUIRED, TO AVOID INTERMEDIATE HIGH POINTS IN FORCE MAIN.

PALMER-BOWLUS FLUMES ARE A FORM OF THE TYPE IV FLUME, BEING DEPENDENT UPON AN EXISTING CONDUIT SLOPE AND CHANNEL CONTRACTIONS (PROVIDED BY THE FLUME) TO PRODUCE SUPERCRITICAL FLOW. THIS TYPE OF FLUME AROSE OUT OF A DESIRE TO HAVE A PRIMARY MEASURING DEVICE THAT COULD BE INSERTED INTO AN EXISTING CONDUIT, USUALLY ROUND, WITH MINIMAL SITE REQUIREMENTS OTHER THAN SUITABLE SLOPE.

Flume Size	Maximum US Slope (%)	Min Flow (gpm)	Max Flow (gpm)
6 inch	2.2	7.0	131
8 inch	2.0	14	310
10 inch	1.8	23	502
12 inch	1.6	31	752
15 inch	1.5	49	1385
18 inch	1.4	70	2071
21 inch	1.4	100	3161
24 inch	1.3	132	4248
27 inch	1.3	169	5870
30 inch	1.3	216	7410

1. THE STANDARD FLUME TYPE (PALMER BOWLUS FLUME) MUST BE SELECTED UNLESS THE SITE DOES NOT MEET THE CRITERIA BELOW. IF THE SITE DOES NOT MEET THE CRITERIA BELOW THEN THE SECONDARY FLUME (TRAPEZOIDAL) SHALL BE SELECTED FOR THE SITE.
2. THE MINIMUM FLOW FOR THE SITE (TYPICALLY IN NIGHT) AND THE MAXIMUM FLOW FOR A SITE (TYPICALLY DURING WET WEATHER EVENTS) MUST BE WITHIN THE ACCURATE FLOW RANGES DEPICTED IN TABLE 1.
3. IF THE FLOW RANGES ARE SUITABLE FOR THE MINIMUM AND MAXIMUM FLOWS OBSERVED AT THE SITE, THE FLUME SIZE SELECTED SHALL MATCH THE UPSTREAM NOMINAL PIPE SIZE.
4. THE FLUME SIZE REQUIRED TO MEET THE FLOW RANGES MUST BE WITHIN (2) NOMINAL PIPE SIZES OF THE SITE'S UPSTREAM PIPE. IF THE NOMINAL UPSTREAM PIPE SIZE AND THE FLUME SIZE ARE NOT THE SAME, A GRADUAL SMOOTH TRANSITIONAL TAPERED APPROACH FROM PIPE TO FLUME SHALL BE FORMED DURING INSTALLATION AT A 3:1 CONVERGENCE OR DIVERGENCE.
5. THE UPSTREAM PIPE'S SLOPE MUST BE LESS THAN THE MAXIMUM SLOPES IN TABLE 1 FOR THE CORRESPONDING FLUME SIZE.

STANDARD FLUME – PALMER BOWLUS FLUMES

IN AN ATTEMPT TO OBTAIN WIDER RANGES OF DISCHARGE THAN THOSE AVAILABLE WITH PALMER BOWLUS FLUMES, SEVERAL INVESTIGATORS HAVE CONSIDERED SUPERCRITICAL TRAPEZOIDAL FLUMES. TRAPEZOIDAL FLUMES GENERALLY OPERATE AS TYPE IV FLUMES. THE OUTWARD SLOPING OF THE FLUME WALLS PROVIDES INCREASED SENSITIVITY TO LOW DISCHARGE RATES FOR A GIVEN SIZE AND, HENCE, INCREASED RANGE.

Flume Size	Approach Width	Minimum Flow	Maximum Flow
Small 60 degree Trapezoidal	6	1.4	24
Large 60 degree Trapezoidal	10	5.2	116
X-Large 60 degree Trapezoidal	18	0.4	695
2-inch WSC 60 degrees	18	8.1	1126
2-inch WSC 45 degrees	24	12	1128
2-inch WSC 30 degrees	36	14	1737

1. THE MINIMUM FLOW FOR THE SITE (TYPICALLY IN NIGHT) AND THE MAXIMUM FLOW FOR A SITE (TYPICALLY DURING WET WEATHER EVENTS) MUST BE WITHIN THE ACCURATE FLOW RANGES DEPICTED IN TABLE 2.
2. IF THE FLOW RANGES FOR THE SITE DO NOT FIT WITHIN THE RANGES DEPICTED IN TABLE 1 OR TABLE 2, ALTERNATIVE FLUME TYPES OR FLOW MONITORING METHODS MUST BE DISCUSSED AND APPROVED BY THE CITY OF JOLIET.
3. IF THE FLOW RANGES ARE SUITABLE FOR THE SITE, THE FLUME SIZE SELECTED SHOULD BE THE FLUME WITH APPROACH WIDTH CLOSEST TO THE UPSTREAM NOMINAL PIPE SIZE. A GRADUAL SMOOTH TRANSITIONAL TAPERED APPROACH SHALL BE FORMED DURING INSTALLATION BETWEEN THE UPSTREAM PIPE AND THE FLUME AT A 3:1 CONVERGENCE OR DIVERGENCE.

SECONDARY FLUME – TRAPEZOIDAL FLUMES

NOTES:

1. SEE TELEDYNE ISCO OPEN CHANNEL FLOW MEASUREMENT, 7TH EDITION FOR MORE DETAIL.
2. UNLESS APPROVED BY THE CITY, THE FOLLOWING FLUMES WILL NOT BE ACCEPTED AS FLOW MEASURING DEVICES:
 - MONTANA FLUMES
 - PARSHALL FLUMES
 - LEOPOLD-LAGCO FLUMES
 - H, HS AND HL FLUMES
 - BRITISH RECTANGULAR FLUMES
 - VENTURI FLUMES
 - KHAFAGI FLUMES
 - SAN DIMAS FLUMES

NOT TO SCALE

CITY OF JOLIET, ILLINOIS
SEWER FLOW MONITORING
(GRAVITY)
SELECTION AND
SIZING OF FLUME
SAN-07

DATE: OCT. 2017

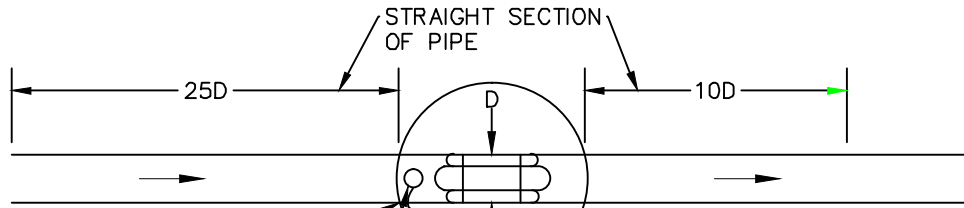

IF FLUME SIZE AND THE UPSTREAM PIPE'S NOMINAL DIAMETER DO NOT MATCH, ALLOW SPACE FOR GRADUAL TRANSITION APPROACH

MOUNT ULTRA SONIC SENSOR $D/2$ DISTANCE UPSTREAM OF THE UPPER TRANSITION OF THE FLUME

SIZE MANHOLE STRUCTURE TO FIT A FULL SIZED (OR $3D+1$) PALMER BOWLUS FLUME OF THE SELECTED DIAMETER (5' MANHOLES UP TO 15" PALMER BOWLUS FLUME)

1. FLUME SIZING AND LOCATION OF INSTALLATION MUST BE APPROVED BY THE CITY OF JOLIET BEFORE CONSTRUCTION.
2. THERE MUST BE 25 DIAMETERS LENGTH OF STRAIGHT PIPE UPSTREAM OF THE FLUME AND 10 DIAMETERS LENGTH OF STRAIGHT PIPE DOWNSTREAM OF THE FLUME, FREE OF BENDS, DROP MANHOLES, JUNCTIONS, DIAMETER CHANGES, AND TURBULENCE.
3. THE UPSTREAM SLOPE MUST BE LESS THAN THE MAXIMUM SLOPE FOR THE SELECTED SIZE FLUME. THE DOWNSTREAM SLOPE MUST BE GREAT ENOUGH TO MAINTAIN A SUBMERGENCE RATIO OF LESS THAN 85%.
4. INSTALLATION OF THE FLUME AND METER SENSOR SHALL BE PER MANUFACTURER'S SPECIFICATIONS. SOME GENERAL NOTES INCLUDE:
 - 4.1. FLUME MUST BE LEVEL IN ALL DIRECTIONS.
 - 4.2. FLUME MUST BE ANCHORED (USING THREADED ROD) TO THE BENCH BEFORE GROUTING TO ENSURE FLOATING DOES NOT OCCUR.
 - 4.3. THERE MUST BE A GRADUAL SMOOTH TRANSITIONAL TAPERED APPROACH BETWEEN THE UPSTREAM PIPE AND THE FLUME.
 - 4.4. THE ULTRASONIC SENSOR MUST BE LEVEL IN ALL DIRECTIONS AND MOUNTED $D/2$ DISTANCE UPSTREAM OF THE UPPER TRANSITION.
 - 4.5. THE ULTRASONIC SENSOR MUST BE PROPERLY CALIBRATED AND OBSERVED BY CITY REPRESENTATIVE. (NOTE: $H = \text{DEPTH} - D/6$)

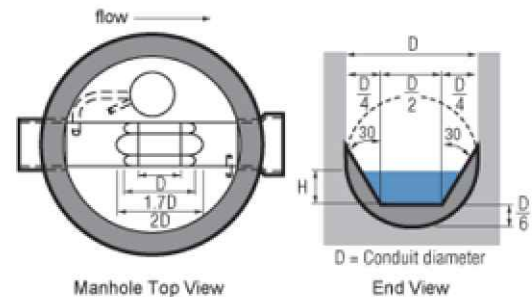
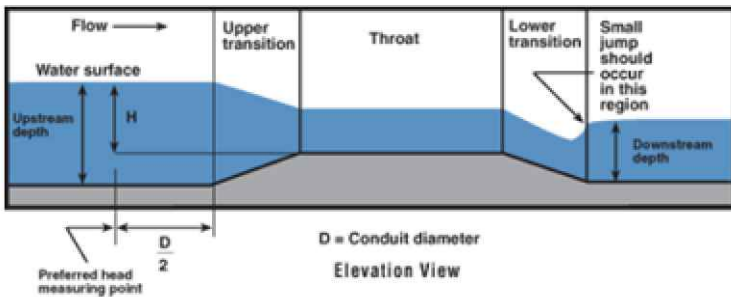

Permanent Type

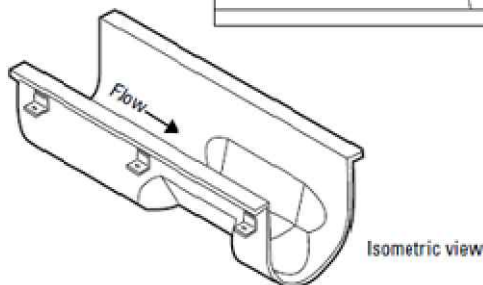
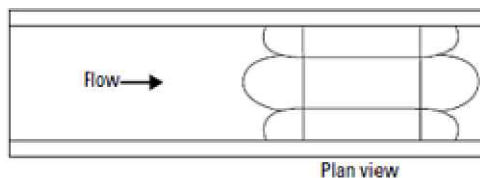

PALMER BOWLUS FLUME

CITY OF JOLIET, ILLINOIS
SEWER FLOW MONITORING
(GRAVITY)
PALMER BOWLUS FLUME
INSTALLATION
SAN-08

DATE: OCT. 2017

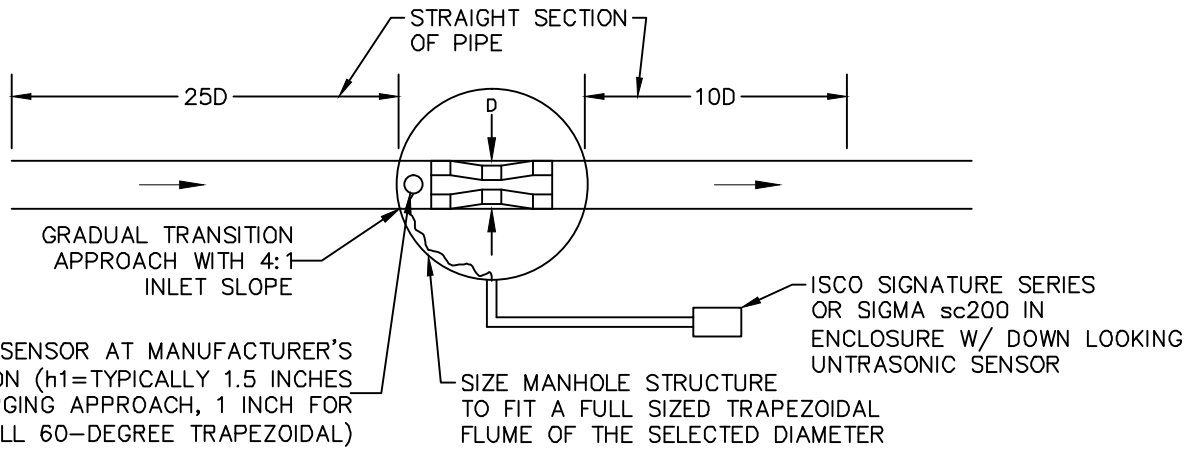

1. FLUME SIZING AND LOCATION OF INSTALLATION MUST BE APPROVED BY THE CITY OF JOLIET BEFORE CONSTRUCTION.
2. THERE MUST BE 25 DIAMETERS LENGTH OF STRAIGHT PIPE UPSTREAM OF THE FLUME AND 10 DIAMETERS LENGTH OF STRAIGHT PIPE DOWNSTREAM OF THE FLUME, FREE OF BENDS, DROP MANHOLES, JUNCTIONS, DIAMETER CHANGES, AND TURBULENCE.
3. THE UPSTREAM SLOPE MUST BE LESS THAN THE MAXIMUM SLOPE FOR THE SELECTED SIZE FLUME. THE DOWNSTREAM SLOPE MUST BE GREAT ENOUGH TO MAINTAIN A SUBMERGENCE RATIO OF LESS THAN 80%.
4. INSTALLATION OF THE FLUME AND METER SHALL BE PER MANUFACTURER'S SPECIFICATIONS. SOME GENERAL NOTES INCLUDE:
 - 4.1. FLUME MUST BE LEVEL IN ALL DIRECTIONS.
 - 4.2. FLUME MUST BE ANCHORED (USING THREADED ROD) TO THE BENCH BEFORE GROUTING TO ENSURE FLOATING DOES NOT OCCUR.
 - 4.3. THERE MUST BE A GRADUAL SMOOTH TRANSITIONAL TAPERED APPROACH BETWEEN THE UPSTREAM PIPE AND THE FLUME BETWEEN THE UPSTREAM PIPE AND THE FLUME AT MANUFACTURER'S RECOMMENDED LOCATION.
 - 4.4. THE ULTRASONIC SENSOR MUST BE LEVEL IN ALL DIRECTIONS AND MOUNTED D/2 DISTANCE UPSTREAM OF THE UPPER TRANSITION OF THE FLUME.
 - 4.5. THE ULTRASONIC SENSOR MUST BE PROPERLY CALIBRATED AND OBSERVED BY CITY REPRESENTATIVE.

Flume Type	b ₁	b ₂	A	L	C	D	E	F	H	B	R	S	U	W	θ	h ₁
Small 60 degree Trapezoidal	2"	0	5"	4 1/8"	4 3/64"	5"	2"	4 3/4"	4"	20 3/32"	1"	2 3/8"	2 1/2"	6 1/4"	60°	1"
Large 60 degree Trapezoidal	2"	0	7"	7"	6 15/16"	7"	3"	8"	6 3/4"	30 7/8"	1 1/2"	4"	3 1/2"	10"	60°	1 1/2"
X-Large 60 degree Trapezoidal	3 3/4"	0	7"	7 7/8"	6 15/16"	18"	3"	13 7/8"	12"	41 7/8"	1 1/2"	7 1/2"	9"	18 3/8"	60°	1 1/2"
2-inch WSC 60 degrees	4 7/8"	2"	8"	8 1/2"	8 13/32"	8 1/2"	3"	14"	10 3/8"	36 5/16"	1 1/2"	6"	4 1/4"	16 7/8"	60°	1 1/2"
2-inch WSC 45 degrees	4 7/8"	2"	8"	8 1/2"	8 3/8"	8 1/2"	3"	22 13/16"	10 19/32"	36 1/4"	1 1/2"	10 19/32"	4 1/4"	26 1/16"	45°	1 1/2"
2-inch WSC 30 degrees	4 7/8"	2"	8"	8 1/2"	8 3/8"	8 1/2"	3"	36 41/64"	10"	36 1/4"	1 1/2"	17 5/16"	4 1/4"	39 33/64"	30°	1 1/2"

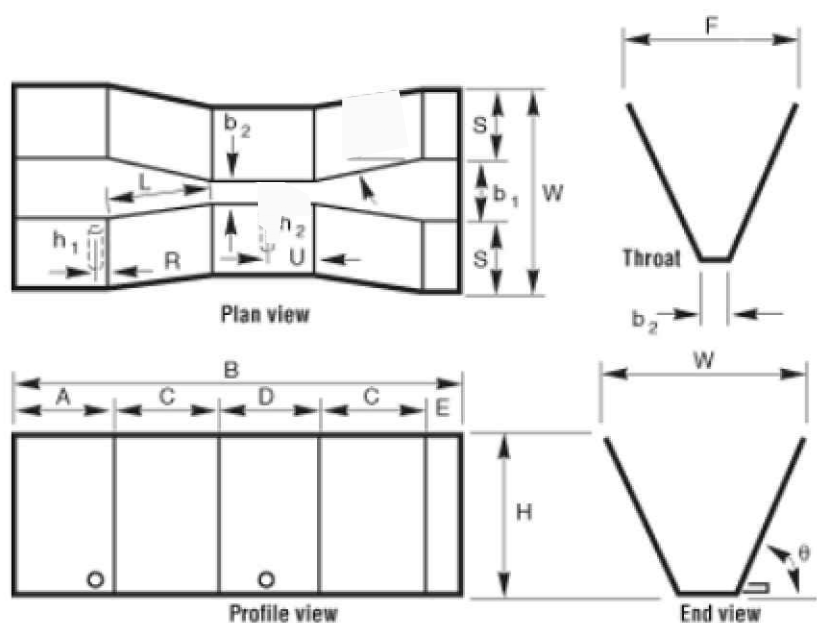

TRAPEZOIDAL FLUME

NOT TO SCALE

CITY OF JOLIET, ILLINOIS
SEWER FLOW MONITORING
(GRAVITY)
TRAPEZOIDAL FLUME
INSTALLATION
SAN-09

DATE: OCT. 2017

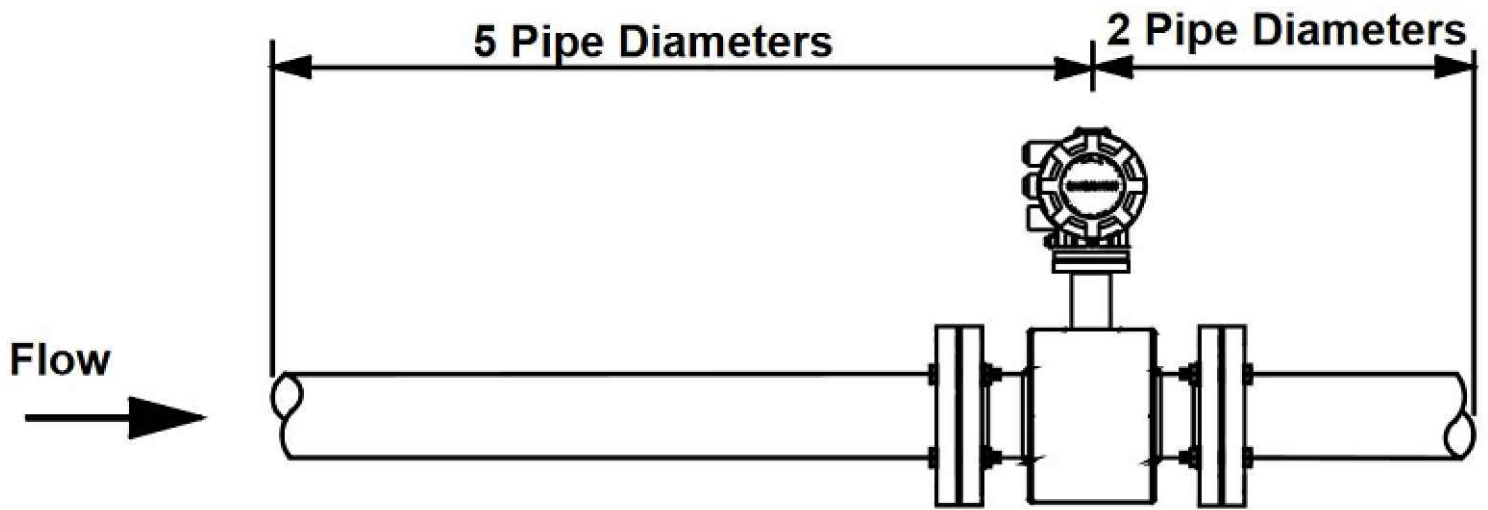

1. MAG METER MUST BE MANUFACTURED BY ABB OR SIEMENS.
2. MAG METER MUST HAVE DUAL 4–20 mA ANALOG OUTPUT CHANNELS.
3. MAG METER SHALL BE INSTALLED PER MANUFACTURER'S SPECIFICATIONS. AT LEAST 5 PIPE DIAMETERS AND 2 PIPE DIAMETERS OF STRAIGHT PIPE SPOOL ARE REQUIRED UPSTREAM AND DOWNSTREAM OF THE MAG METER.
4. PIPE SUPPORTS SHALL BE INSTALLED ONLY ON THE PIPE SPOOL (AND NOT THE MAG METER).
5. GASKETS SHALL BE THE SAME DIAMETER OF PIPE.

MAGNETIC FLOW METER

NOT TO SCALE

CITY OF JOLIET, ILLINOIS
SEWER FLOW MONITORING
(PRESSURIZED)

WASTE WATER MAG METER
INSTALLATION
SAN-10

DATE: OCT. 2017

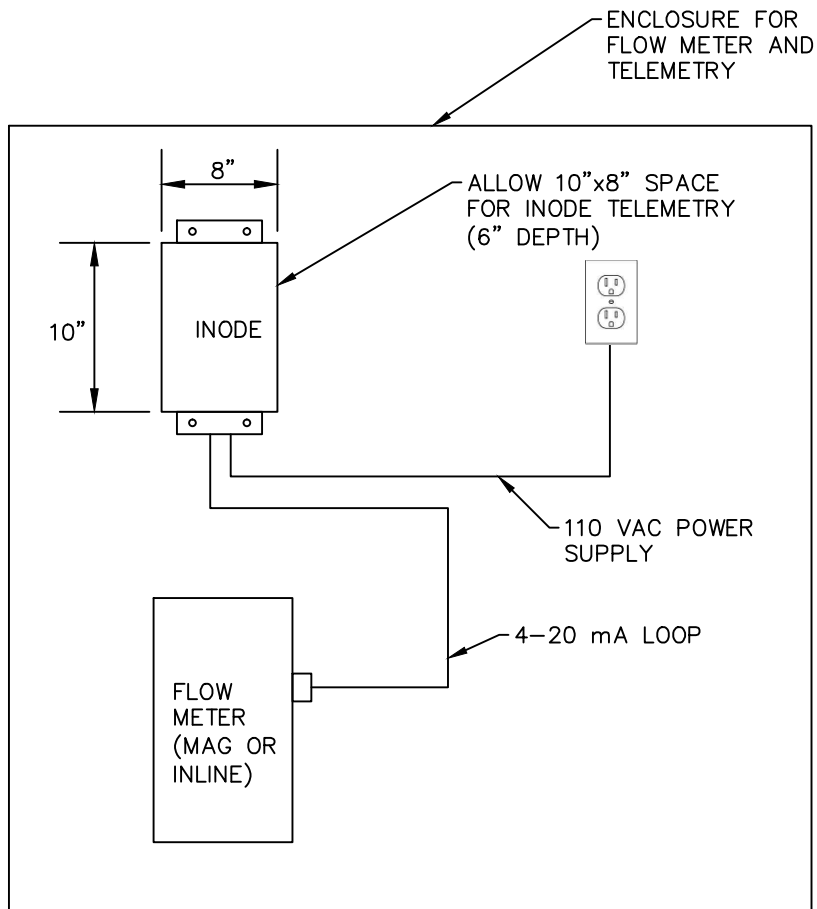

1. MOUNT INODE INTO ENCLOSURE.
2. ENCLOSURE SHALL HAVE 110 VAC POWER SUPPLY.
3. SET UP CURRENT LOOP WITH FLOW MONITORS 4-20 mA ANALOG OUTPUT.
4. INODE MUST HAVE AN INPUT FOR A PULSE TOTALIZER.

INODE TELEMETRY FOR PERMANENT MONITORING SITES

NOTE:

1. PURCHASING CONTACT: EMNET, LLC, WWW.EMNET.NET, 121 S. NILES AVE., SOUTH BEND, IN 46617, PHONE: 574.855.1012

NOT TO SCALE

CITY OF JOLIET, ILLINOIS
SEWER FLOW MONITORING
(GRAVITY)

INODE TELEMETRY FOR PERMANENT
MONITORING SITES

SAN-11

DATE: MARCH 2019

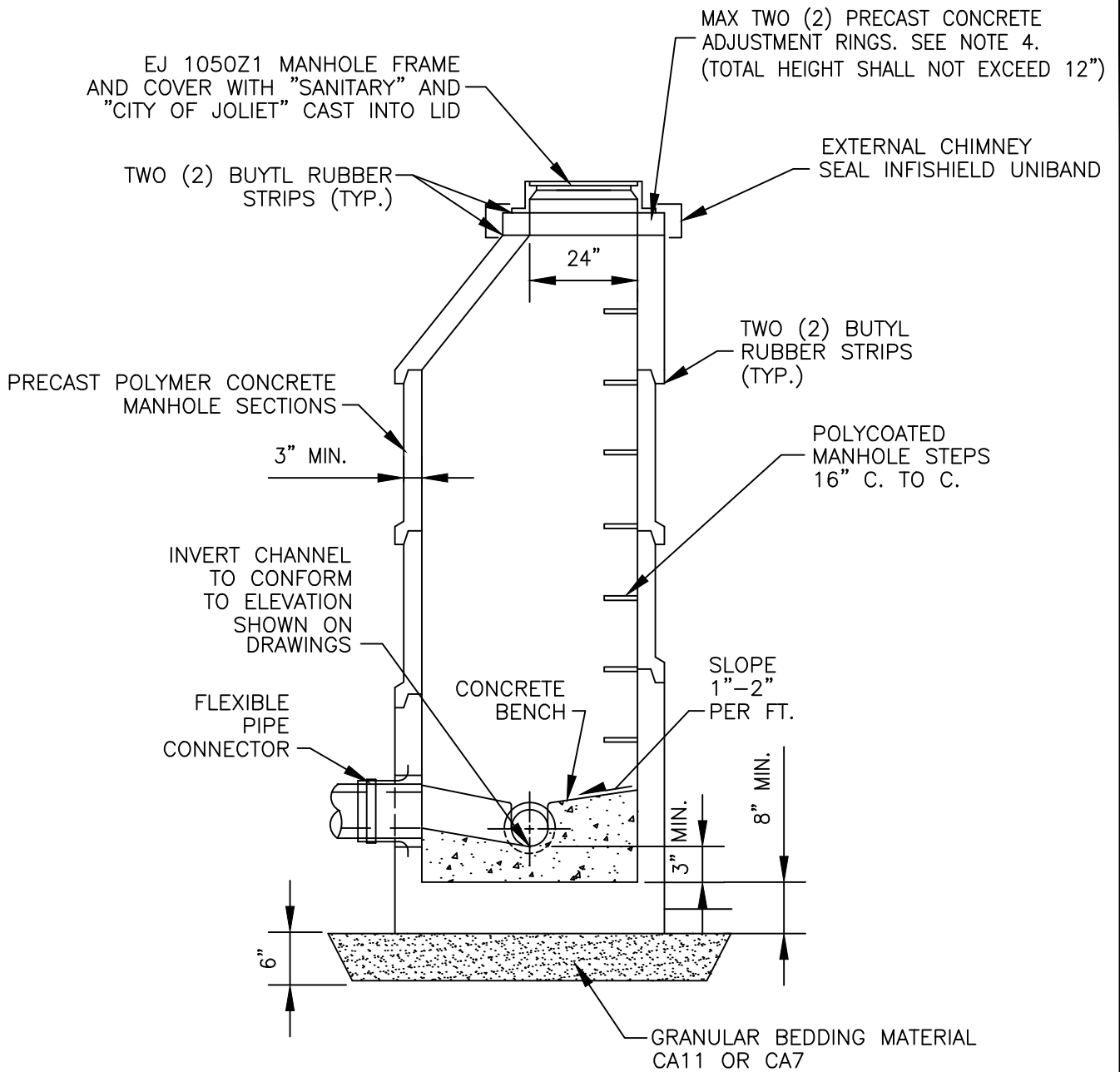

NOTE:

1. ECCENTRIC CONES REQUIRED, FLAT SLAB TOPS PERMITTED ONLY FOR MANHOLES TOO SHALLOW FOR CONES.
2. MANHOLE DIAMETER SHALL BE DETERMINED BY THE SEWER DEPTH, THE SEWER OUTSIDE DIAMETER, RELATIVE ANGLES OF SEWERS TO EACH OTHER, THE SIZE OF HOLES CORED/CAST FOR BOOTS, AND A MINIMUM OF 8" BETWEEN CORED/CAST HOLES. REFER TO DESIGN MANUAL.
3. ALL LIFT HOLES ARE TO BE GROUTED FROM THE INSIDE AND OUTSIDE BEFORE BACKFILLING.
4. FOR MANHOLES INSTALLED IN PAVEMENT, PROVIDE ONE RUBBER COMPOSITE ADJUSTMENT RING. EJ INFRA-RISER OR APPROVED EQUAL.
5. BOUYANCY DESIGN SUBMITTALS ARE REQUIRED.

NOT TO SCALE

CITY OF JOLIET, ILLINOIS

SANITARY POLYMER
MANHOLE DETAIL
SAN-12

DATE: MARCH 2019

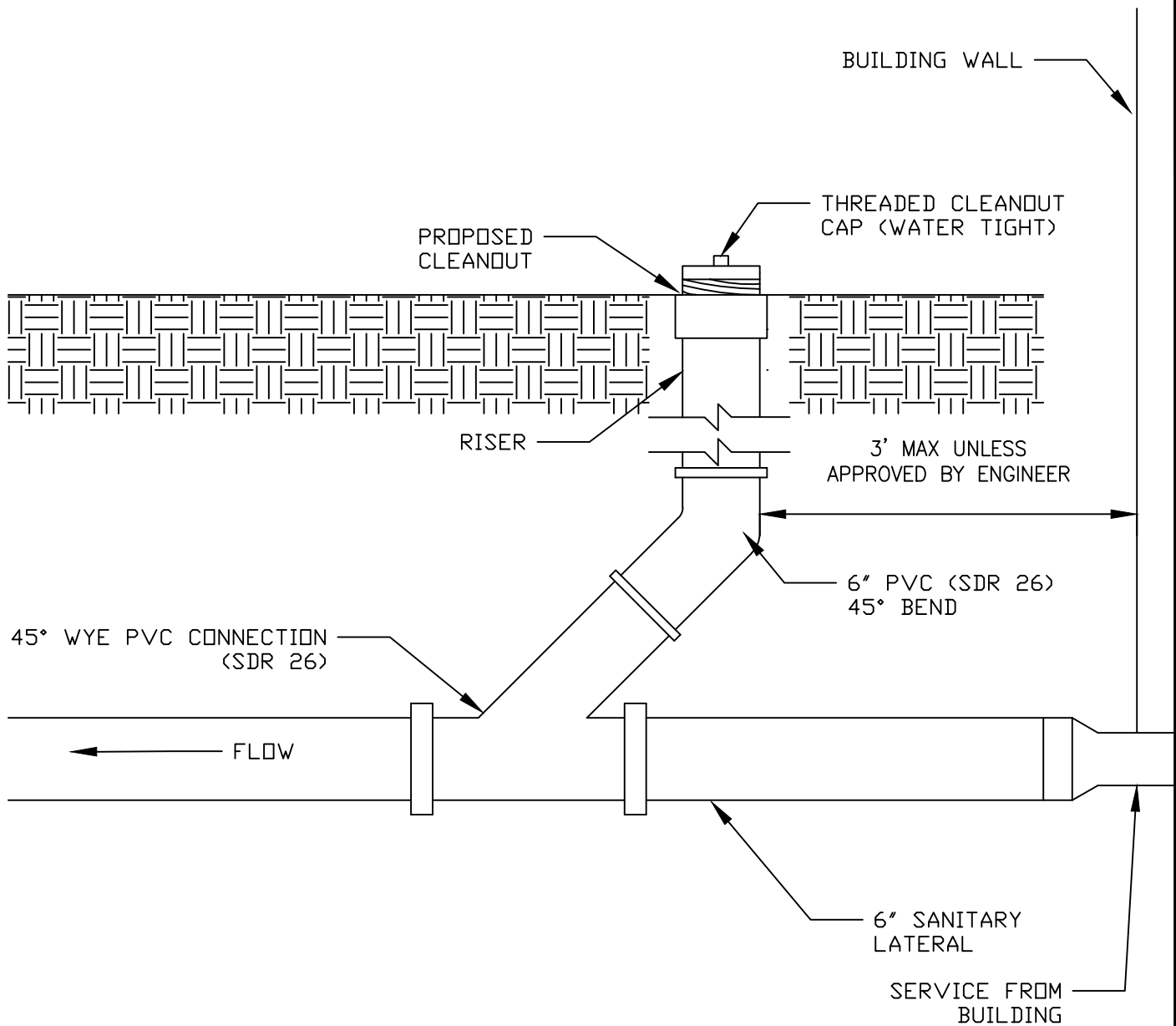

NOTE;

1. PROPOSED CLEANOUT TO BE INSTALLED FLUSH TO THE EXISTING SURFACE.
2. CLEANOUT SHALL BE INSTALLED AS CLOSE TO BUILDING AS POSSIBLE
3. CONNECTIONS TO DISSIMILAR MATERIAL PIPES SHALL BE MADE WITH NON-SHEAR MISSION COUPLINGS WITH STAINLESS STEEL BANDS
4. CLEANOUTS IN PAVED AREAS SHALL BE INSTALLED WITH EAST JORDAN 1574 CAST IRON CLEANOUT. FRAME AND LID INSTALLED FLUSH WITH FINISHED SURFACE.

NOT TO SCALE

CITY OF JOLIET, ILLINOIS

SANITARY SERVICE
CLEANOUT DETAIL
SAN-13

DATE: NOVEMBER 2022

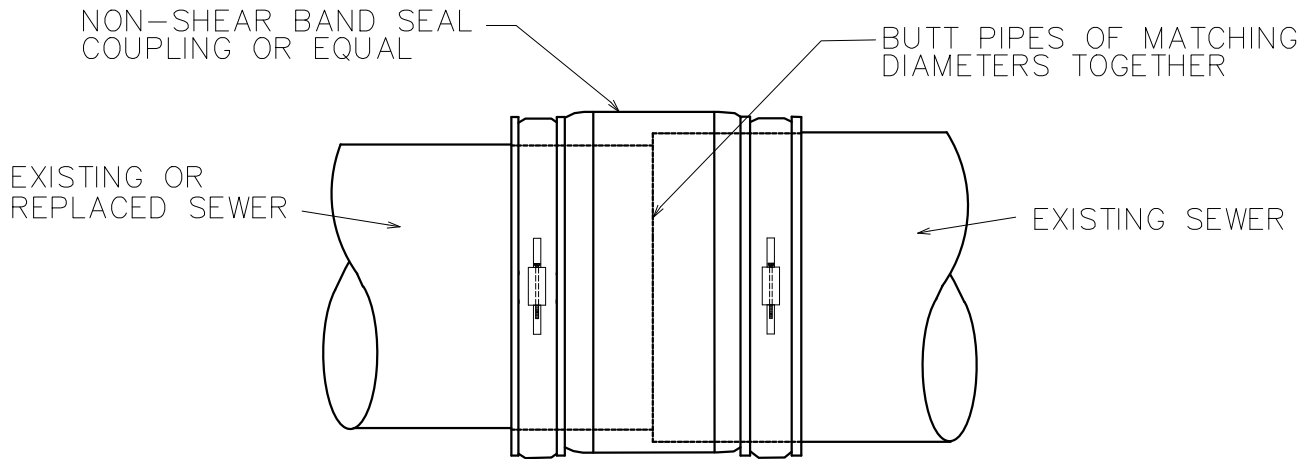

PIPE COUPLING DETAIL

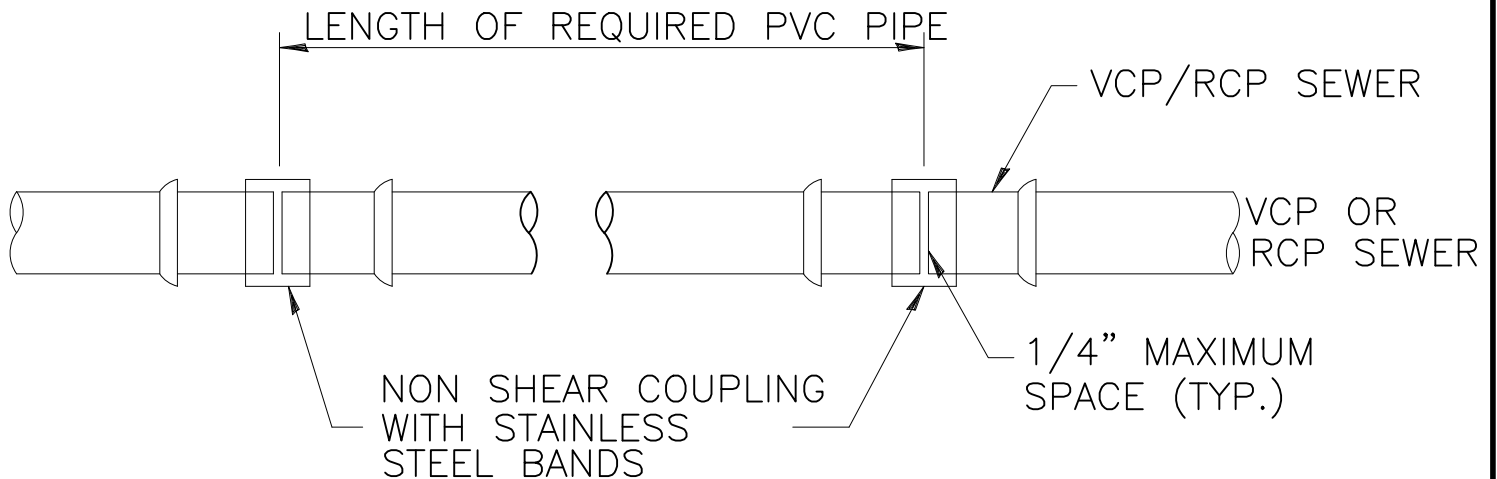

NOTES:

1. CONNECTION TO CIPP LINING SHALL BE NON-SHEAR COUPLINGS THAT ARE MADE SPECIFICALLY TO FIT THE OUTSIDE DIAMETER OF CURED-IN-PLACE PIPE (CIPP)

NOT TO SCALE

CITY OF JOLIET, ILLINOIS

CONNECTING SEWER PIPES
OF DISSIMILAR MATERIAL
SAN-14

DATE: NOVEMBER 2022

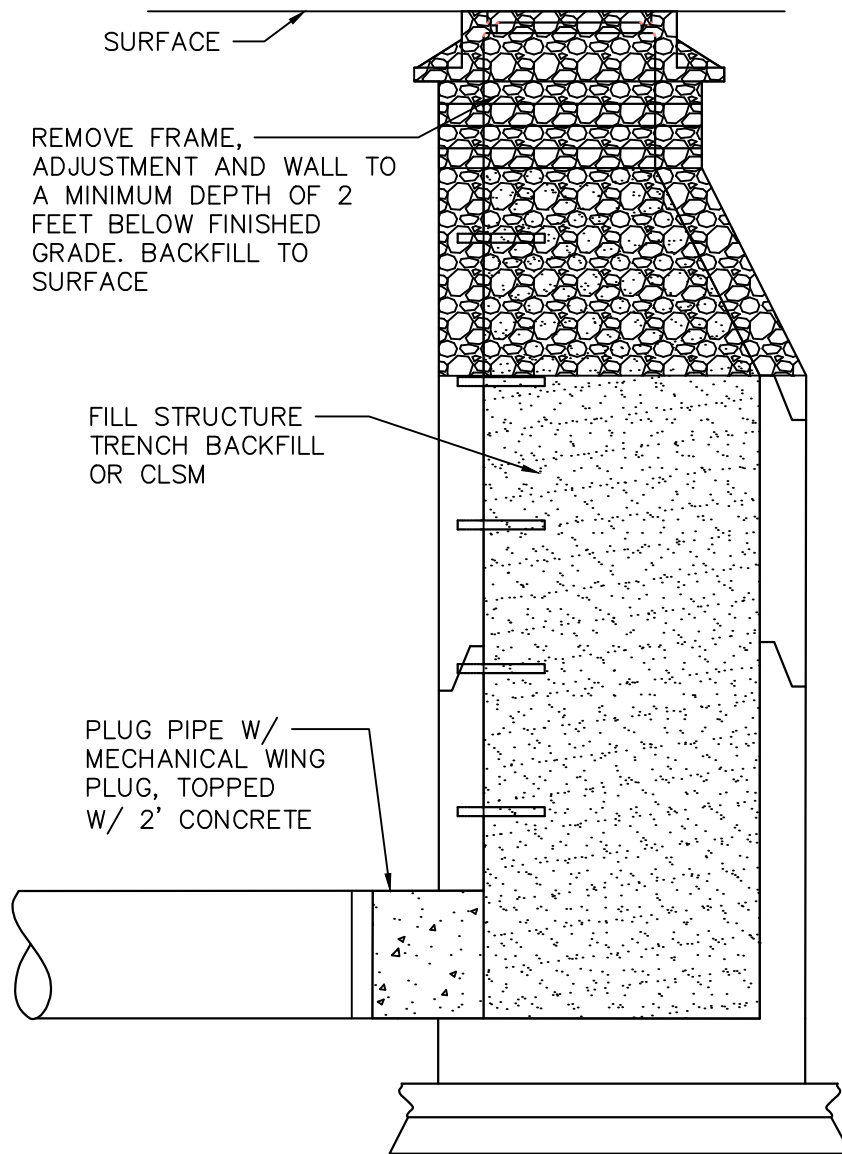

NOTE:

- ALL CONNECTING PIPES SHALL BE PLUGGED WITH MECHANICAL WING PLUGS OF THE SPECIFIED DIAMETER AND TOPPED WITH CONCRETE PLUG. BRICK AND MORTAR PLUGS WILL NOT BE ACCEPTABLE IN LIEU OF CONCRETE.
- THE MINIMUM THICKNESS OF THE CONCRETE TO THE PLUG SHALL BE TWO PIPE DIAMETERS UP TO 24 INCHES.
- CONTRACTOR SHALL REMOVE FRAME, COVER, CONE AND ADJUSTMENT RINGS OF THE MANHOLE STRUCTURES, AND CONE/FLAT-TOP/WALL TO A MINIMUM OF TWO (2') FEET BELOW FINISHED GRADE.
- REMAINDER OF THE STRUCTURE IS TO BE FILLED WITH TRENCH BACKFILL.
- CONTRACTOR SHALL BE RESPONSIBLE FOR OFF-SITE DISPOSAL OF ADJUSTMENT RINGS, FRAME AND COVER MUST BE RETURNED TO THE CITY.

NOT TO SCALE

CITY OF JOLIET, ILLINOIS

STRUCTURE ABANDONMENT
SAN-15

DATE: NOVEMBER 2022

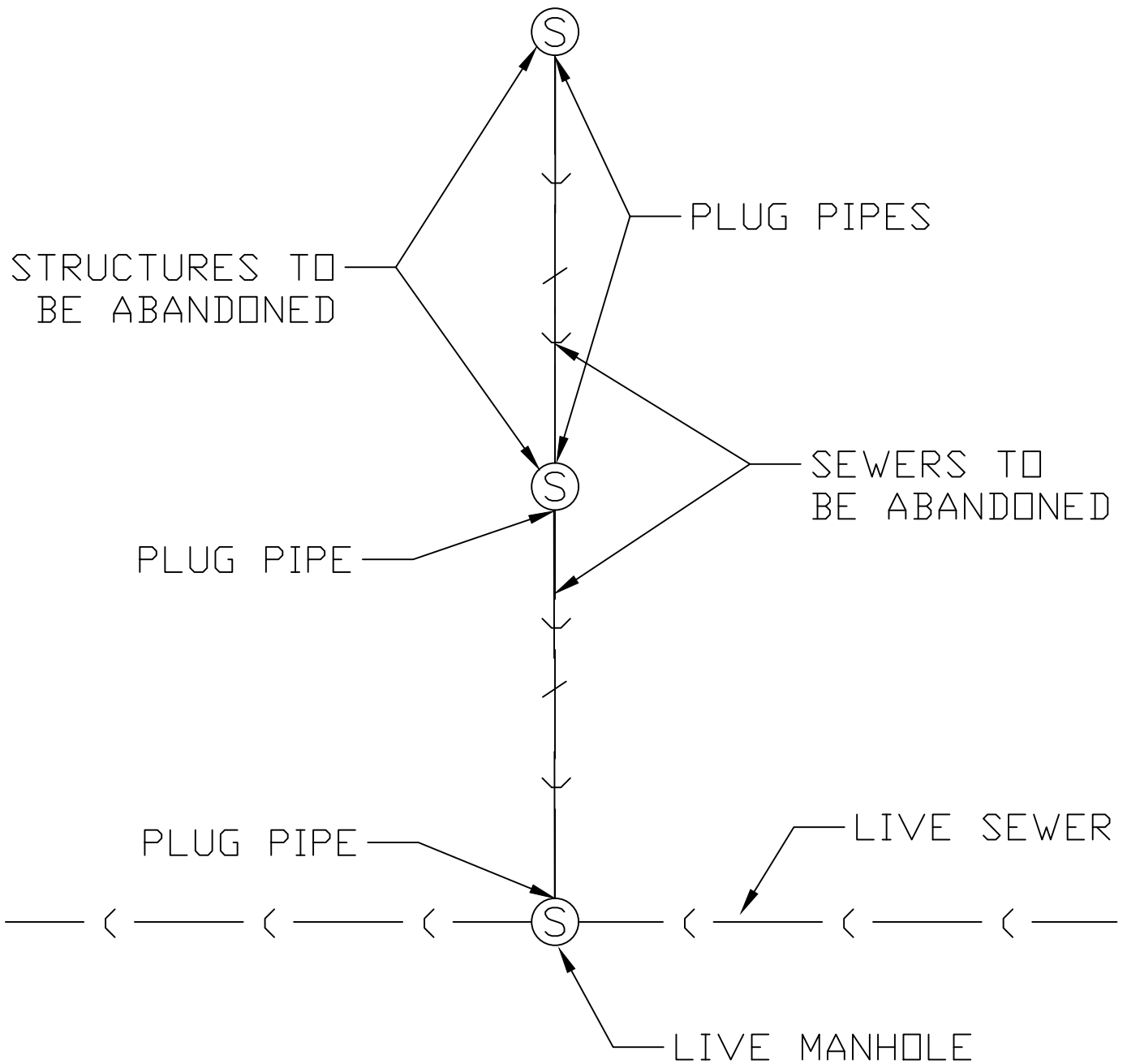

NOTE:

- REMOVE ABANDONED SEWERS IF WITHIN TRENCH OR IF DIRECTED BY ENGINEER.
- FILL ABANDONED PIPES WITH CLSM IF WITHIN IDOT, COUNTY OR RAIL ROAD RIGHT OF WAY.
- FILL ABANDONED PIPES WITH CLSM IF PIPE DIAMETER IS 15-INCHES OR GREATER.
- PLUG ALL PIPES IN STRUCTURES TO BE ABANDONED
- ABANDON STRUCTURES PER THE "ABANDONMENT OF STRUCTURES" DETAIL (SAN-15).

NOT TO SCALE

CITY OF JOLIET, ILLINOIS
 ABANDONMENT OF SEWERS
 SAN-16

DATE: NOVEMBER 2022

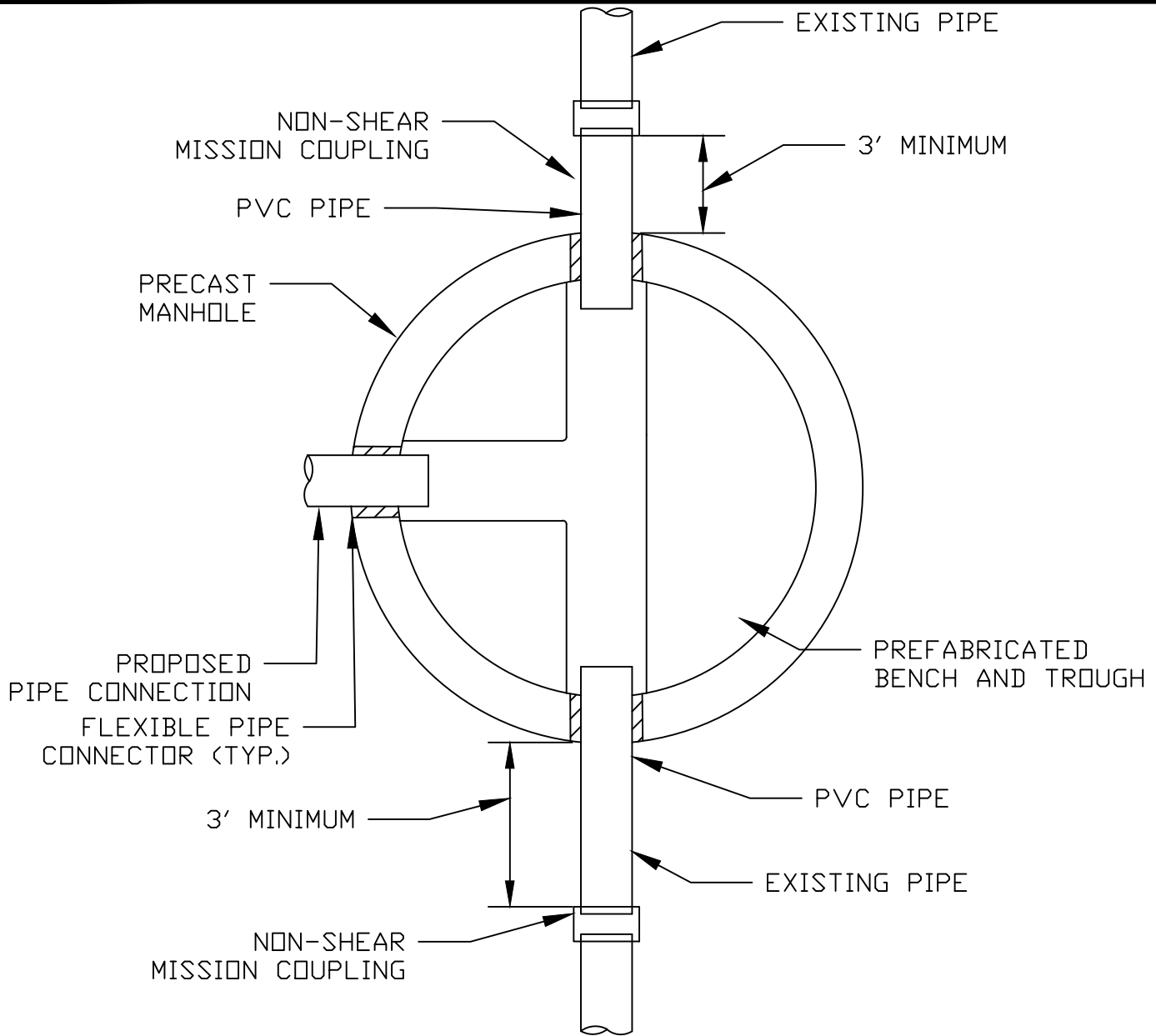

NOTE:

1. MANHOLE INSTALLATION MUST CONFORM TO CITY OF JOLIET STANDARD MANHOLE DETAIL (SAN-01).
2. EXTERNAL DROP CONNECTION MUST BE PROVIDED IF INVERT OF CONNECTING SEWER IS 24" OR MORE ABOVE THE INVERT OF OUTLET.
3. DOGHOUSE MANHOLES WILL NOT BE ACCEPTED UNLESS APPROVED BY THE ENGINEER.

NOT TO SCALE

CITY OF JOLIET, ILLINOIS

NEW SANITARY MANHOLE ON
EXISTING SANITARY MAIN
DETAIL

SAN-17

DATE: NOVEMBER 2022

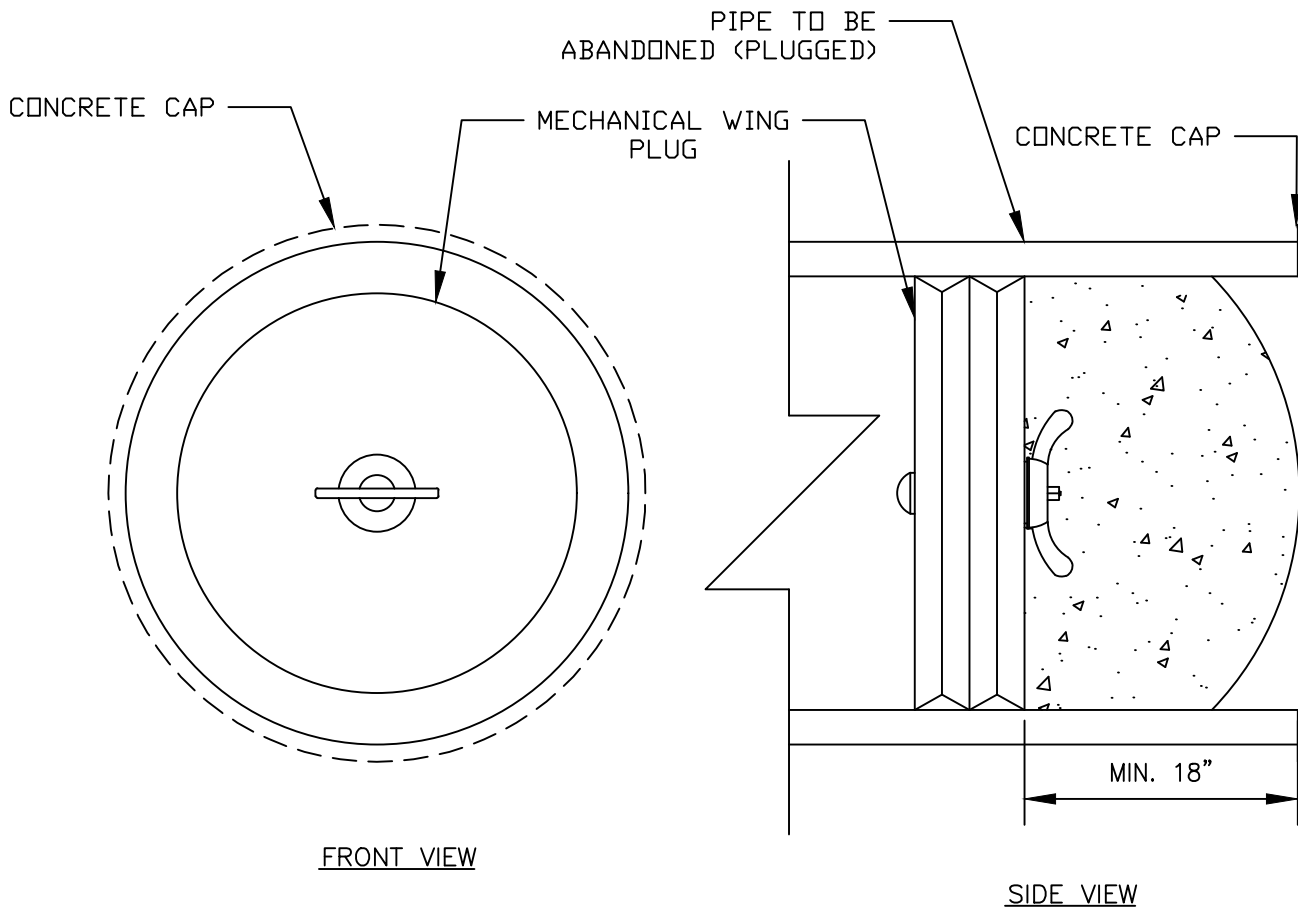

NOTE:

1. PIPES TO BE PLUGGED AND ABANDONED ARE TO BE CLEARED OF ANY DEBRIS PRIOR TO ABANDONMENT.
2. MECHANICAL WING PLUG TO BE INSERTED A MIN. OF 18 INCHES OR THE DIAMETER OF THE PIPE, WHICHEVER IS GREATER.
3. A CONCRETE CAP IS TO BE PLACED ON THE ABANDONED PIPE AFTER THE MECHANICAL WING PLUG HAS BEEN PROPERLY INSTALLED.
4. THE MECHANICAL WING PLUG MUST BE PRESSURE RATED GREATER THAN THE HEAD PRESSURE OF THE DEPTH OF THE PIPE.
5. BRICK AND MORTAR PLUGS WILL NOT BE ACCEPTABLE IN LIEU OF CONCRETE.

NOT TO SCALE

CITY OF JOLIET, ILLINOIS

PLUG PIPE DETAIL
SAN-18

DATE: NOVEMBER 2022

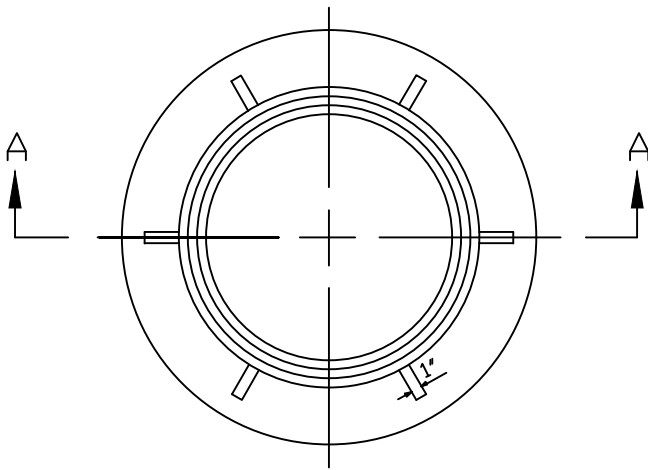

PLAN

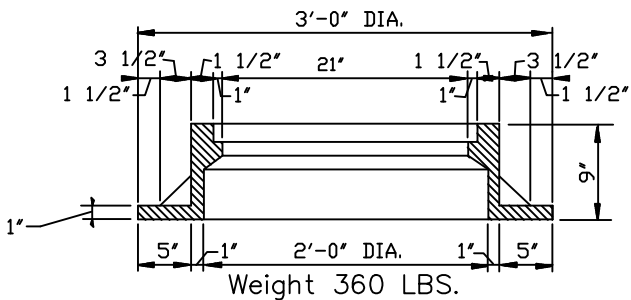

Weight 360 LBS.
Section A-A
Plan - Manhole
No Scale

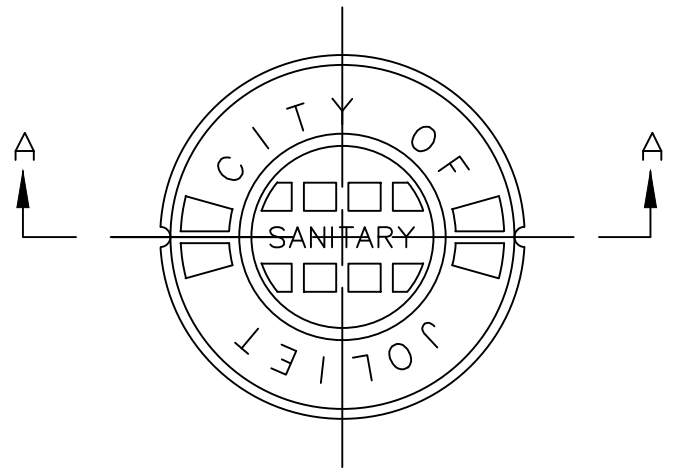

PLAN

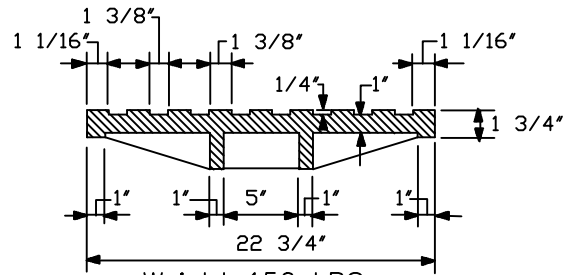

Weight 150 LBS.
Section A-A
Standard Closed Lid
No Scale

Sanitary Sewer:
East Jordan 1020 AGS cover and
1050Z1 frame W/Watertight Lid

NOT TO SCALE

CITY OF JOLIET, ILLINOIS
FRAME AND COVER CASTING
SAN-19

DATE: NOVEMBER 2022

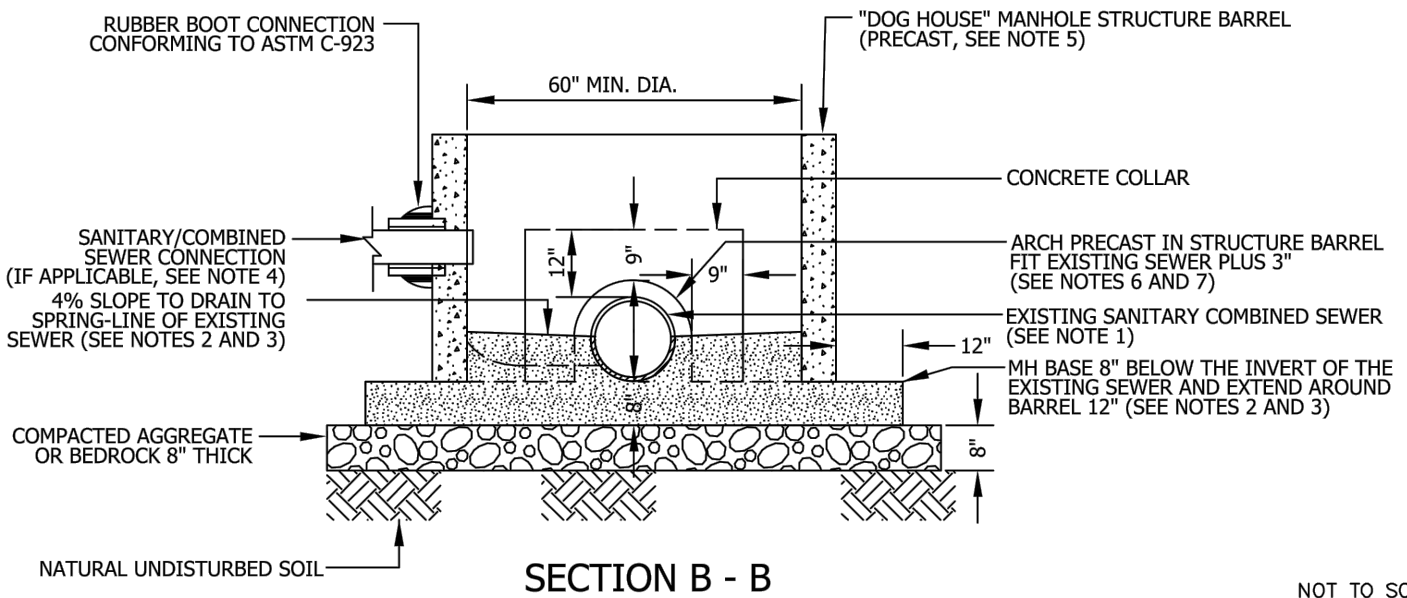
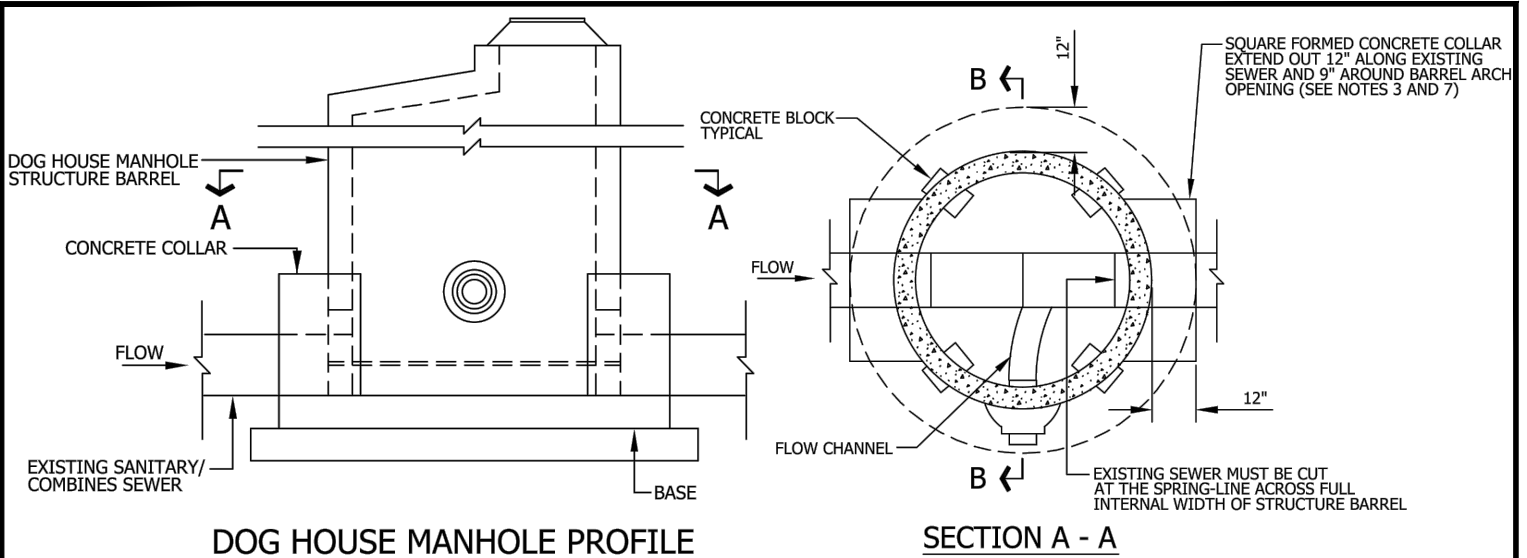

NOT TO SCALE

NOTES:

1. DOGHOUSE MANHOLES SHALL ONLY BE USED WHEN DIRECTED BY THE ENGINEER, TYPICALLY WHEN BYPASS OPERATIONS COULD CREATE RISK OF POSSIBLE BASEMENT BACKUPS.
2. EXISTING SANITARY SEWER MUST BE 15" DIAMETER OR LARGER FOR "DOGHOUSE" MANHOLE USE.
3. INTEGRAL POUR FOR BASE AND BENCH. (NO PRECAST BASE)
4. ALL POURED-IN-PLACE CONCRETE MUST BE 4000 PSI NON-SHRINK MIX.
5. EXTERNAL DROP CONNECTION MUST BE PROVIDED IF INVERT OF CONNECTING SEWER IS 24" OR MORE ABOVE THE INVERT OF THE OUTLET.
6. MANHOLE DIAMETER MINIMUM 60"-INCREASES BASED ON THE EXISTING SEWER DIAMETER.
7. CONCRETE BONDING AGENT MUST BE APPLIED TO ALL INTERFACES OF PRECAST CONCRETE SURFACES WITH POURED-IN-PLACE CONCRETE.
8. A CURVED INTERNAL ARCH FORM MUST BE USED DURING COLLAR CONCRETE FILL. NO BRICK, MORTAR, OR DEBRIS IS TO BE USED IN PLACE OF CONSOLIDATED CONCRETE.
9. DEBRIS MUST NOT BE ALLOWED TO ENTER THE SEWER SYSTEM AT ANY TIME DURING CONSTRUCTION.
10. ALL DIMENSIONS NOTED ARE MINIMUM ALLOWED.
11. THE STRUCTURE MUST NOT BE BACKFILLED FOR A MINIMUM OF 24 HOURS AFTER CONSTRUCTION.

NOT TO SCALE

CITY OF JOLIET, ILLINOIS

DOGHOUSE MANHOLE
SAN-20

DATE: NOVEMBER 2022

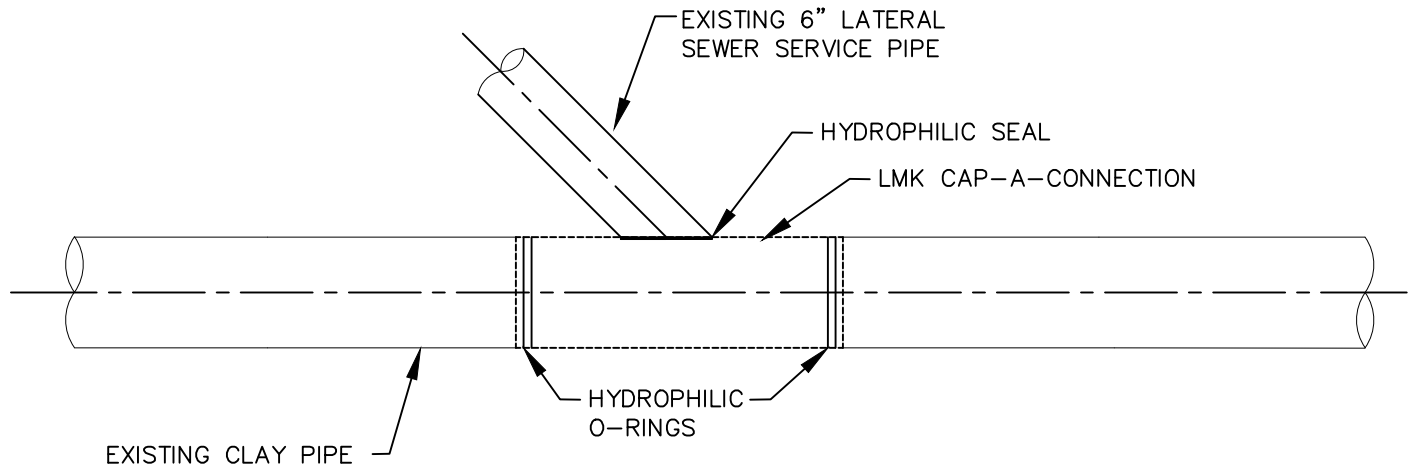

CAP-A-CONNECTION
LATERAL ABANDONMENT
(TRENCHLESS)

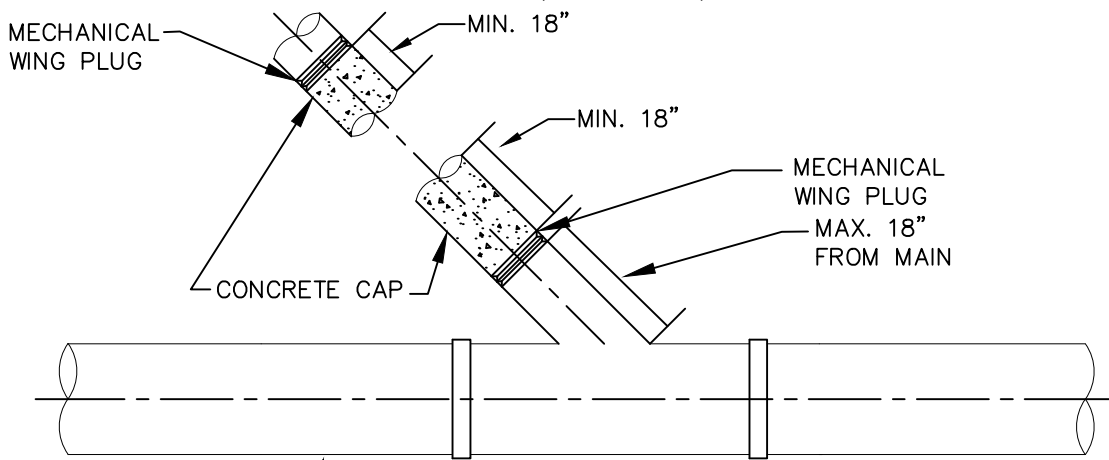

MECHANICAL PLUG
LATERAL ABANDONMENT
(NON-TRENCHLESS)

NOTE:

1. TRENCHLESS ABANDONMENT OF SANITARY LATERALS SHALL TAKE PRIORITY OVER NON-TRENCHLESS ABANDONMENT UNLESS AS DIRECTED BY THE ENGINEER.
2. ABANDONMENT OF THE SERVICE MUST OCCUR AT THE SANITARY MAIN UNLESS OTHERWISE APPROVED BY THE ENGINEER

NOT TO SCALE

CITY OF JOLIET, ILLINOIS

ABANDON SERVICE
CONNECTION – TRENCHLESS
& NON-TRENCHLESS
SAN-21
DATE: NOVEMBER 2022

PVC PIPE CORING SIZES

PIPE Ø (IN.)	CORE Ø (IN.)
8"	12"
10"	14"
12"	16"
15"	18"
18"	22"

MODIFY BENCHING,
IF NECESSARY,
BEFORE DRILLING HOLE

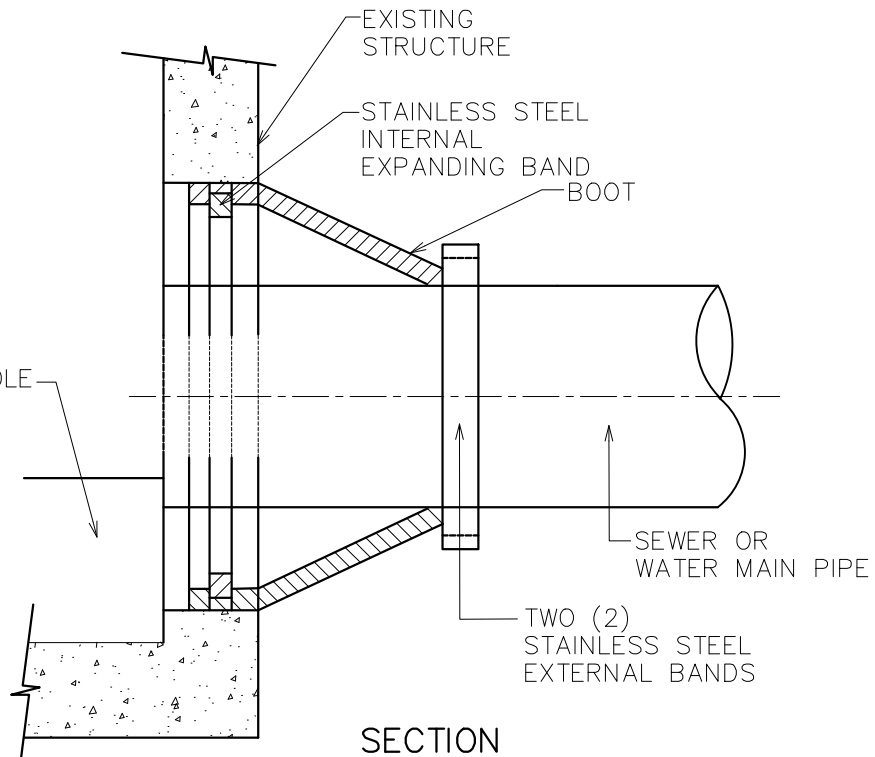

NOTES:

1. CORE-DRILL CIRCULAR OPENING IN STRUCTURE WALL OF DIAMETER TO FIT THE REQUIRED BOOT SIZE.
2. A-LOC OR KOR-N SEAL FLEXIBLE RUBBER BOOT SHALL BE USED FOR CONNECTIONS TO MANHOLES OR AS APPROVED BY CITY ENGINEERING SHALL BE USED FOR WATERTIGHT CONNECTION.
3. CUT, SHAPE AND SLOPE NEW INVERT CHANNEL IN THE EXISTING CONCRETE BENCH FOR SMOOTH FLOW FROM NEW CONNECTION.
4. CLEAN EXISTING STRUCTURE AND SEWER PIPE OF ANY DIRT, CONCRETE OR DEBRIS WHICH MAY ACCUMULATE DURING THE CONSTRUCTION PROCESS.
5. CONNECTION SHALL CONFORM TO ASTM C-923.

NOT TO SCALE

CITY OF JOLIET, ILLINOIS

CORE AND CONNECTION TO
EXISTING MANHOLE
SAN-22

DATE: NOVEMBER 2022

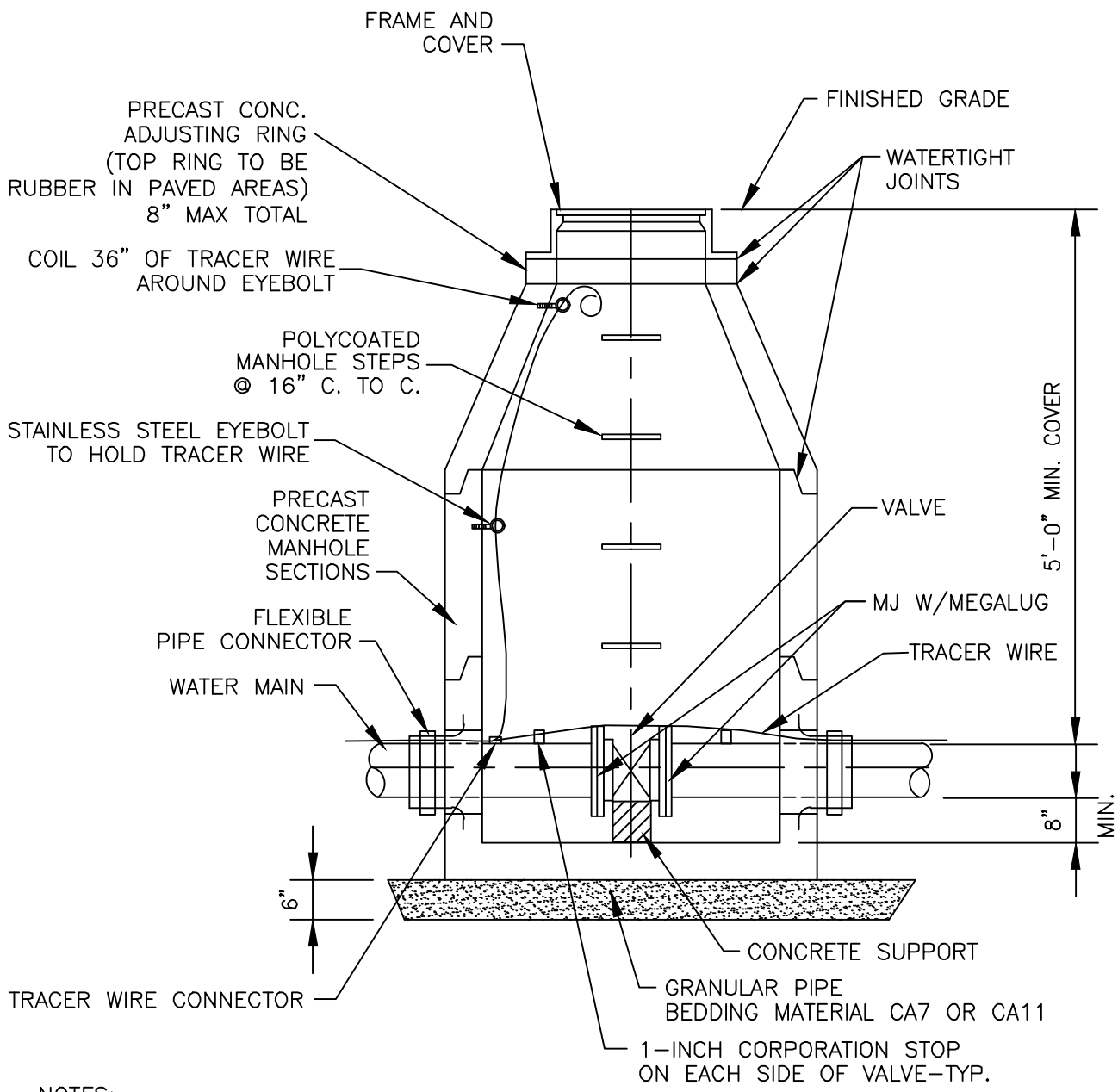

NOTES:

1. CONCENTRIC CONE REQUIRED FOR GATE VALVES, ECCENTRIC CONE REQUIRED FOR BUTTERFLY VALVES.
2. USE 4'-0" DIAMETER FOR WATER MAIN SIZES 4" THRU 10", 5'-0" FOR SIZES 12" OR GREATER
3. PROVIDE CAST IRON FRAME AND COVER WITH HEAVY DUTY LID, STAMPED WITH "CITY OF JOLIET" AND "WATER". EJ 1050Z1 OR NEENAH R170
4. ATTACH TRACER WIRE TO MAINTAIN MIN. 24" AWAY FROM STEPS

NOT TO SCALE

CITY OF JOLIET, ILLINOIS

WATER VALVE VAULT
DETAIL
WTR-01

DATE: NOVEMBER. 2022

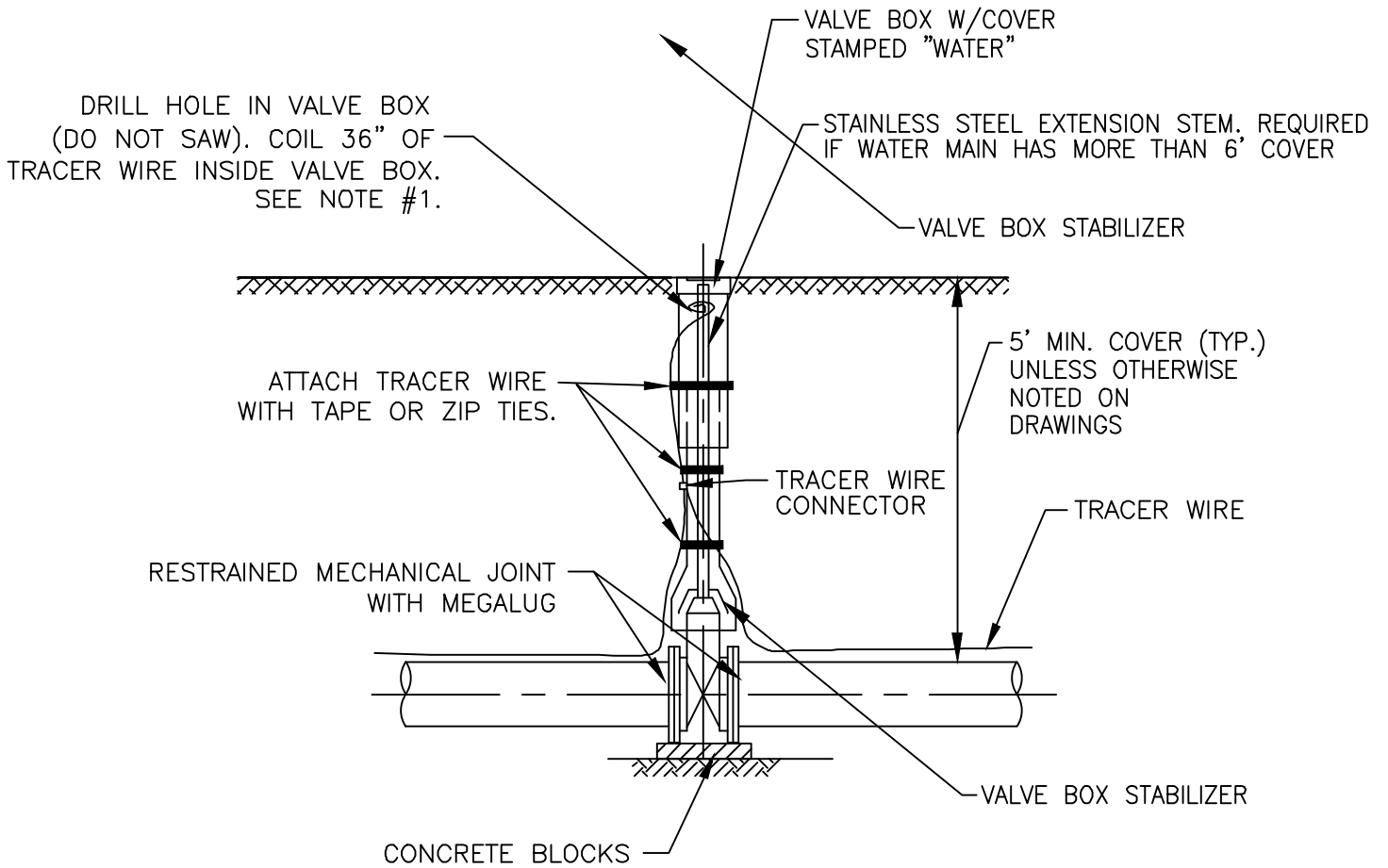

NOTES:

1. ATTACH TRACER WIRE TO OUTSIDE OF VALVE BOX USING TAPE OR ZIP TIES. DRILL $\frac{5}{8}$ " DIA. HOLE IN VALVE BOX 6" FROM TOP OF VALVE BOX.

NOT TO SCALE

CITY OF JOLIET, ILLINOIS

WATER VALVE BOX
DETAIL
WTR-02

DATE: NOVEMBER 2022

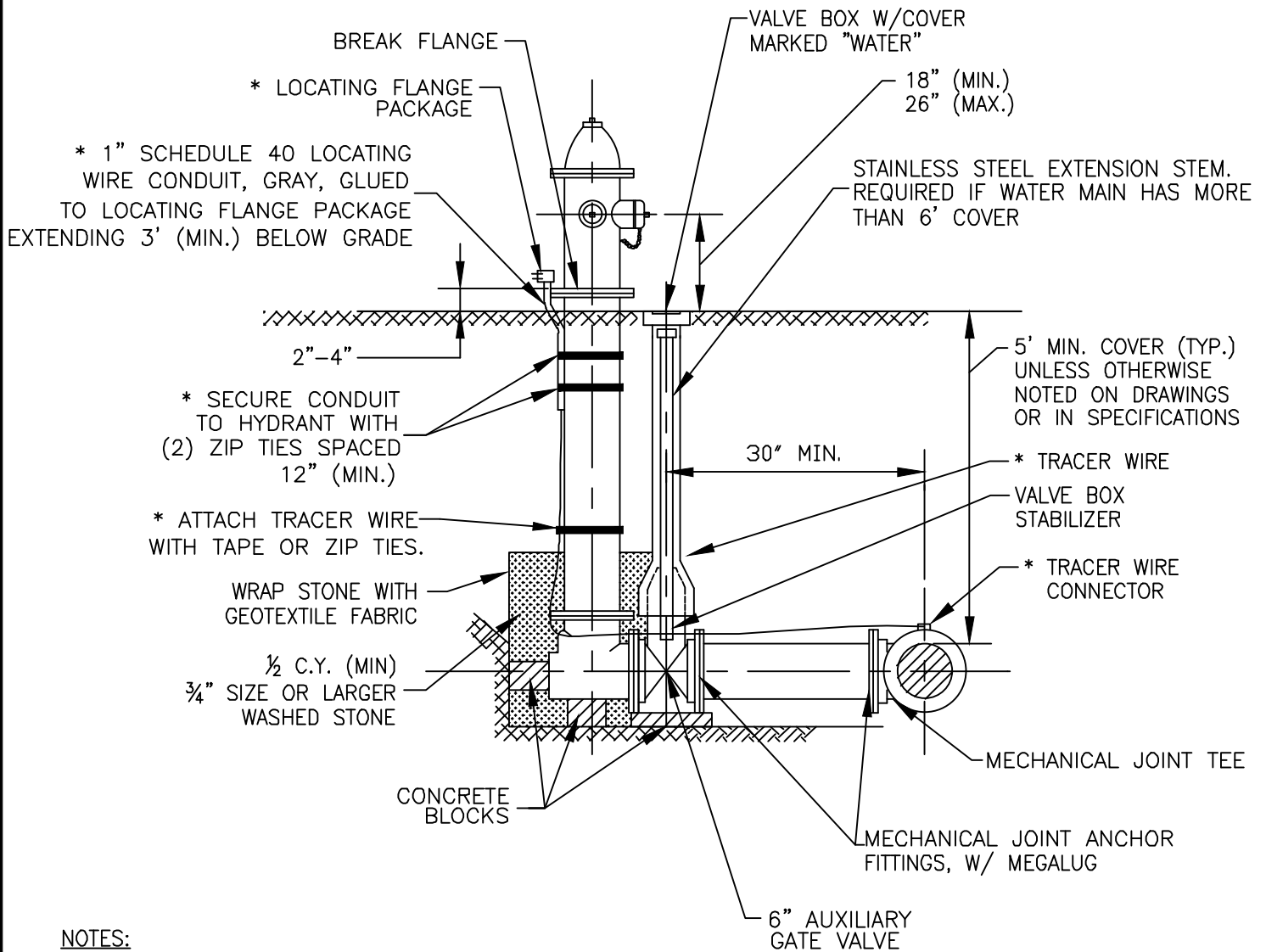

NOTES:

1. MUELLER CENTURION A423, CLOW MEDALLION OR E.J. 5BR250
(RED FOR MUNICIPAL TREATED WATER, GREEN FOR RAW WATER, YELLOW FOR PRIVATE HYDRANTS)
2. HYDRANTS SHALL BE LOCATED A MINIMUM OF 2 FEET BEHIND THE BACK OF CURB IN LOCATIONS SHOWN ON THE DRAWINGS
3. USE SWIVEL TEE AS CALLED OUT ON PLANS. 30" MINIMUM SEPARATION DOES NOT APPLY WHEN USING SWIVEL TEES.
- *4. LOCATING WIRE CONDUIT TO BE RIGID PIPE FORMED TO HYDRANT OR TOP 18" TO BE RIGID, WITH 12" (MAX.) FLEXIBLE CONDUIT BELOW, TRANSITIONING BACK TO RIGID CONDUIT.
- *5. LOCATING FLANGE PACKAGE TO BE RED COLOR COPPERHEAD INDUSTRIES COBRA HYDRANT PACKAGE PART # T1-FLPKG OR APPROVED EQUAL

* FOR PVC WATER MAIN INSTALLATION ONLY

NOT TO SCALE

CITY OF JOLIET, ILLINOIS

FIRE HYDRANT
DETAIL
WTR-03

DATE: NOVEMBER 2022

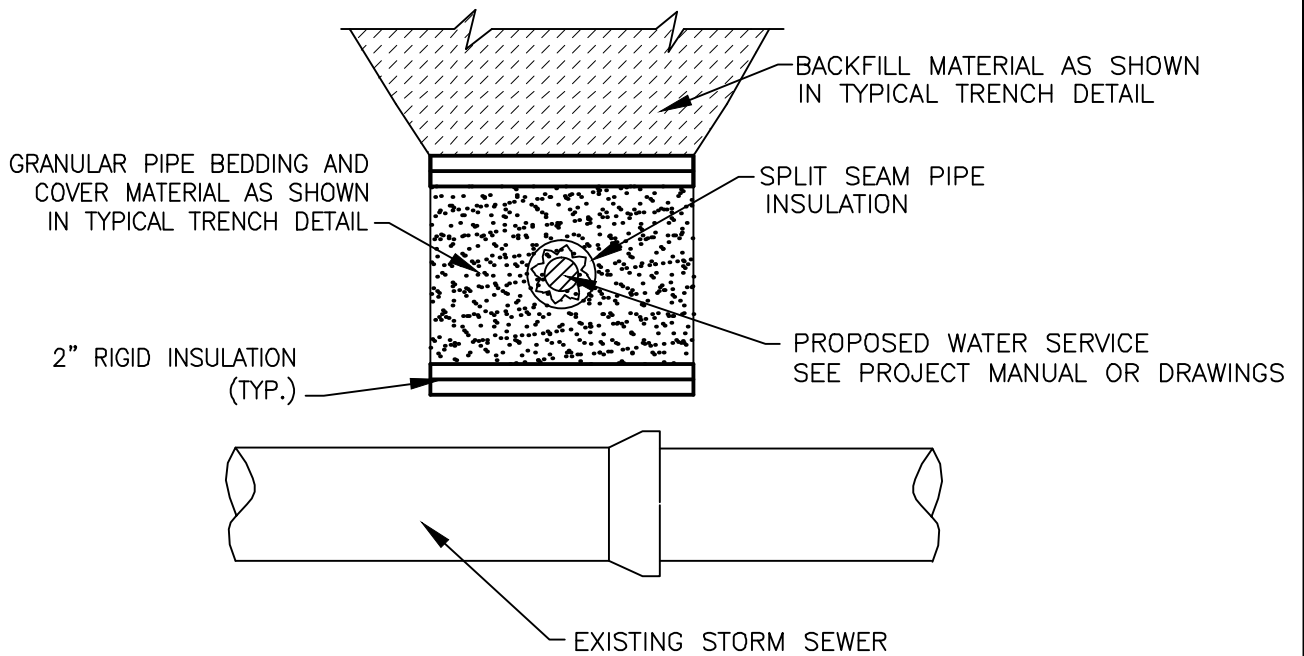

WATER SERVICE

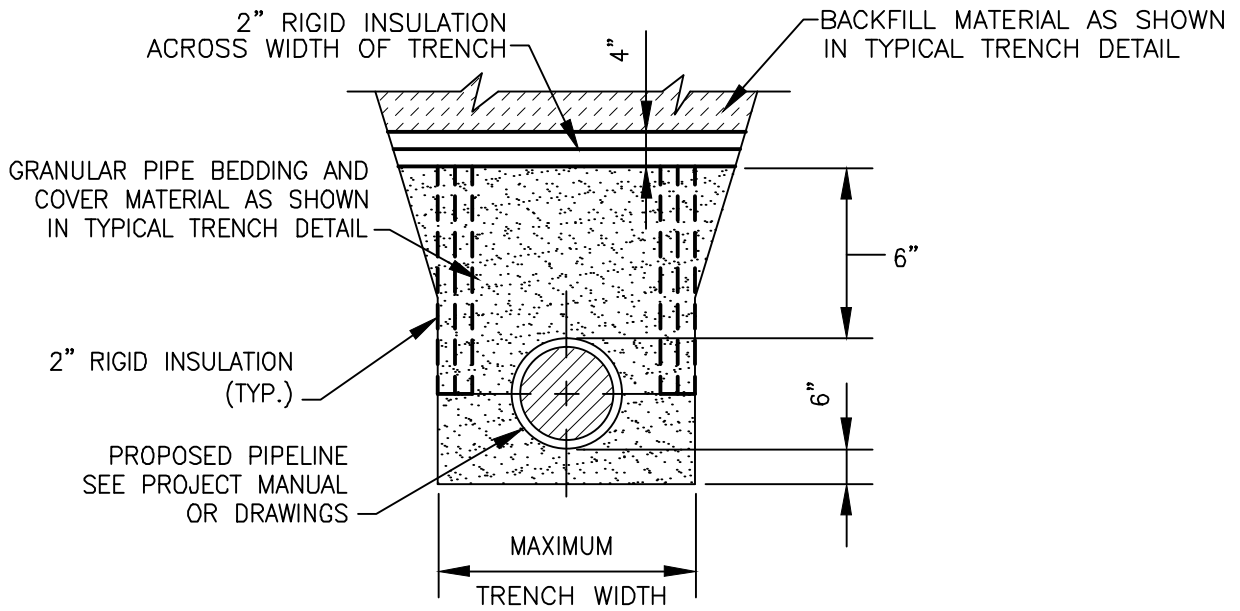

WATER MAIN

NOTES:

1. TO BE USED WHEN WATER MAIN AND / OR WATER SERVICE BURY DEPTH IS < 4' OR WHEN WATER SERVICE CROSSES ABOVE STORM SEWER.

NOT TO SCALE

CITY OF JOLIET, ILLINOIS

PIPE INSULATION
DETAIL
WTR-04

DATE: OCT. 2017

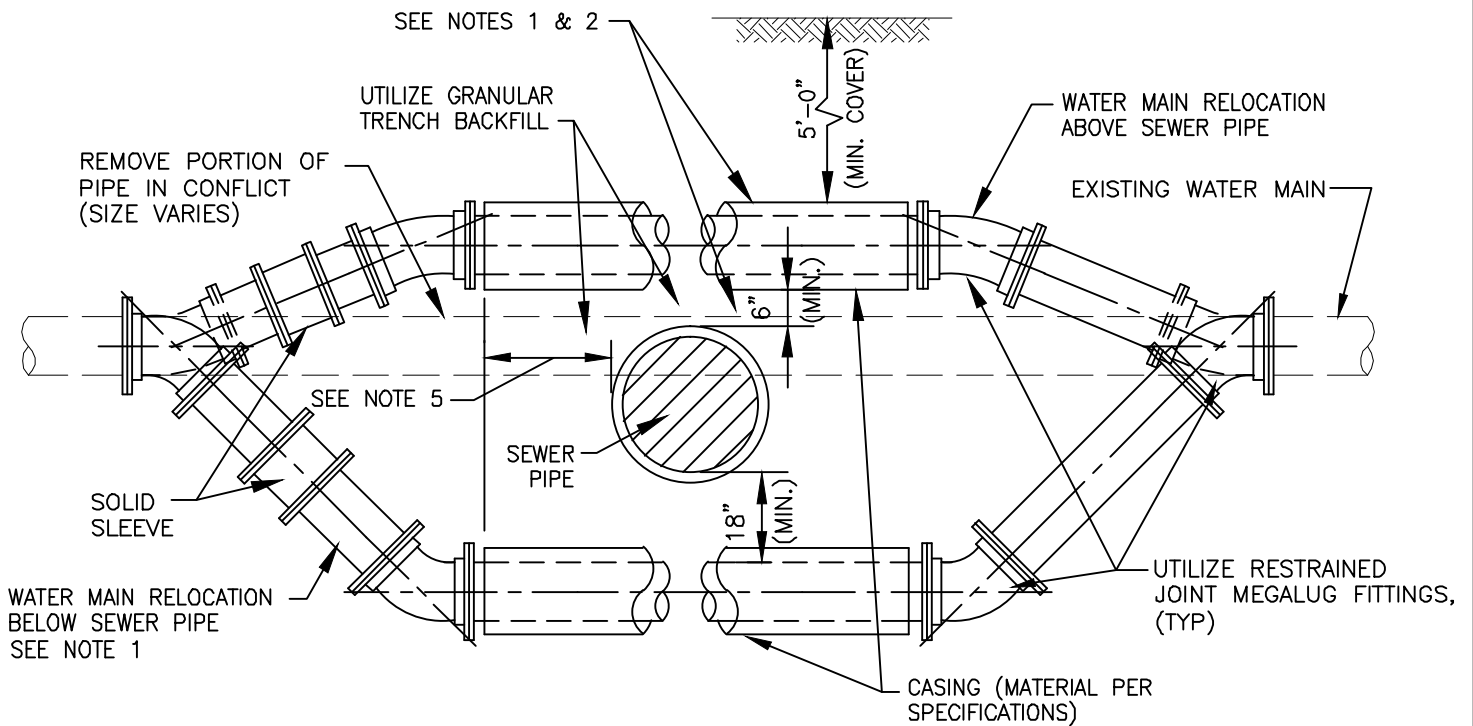

- NOTES:
1. ONLY TO BE USED IF WATER MAIN CANNOT CROSS ABOVE PROPOSED SEWER AND MAINTAIN THE REQUIRED 18" OF SEPARATION AS SHOWN ON DRAWING, OR APPROVED BY ENGINEER IN FIELD.
 2. WHEN WATER MAIN CROSSES ABOVE SEWER AND MAINTAINS THE REQUIRED 18" OF SEPARATION, THE CASING PIPE IS NOT REQUIRED.
 3. WATER MAIN RELOCATIONS ARE SUBJECT TO INSPECTION AT NORMAL SYSTEM PRESSURE BEFORE BURIAL.
 4. USE ONLY 45 DEGREE BENDS UNLESS OTHERWISE PERMITTED BY THE ENGINEER.
 5. CASING MUST EXTEND A MINIMUM OF 10 FEET BEYOND OUTSIDE EDGE OF SEWER PIPE – ON BOTH SIDES OF SEWER.

NOT TO SCALE

CITY OF JOLIET, ILLINOIS

WATER MAIN RELOCATION
DETAIL
WTR-05

DATE: OCT. 2017

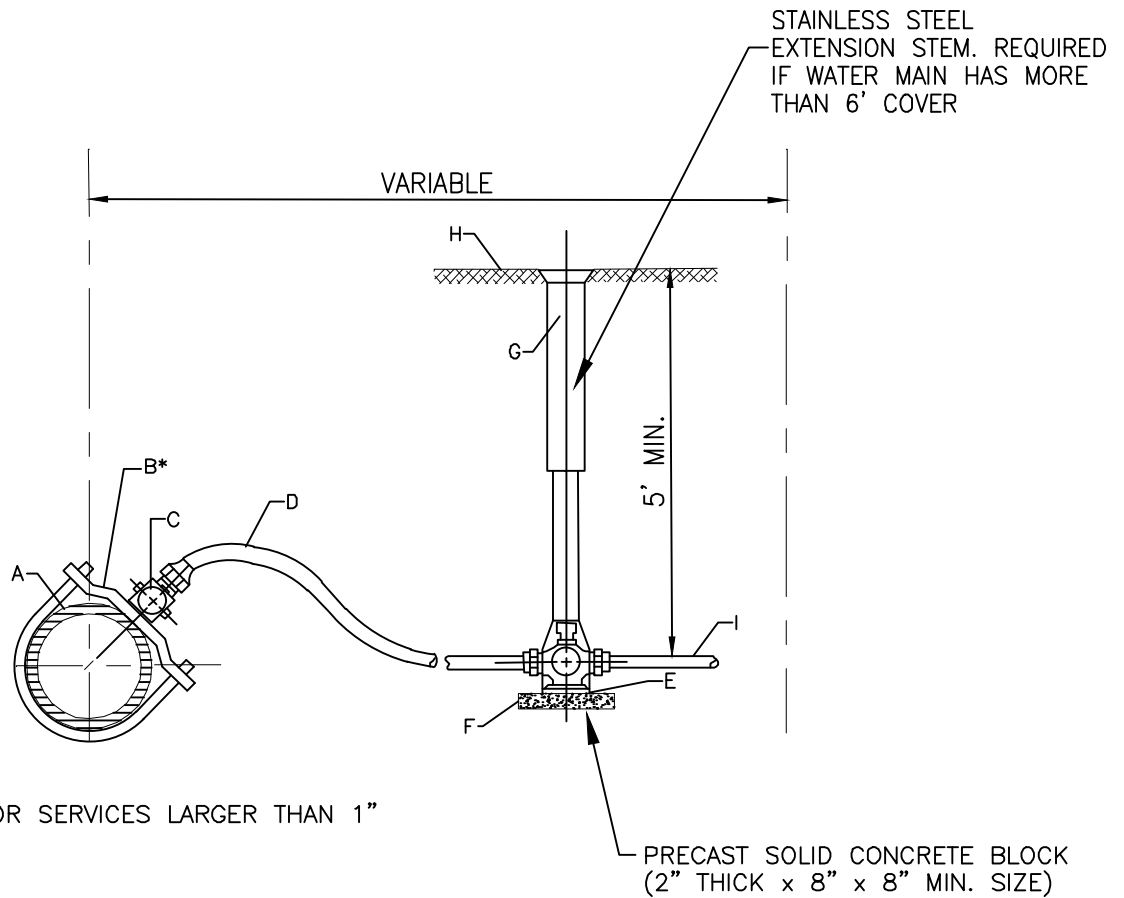

*REQUIRED FOR SERVICES LARGER THAN 1"

CONSTRUCTION NOTES

- A. WATER MAIN
- B. DUCTILE IRON, EPOXY COATED BODIES WITH DOUBLE ALLOY STEEL STRAPS AND DOUBLE BOLTS (FOUR BOLTS TOTAL). MUELLER DR2A SERIES OR EQUAL
- C. CORPORATION STOP, A.Y. MCDONALD 74701 BQ
- D. SERVICE PIPE, SEAMLESS SOFT TEMPERED COPPER TYPE – TYPE "K" 1" OR LARGER
- E. CURB STOP, A.Y. MCDONALD 76104Q
- F. CONCRETE BRICK SUPPORT
- G. TYLER 6500 WITH BBAF VALVE BOX STABILIZER OR APPROVED EQUAL
- H. FINISHED GRADE
- I. CONNECT TO EXISTING SERVICE, PROVIDE ADAPTERS AS REQUIRED

NOTE: FOR 1 1/2" OR 2" SERVICE, ADD ENLARGED BASE FOR SERVICE BOX.

NOT TO SCALE

CITY OF JOLIET, ILLINOIS

WATER SERVICE
CONNECTION DETAIL
WTR-06

DATE: OCT. 2017

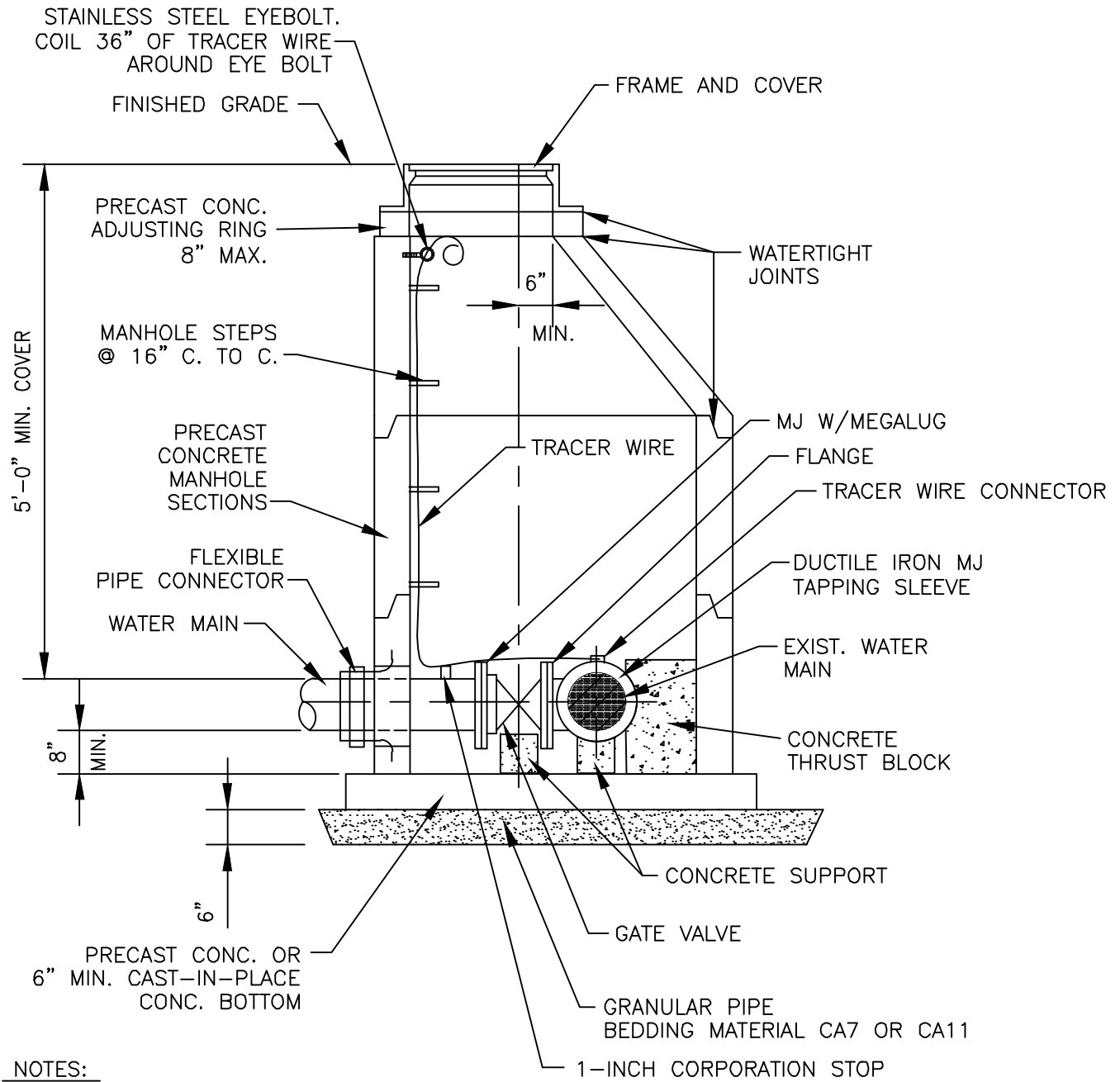

NOTES:

1. ECCENTRIC CONE REQUIRED
2. USE 4'-0" DIAMETER FOR WATER MAIN SIZES 4" THRU 8", USE 5'-0" DIAMETER FOR WATER MAIN SIZES 10" THRU 14", USE 6'-0" DIAMETER (OR LARGER PER DESIGNER) FOR WATER MAIN SIZES 16" OR GREATER.
3. PROVIDE CAST IRON FRAME AND COVER WITH HEAVY DUTY LID, STAMPED WITH "CITY OF JOLIET" AND "WATER". EJ 1050Z1
4. ATTACH TRACER WIRE TO MAINTAIN MIN. 24" AWAY FROM STEPS.

NOT TO SCALE

CITY OF JOLIET, ILLINOIS

PRESSURE CONNECTION
DETAIL
WTR-07

DATE: NOVEMBER 2022

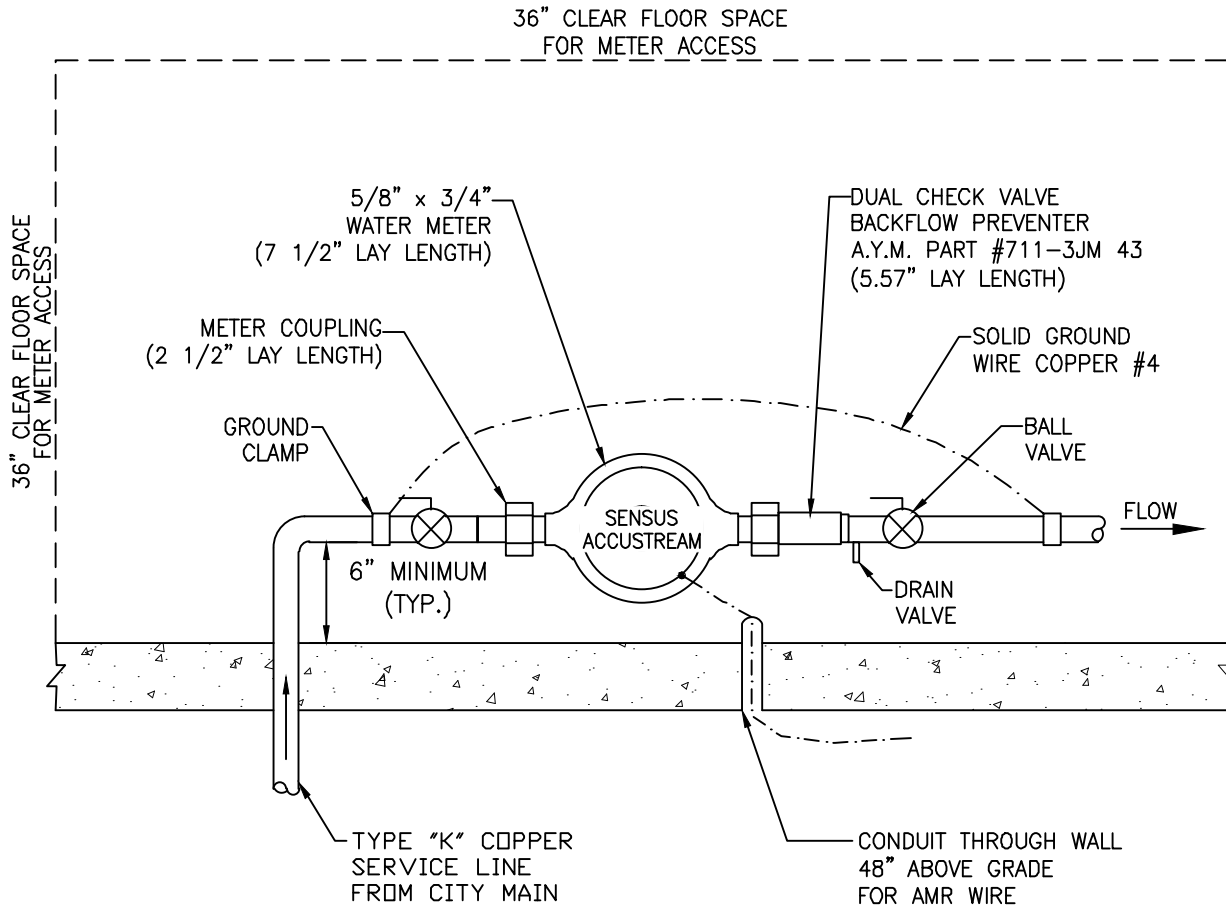

WATER METER
PLAN VIEW
N.T.S.

1. CENTER LINE OF PIPE AT METER TO BE 18" TO 48" ABOVE FLOOR.
2. AMR CONDUIT TO BE 48" ABOVE GROUND LEVEL. LEAVE MINIMUM OF 12" WIRE OUTSIDE HOLE.
3. EXPANSION TANK REQUIRED AFTER DUAL CHECK VALVE BETWEEN SHUT OFF VALVE TO HOT WATER HEATER AND HOT WATER HEATER.
4. FOR NEW CONSTRUCTION, METER COUPLING, DUAL CHECK, AND AMR WIRE PURCHASED FROM CITY.
5. PLUMBER TO INSTALL COPPER PIPING THROUGH ENTIRE METER/VALVE AREA BEFORE CUTTING OUT SECTION FOR METER AND CHECK VALVE.
6. TO BE USED FOR NEW CONSTRUCTION OR AS INSTRUCTED.

NOT TO SCALE

CITY OF JOLIET, ILLINOIS

WATER METER DETAIL
5/8" X 3/4"

WTR-08
DATE: OCT. 2017

DUCTILE IRON-RESTRAINT JOINT TYPE PIPE LENGTH (FEET)

FITTING TYPE	DIAMETER (IN)					
	4"	6"	8"	10"	12"	16"
HORIZONTAL BEND						
11.25°	5	5	5	5	5	5
22.5°	5	5	5	5	10	10
45°	5	10	10	10	15	15
90°	15	20	20	25	30	40
VERTICAL BEND						
45°	20	25	35	40	45	60
TEE	5	5	5	5	5	5
VALVE (OPERATING PRESSURE)	20	30	35	45	50	65
VALVE (TESTING PRESSURE)	40	60	75	90	105	135
REDUCER						
6" NOMINAL PIPE	30	-	-	-	-	-
8" NOMINAL PIPE	55	35	-	-	-	-
10" NOMINAL PIPE	75	55	30	-	-	-
12" NOMINAL PIPE	90	80	55	35	-	-
16" NOMINAL PIPE	125	115	100	80	60	-

NOTE:
 RJT LENGTHS MAY VARY DEPENDING ON
 SITE CONDITIONS. LENGTHS SHOWN ARE
 MINIMUM PER 5' BURRY DEPTH OF WATER
 MAIN AND, AGGREGATE PIPE BACKFILL.

NOT TO SCALE

CITY OF JOLIET, ILLINOIS

POLYWRAPPED DI RJT
 DETAIL

WTR-09

DATE: NOVEMBER 2022

PVC-RESTRAINT JOINT TYPE PIPE LENGTH (FEET)

FITTING TYPE	DIAMETER (IN)					
	4"	6"	8"	10"	12"	16"
HORIZONTAL BEND						
11.25'	5	5	5	5	5	5
22.5'	5	5	5	5	5	10
45'	5	10	10	10	15	15
90'	10	15	15	20	25	35
VERTICAL BEND						
45'	15	15	20	25	30	40
TEE	5	5	5	5	5	5
VALVE (OPERATING PRESSURE)	15	20	25	30	35	45
VALVE (TESTING PRESSURE)	30	40	50	60	70	90
REDUCER						
6" NOMINAL PIPE	20	-	-	-	-	-
8" NOMINAL PIPE	35	20	-	-	-	-
10" NOMINAL PIPE	50	35	20	-	-	-
12" NOMINAL PIPE	60	50	40	20	-	-
16" NOMINAL PIPE	80	75	65	55	40	-

NOTE:

RJT LENGTHS MAY VARY DEPENDING ON SITE CONDITIONS. LENGTHS SHOWN ARE MINIMUM PER 5' BURRY DEPTH OF WATER MAIN AND, AGGREGATE PIPE BACKFILL.

NOT TO SCALE

CITY OF JOLIET, ILLINOIS

PVC RJT DETAIL
WTR-10

DATE: NOVEMBER 2022

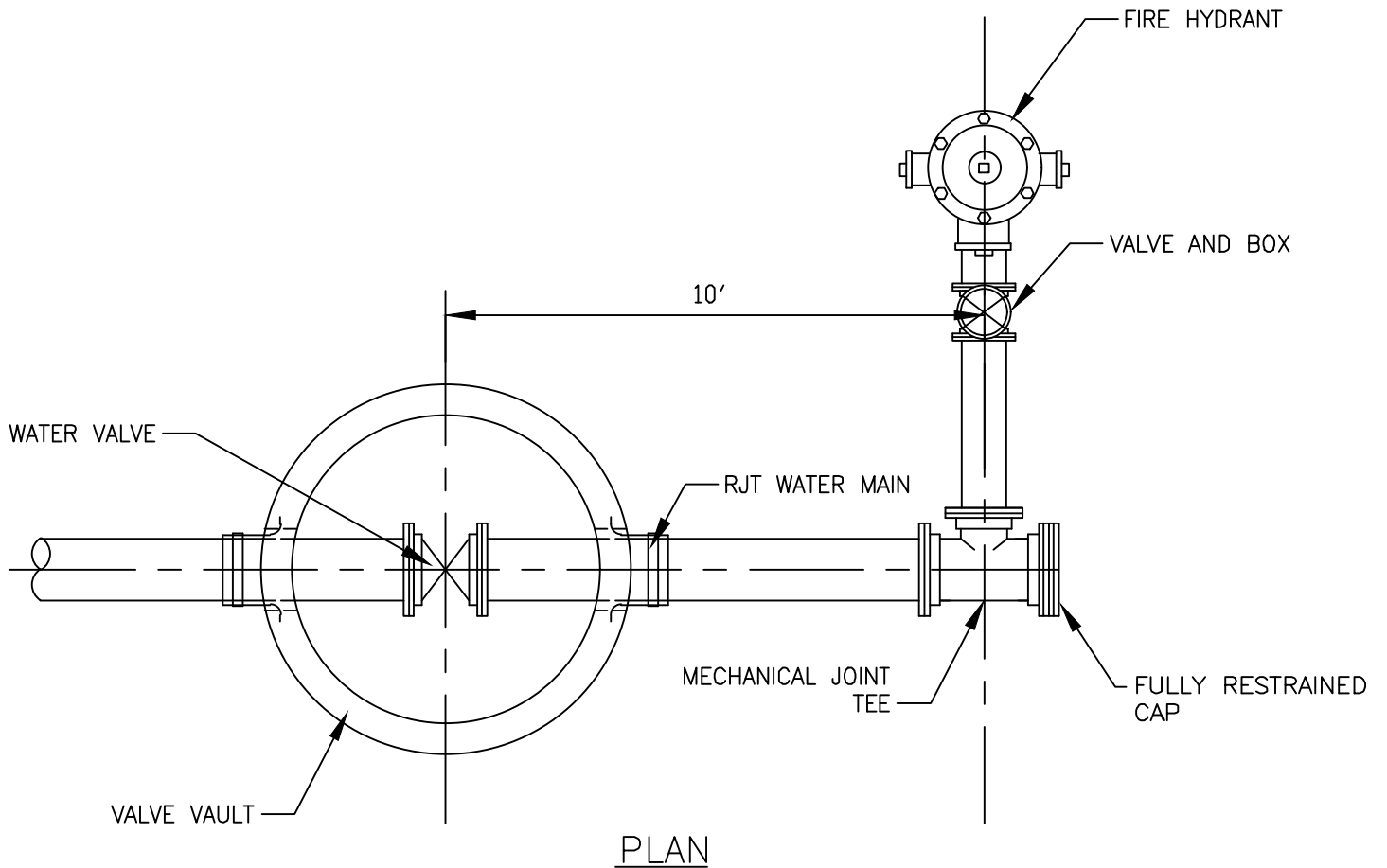

NOT TO SCALE

CITY OF JOLIET, ILLINOIS

WATER MAIN TERMINATION
DETAIL
WTR-12

DATE: NOVEMBER 2022

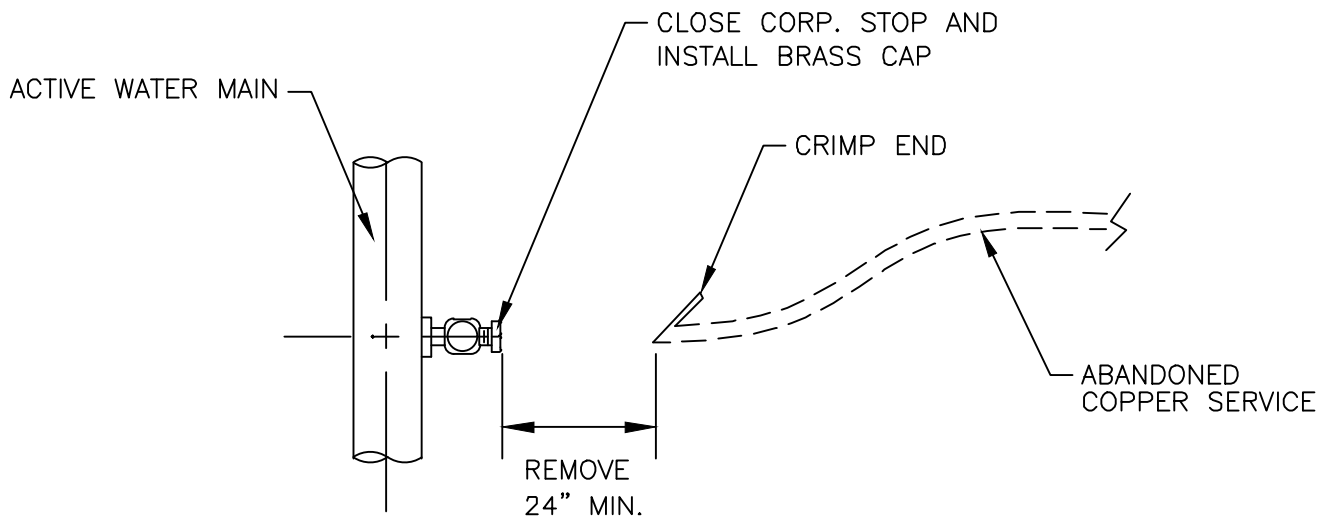

NOT TO SCALE

CITY OF JOLIET, ILLINOIS
WATER SERVICE ABANDONMENT
COPPER PIPE
DETAIL
WTR-13
DATE: NOVEMBER 2022

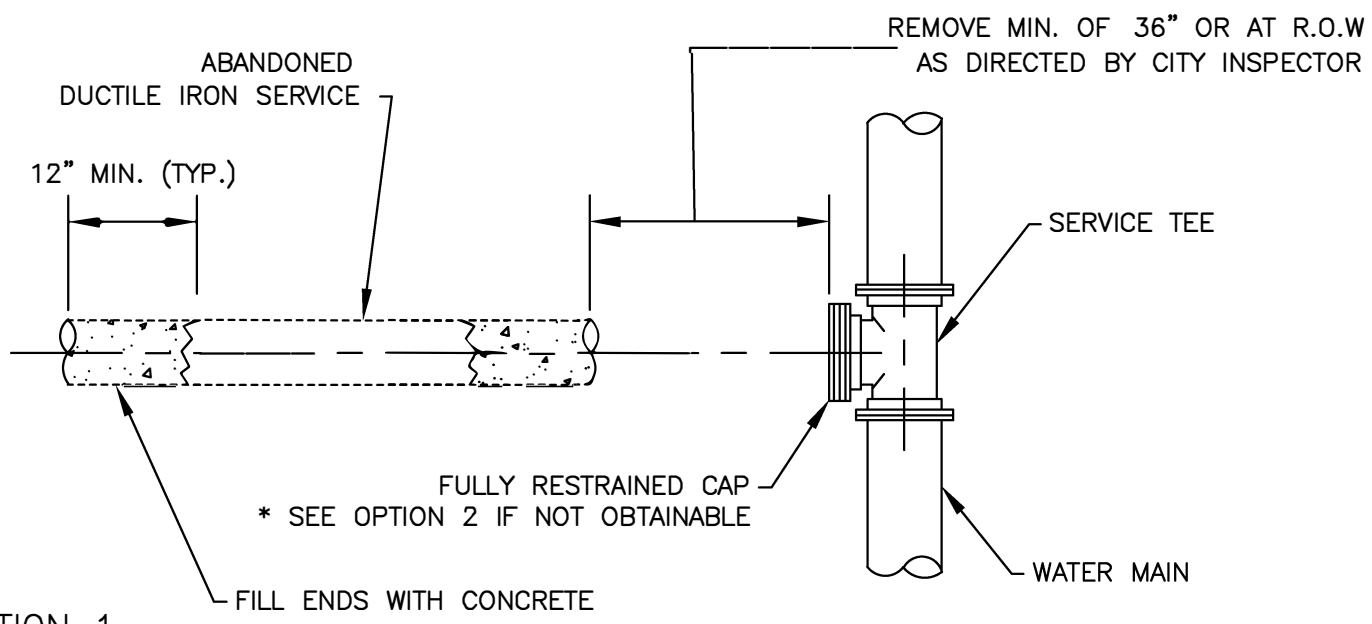

OPTION 1

OPTION 2

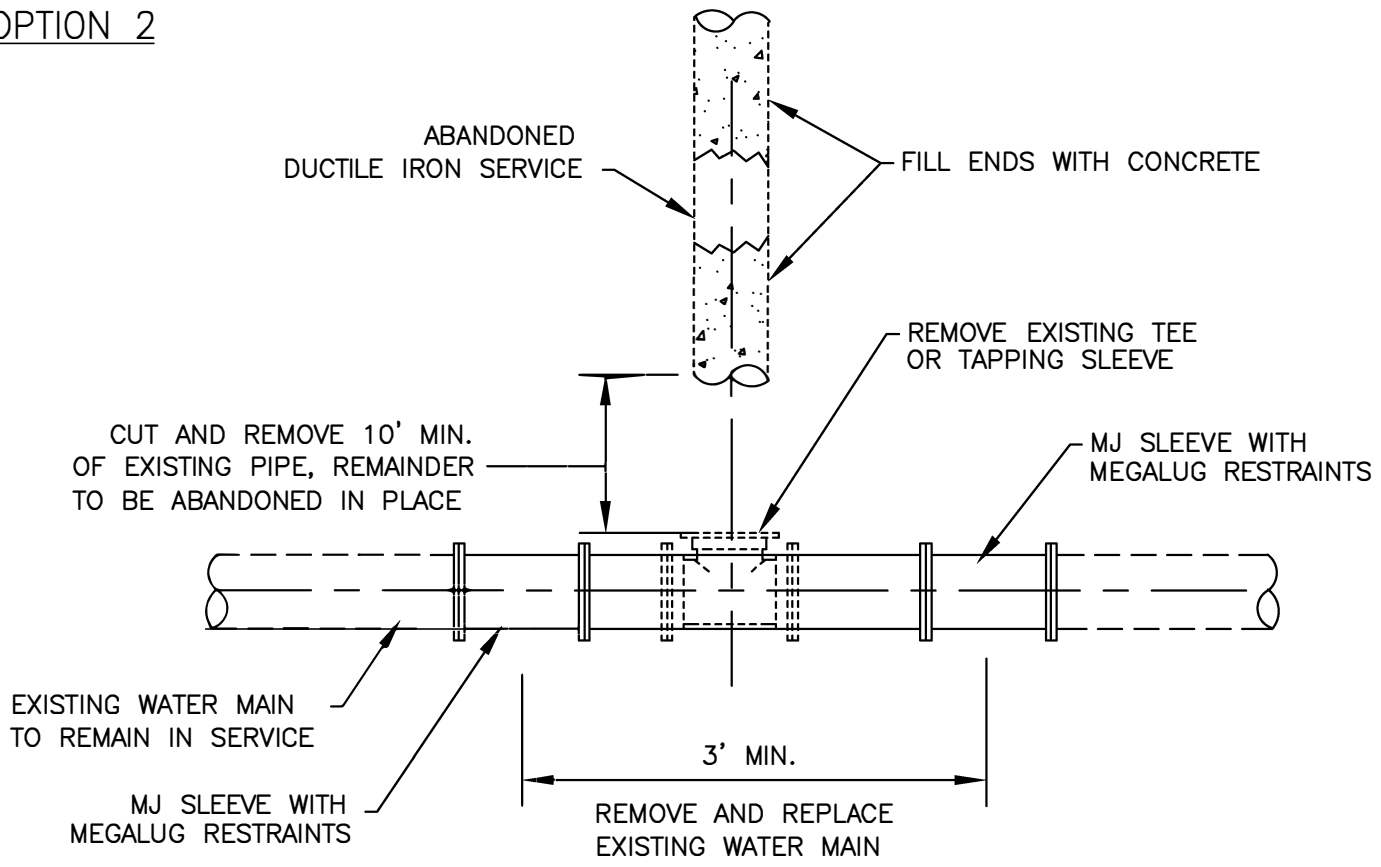

NOT TO SCALE

NOTES:

1. IF EXISTING SERVICE TEE CANNOT BE PROPERLY CAPPED AS SHOWN IN OPTION 1, TEE WILL BE REMOVED AND WATER MAIN REPLACED AS INDICATED BY OPTION 2.

CITY OF JOLIET, ILLINOIS

WATER SERVICE ABANDONMENT
DUCTILE IRON PIPE
DETAIL
WTR-14
DATE: NOVEMBER 2022

APPENDIX C

Lift Station Design Requirements

City of Joliet, IL

Standard Design for Duplex Submersible Pumping Stations

Updated: September 3, 2020

Pump Features	
1a Pump type (<50 HP)	duplex submersible vortex
1b Max. pump speed allowable?	3600 RPM
1c Approved Pump manufacturers:	Grundfos, Flygt Econoline, Hydromatic, Barnes or Wilo
2a Pump type (>50 HP)	duplex submersible vortex
2b Max. pump speed allowable?	1200 RPM
2c Approved Pump manufacturers:	Wilo ,Flygt or Vaughan
3 Check Valves	Oil Cushioned
4a Isolation Valves	Plug Valves
4b Provide isolation valve upstream of check valve?	Yes
4c Actuator on isolation valve	Handwheel
4d Force main isolation valve after valve vault?	Yes
5a Size of quick disconnect for portable pump	Plain End - Review with Operations Superintendent
5b Provide a "Porta-Con" connection in valve vault slab?	Not unless required by IEPA
5c Provide a "Porta-Con" connection in wetwell?	Not unless required by IEPA
6 Plug valve manufacturers	DeZurik or Valmatic
7 Flanged Piping requirements	Class 53 DI w/ SS bolts

Electrical + Control System Decisions	
1a Wetwell level sensing	Radar Sensor, Vega PULS WL61
1b Stilling well for level sensor?	No
2 Control Panel type	NEMA 4x stainless
3 Phase Seq. Monitor/Relays? (undervoltage, phase loss)	Yes
4 Motor High Temperature Alarm	local visual in panel (req'd)
5 Seal Failure Alarm	local visual inside panel
6 High Water Alarm	local visual in panel (req'd)
7a Proof of flow required? (limit switch on check valves to detect when stuck open)	No (can be a nuisance issue)
7b Use a common alarm instead of individual alarms ?	No
8a Standby Generator?	Yes - Fixed natural gas preferred

8b	If fixed, locate inside building?	No - metal housing
8c	Generator Manufacturers	Caterpillar, Cummins or MTU
8d	For a fixed generator, type of transfer switch	Automatic
9	Pump speed control ?	VFDs for pumps greater than 50 HP
10a	What VFD mfgrs to specify?	ABB, Danfoss, or Allen Bradley
10b	Bypass Contactor on VFD?	Yes, on at least one pump when pumps are greater than 50 HP
10c	Air conditioner in VFD cabinet?	Yes
11	SCADA	Micrologix 1400, must specify City's preferred integrator
12	PLC manufacturers	Allen Bradley
13	Flow measurement	Mag Meter (ABB or Siemens)
14	Ground fault protection (req'd) ...	Equipment + personnel
15	Surge/lightning arrestor	Yes
16a	Pressure gauges on force main	Yes - diaphragm seal type
16b	Continuous FM pressure monitoring + alarming?	Yes for pumps greater than 50 HP
17	Locate controls & elec in air conditioned NEMA 4X stainless steel outdoor panels	Yes, for standard duplex submersible pump station.
18	Locate controls & elec in NEMA 1 enclosures in a single package building	TBD on case by case basis for larger stations

Accessories		
1	Method to remove pumps	Crane Truck
2	Lifting cable	stainless steel chain-316
3	Guide rails	stainless steel-316
4a	Access Hatch locking device	Hasp in floor
4b	Access Hatch load strength	H-20
5	Fall protection for hatch	safety grate
6	Debris basket	No
7a	Wetwell & FM Discharge MH (New)	Polymer Concrete Structure, US Composite Pipe
7b	Wetwell & FM Discharge MH (Existing)	Sherwin Williams DuraPlate 6100 or Raven 405
8	Discharge Piping	Link Seal required where pipe exits wet well
9	Wetwell Backfill	For wetwells deeper than 15 feet, CLSM is required for backfill up to 10 feet below grade.
10	Driveway type	asphalt
11	Fencing	TBD on case by case basis
12	Provide sump pumps in valve vault + mag meter	Yes - sump only, City to provide pump

	vault?	
13	Provide permanent ventilation in valve vault/meter vault?	Yes - fixed
14	Conc filled Bollards at station+valve vault?	Yes, painted yellow
15	Intrusion Alarms?	No
16	Site Lighting?	Depends on Location. If Residential, no. If Industrial/Commercial provide pole mount, photocell lighting
17	Sampler Required	No
18	Need to provide potable water service into the site?	No
19	Odor Control	TBD on case by case basis. System shall be non-passive, forced air

APPENDIX D

General Notes

CITY OF JOLIET WATER & SEWER SYSTEM GENERAL NOTES

1. CONTRACTOR TO NOTIFY THE DEPARTMENT OF PUBLIC UTILITIES 48 HOURS IN ADVANCE OF START OF CONSTRUCTION AT 815-724-4220.
2. VERIFY LOCATION, SIZE, AND DEPTH OF ALL EXISTING UTILITIES PRIOR TO CONSTRUCTION. THE LOCATIONS OF EXISTING UTILITIES AS SHOWN ON THE DRAWINGS HAVE BEEN DETERMINED FROM THE BEST AVAILABLE INFORMATION AND IS GIVEN FOR THE CONVENIENCE OF THE CONTRACTOR. THE ENGINEER AND OWNER DO NOT ASSUME RESPONSIBILITY FOR THE ACCURACY OF THE LOCATION SHOWN. IT SHALL BE THE CONTRACTOR'S RESPONSIBILITY TO CONTACT ALL UTILITY COMPANIES AND LOCATE UTILITIES PRIOR TO ANY WORK.
3. WHEREVER OBSTRUCTIONS NOT SHOWN ON THE DRAWINGS ARE ENCOUNTERED DURING THE PROGRESS OF THE WORK AND INTERFERE TO SUCH AN EXTENT THAT ALTERATIONS TO THE DRAWINGS ARE REQUIRED, THE ENGINEER SHALL BE NOTIFIED PRIOR TO ANY CHANGES.
4. HORIZONTAL AND VERTICAL SEPARATION OF WATER MAINS AND SEWER LINES SHALL BE DONE IN ACCORDANCE WITH THE LATEST EDITION OF THE "STANDARD SPECIFICATION FOR WATER AND SEWER CONSTRUCTION IN ILLINOIS".
5. PROVIDE PROPERTY OWNERS ADVANCE NOTICE OF CONSTRUCTION ACTIVITIES THAT WILL RESTRICT THE USE OF THEIR DRIVEWAYS.
6. DO NOT STORE BEDDING AND BACKFILL MATERIALS, PIPES, FITTINGS, VAULTS, OR OTHER MATERIALS IN AREAS THAT WILL OBSTRUCT SIGHT LINES FOR STREETS AND DRIVEWAYS.
7. ALL PROPOSED UTILITIES UNDER AND WITHIN 2' OF PAVEMENT OR SIDEWALK SHALL BE BACKFILLED WITH TRENCH BACKFILL WHICH SHALL BE CRUSHED STONE, GRADATION CA 6 OR CA 7.
8. ALL MATERIALS SHALL BE IN ACCORDANCE WITH THE CITY OF JOLIET DEPARTMENT OF PUBLIC UTILITIES APPROVED MATERIALS LIST, LATEST EDITION

9. INSTALL NEW WATER MAIN WITH A MINIMUM OF 5' COVER BELOW EXISTING OR PROPOSED GROUND SURFACE UNLESS GREATER DEPTH IS REQUIRED TO AVOID EXISTING UTILITIES OR WHERE INDICATED ON THE DRAWINGS.
10. PROVIDE 48 HOURS ADVANCE NOTICE TO THE CITY WHEN CONNECTION TO AN EXISTING WATER MAIN WILL BE MADE. COORDINATE SHUTDOWN OF EXISTING WATER MAINS WHEN REQUIRED WITH THE CITY. SCHEDULE THE WORK TO MINIMIZE THE NUMBER AND LENGTH OF SHUTDOWNS. PROVIDE WRITTEN NOTIFICATION OF SHUTDOWNS TO WATER USERS AFFECTED 24 HOURS IN ADVANCE.
11. NOTIFY THE CITY'S PUBLIC UTILITIES DEPARTMENT IMMEDIATELY IF EXISTING LEAD WATER SERVICES ARE DISCOVERED.

LOCATE PRESSURE CONNECTIONS, IF INDICATED ON THE DRAWINGS OR WHEN DIRECTED BY THE ENGINEER, A MINIMUM OF 2' FROM ANY EXISTING REPAIR SLEEVES OR PIPE JOINTS.
12. PROVIDE A TEMPORARY COVERING OVER ALL NEW FIRE HYDRANTS UNTIL ALL NEW WATER MAINS ARE PUT INTO SERVICE AND NEW FIRE HYDRANTS ARE OPERABLE.
13. SUCCESSFULLY TEST, DISINFECT, AND FLUSH WATER MAIN, AND OBTAIN ACCEPTANCE OF THE WATER MAIN BY THE CITY OF JOLIET, PRIOR TO MAKING WATER SERVICE CONNECTIONS. FLUSH PIPELINES TO OBTAIN A VELOCITY OF 2.5 FT/S PER AWWA STANDARD C651.
14. SEWER TESTING, CLEANING, AND TELEVISIONING REQUIREMENTS: ALL SANITARY SEWER MAINS SHALL BE DEFLECTION TESTED AND AIR TESTED PER THE LATEST EDITION OF THE "STANDARD SPECIFICATIONS FOR WATER AND SEWER CONSTRUCTION IN ILLINOIS". ALL NEWLY CONSTRUCTED SEWER MAINS SHALL BE CLEANED AND TELEVISED PRIOR TO BEING PUT INTO SERVICE.
15. USE RESTRAINED MECHANICAL JOINT FITTINGS WITH MEGALUG TO PLUG/CAP EXISTING WATER MAINS TO REMAIN IN SERVICE AND FOR EXISTING WATER MAINS TO BE ABANDONED. PLUGS/CAPS ON WATER MAIN TO REMAIN IN SERVICE SHALL INCLUDE AN ADEQUATELY SIZED CAST-IN-PLACE CONCRETE THRUST BLOCK AS DIRECTED BY THE CITY.

16. PAVEMENT RESTORATION WILL BE MEASURED IN PLACE AND THE AREA COMPUTED IN SQUARE YARDS. ALL AREAS DISTURBED WILL BE REPLACED, BUT THE MAXIMUM ALLOWABLE WIDTHS USED FOR PAY QUANTITY CALCULATIONS WILL BE 6 FEET CENTERED ON THE PIPE. IF THE CONTRACTOR RELOCATES THE TRENCH AWAY FROM THE CURB AND GUTTER, THE PAVEMENT PATCH WILL EXTEND FROM THE SAWCUT IN THE EXISTING PAVEMENT TO THE FACE OF THE GUTTER AND THE MAXIMUM ALLOWABLE WIDTH OF 6 FEET WILL BE USED FOR PAY QUANTITY CALCULATIONS.
17. REPLACE ALL CONCRETE SIDEWALKS DISTURBED BY CONSTRUCTION TO THE NEAREST CONSTRUCTION JOINT. A MAXIMUM LENGTH OF TEN LINEAL FEET PER CROSSING WILL BE UTILIZED FOR PAY QUANTITY CALCULATIONS.
18. AS-BUILT DRAWINGS SHALL BE PREPARED BY THE CONTRACTOR AND SUBMITTED TO THE ENGINEER AS SOON AS THE PROJECT IS COMPLETED. ANY CHANGE IN THE LENGTH, LOCATION, OR ALIGNMENT SHALL BE SHOWN IN RED.
19. EROSION CONTROL WILL BE CONSTRUCTED IN ACCORDANCE WITH STANDARD SPECIFICATIONS FOR SOIL EROSION AND SEDIMENT CONTROL AS CONTAINED IN IEPA/WPC/87-012 OR CURRENT EDITION.
20. THE CITY OF JOLIET WATER DEPARTMENT SHALL BE RESPONSIBLE FOR COMPLETING ALL TAPS TO EXISTING WATER MAINS. CONTRACTOR WILL BE RESPONSIBLE FOR CALLING 815-724-4230 TO SCHEDULE AN APPOINTMENT WITH THE CITY WATER DEPARTMENT. APPOINTMENTS ARE AVAILABLE ON TUESDAYS AND THURSDAYS.

21. IT SHALL BE THE CONTRACTOR'S DUTY AND RESPONSIBILITY TO ASCERTAIN AND EXECUTE THE MEANS, METHODS, AND SEQUENCE OF CONSTRUCTION IN ACCORDANCE WITH THE DRAWINGS, SPECIFICATIONS, AND OTHER CONTRACT DOCUMENTS. THIS SHALL INCLUDE, BUT SHALL NOT BE LIMITED TO, THE EXCLUSIVE DUTY AND RESPONSIBILITY TO PROVIDE FOR WORKPLACE SAFETY AND WORKER SUPERVISION. IT SHALL EXCLUSIVELY BE THE CONTRACTOR'S DUTY AND RESPONSIBILITY TO INVESTIGATE AND ASCERTAIN THE CURRENT PHYSICAL STATE AND OPERATIONAL STATUS OF THE CITY'S WATER SUPPLY SYSTEM AND THE CITY'S SANITARY SEWER SYSTEM, INCLUDING WHETHER A WATER MAIN OR OTHER VESSEL IS OPERATIONAL, CONTAINS WATER, IS PRESSURIZED, OR IS OTHERWISE SAFE TO ALTER. ANY INFORMATION PROVIDED BY THE CITY, OR ITS EMPLOYEES AND CONSULTANTS, REGARDING THE STATE OF ITS WATER SUPPLY AND SANITARY SEWER SYSTEMS IS PROVIDED AS A COURTESY TO THE CONTRACTOR BUT IS NOT WARRANTED TO BE TRUE AND MAY NOT BE RELIED ON BY THE CONTRACTOR IN SATISFACTION OF, OR TO DIMINISH, ITS EXCLUSIVE DUTY TO ASCERTAIN AND EXECUTE THE MEANS, METHODS, AND SEQUENCES OF CONSTRUCTION IN ACCORDANCE WITH THE DRAWINGS, SPECIFICATIONS, AND OTHER CONTRACT DOCUMENTS AND ITS EXCLUSIVE RESPONSIBILITY TO PROVIDE FOR WORKPLACE SAFETY AND WORKER SUPERVISION.

22. WATER SERVICE INSTALLATION WORK MUST BEGIN WITHIN 7 DAYS OF IEPA APPROVAL. FINAL PAVEMENT RESTORATION MUST BE COMPLETED WITHIN 21 DAYS AFTER THE LAST COMPLETED WATER SERVICE CONNECTION ON ANY ONE STREET OR MOVING THE EXCAVATION CREW AND EQUIPMENT TO ANOTHER STREET. THE CONTRACTOR HAS THE OPTION TO INSTALL TEMPORARY PAVEMENT AT NO ADDITIONAL COST TO THE CITY WITHIN 7 CALENDAR DAYS. THE CITY CAN STOPE OPERATIONS UNTIL TEMPORARY PAVEMENT IS PLACED OR PERMANENT PAVEMENT RESTORATION IS COMPLETE.

APPENDIX E

Pretreatment Questionnaire

City of Joliet – Service Area Wastewater and Pretreatment Survey



Company Name: _____
 Address: _____
 City, State, Zip: _____
 Site Representative: _____
 Title: _____
 Site Phone: _____
 Email: _____

Complete this form with the values for each item anticipated to exist when the business is in operation.

Number of units in building occupied by this company: Stand-alone building Multiple Units: # of Units: _____

Number of Employees: _____ 1st Shift _____ 2nd Shift _____ 3rd Shift

Operating Days: Mon Tues Wed Thurs Fri Sat Sun

Operating Hours Per Day (Mon-Fri): _____ (Sat-Sun): _____

Date That Service / Production Began at this site: Month _____ Year _____

What services are performed or products produced at this site?

What raw materials are used on site?

Does your business do manufacturing at this facility? Yes No

Does your business do assembly or fabrication at this facility? Yes No

Does your business have an office at this facility? Yes No

Does your business have a warehouse at this facility? Yes No

Does your business have a cafeteria that prepares meals at this facility? Yes No

Does your business discharge process wastewater (non-domestic) to the sewer? Yes No

Description of process waste discharged: _____

Does your business treat your discharge at any point within your process? Yes No

Does your business have any process waste hauled offsite? Yes No

Description of process waste hauled: _____

Does the firm store liquids in drums (typically 55 gal.)? Yes No

If yes, how many drums: Less Than 5 drums: 5 or more drums:

Drum general substance: _____

Does the firm store liquids in totes or bulk tanks? Yes No

If yes, how many totes: _____ How many bulk tanks: _____

Tote or bulk tank general substance and number of gallons: _____

Does your facility use any materials which include, but are not limited to, cleaning products, raw materials or chemicals in a process which contain PHOSPHOROUS in the ingredients? Yes No

Are any inks or dyes used: Yes No

If yes, are any inks or dyes washed down the drain: Yes No

Does your firm precondition your water? Yes No

If yes, check how: Water Softener Reverse Osmosis Ion Exchange Distilled

Does your business have laundry facilities on site? Yes No

Do you have a backflow preventer? Yes No

APPENDIX F

Critical Customer Questionnaire



Physical Building Details

Building Name: _____

Address: _____

Address Line 2 (optional): _____

ZIP/Postal Code _____

1. Emergency contact information

Company: _____

Job Title: _____

Name: _____

Phone: _____

Email: _____

2. Alternate Emergency contact information

Job Title: _____

Name: _____

Phone: _____

Email: _____

3. If there is a building engineer; please provide contact information

Job title: _____

Name: _____

Phone: _____

Email: _____

4. Please select facility that corresponds to your facility type. If you select other, please describe why the property is designated as critical, including description of potential impacts from water or sewer disruption.

Hospitals/Medical Centers (including dialysis centers)

Nursing Homes/Assisted Living/Homeless Shelters

Universities/High Schools/Middle Schools/Elementary/Preschools/Day Care Centers

Public Shelters/Cooling Centers/Pools

First Responder Organizations/Police/Fire/EMTs

Power Providers

Potable Water Haulers

State/Local Emergency Management Agencies

Local/Federal Government Facilities necessary for public safety/health

Mass Transit Stations

Radio/TV Broadcast Centers

Other (please specify)

5. Describe operational impacts if water is available for flushing toilets and cleaning but not for consumption purposes.

for less than 24 hours _____

for greater than 24 hours _____

6. Describe operational impact if water is not available due to a construction or distribution system.

failure for less than 24 hours _____

failure for greater than 24 hours _____

7. If you have a written emergency or contingency plan that establishes how long the property can operate with limited or reduced water/sewer services, how long is your contingency period?

8. If there is an individual at your organization who is responsible for emergency planning, please provide contact details:

Job title: _____

Name: _____

Phone: _____

Email: _____

9. What is the total occupancy served by your property's water system? (e.g. number of employees, number of residents, number of visitors, and number of buildings)?

10. If your property serves a vulnerable population (e.g. ill, elderly, children), please describe the population type and quantity of people.

11. If your property provides a vital public health or public safety purpose, please describe.

12. If you have potable water storage tanks onsite, please indicate the volume of onsite potable water storage.

13.If you have bottled water stored onsite, please indicate how much bottled water is stored onsite.

14.Do you have a vendor agreement or shared services agreement with another property for emergency potable/non potable water resupply?

Yes No

15.If you have a supply of portable toilets, what is the quantity?

16.If you have an emergency power source, such as a generator or quick connect for a generator, please describe.

17.What is your City of Joliet Water Account Number (located on bill)? _____

18.If your organization has more than one City of Joliet account, please provide account numbers:_____

19.Is there any other information that you want to share with City of Joliet regarding emergency water/sewer impacts on your property or facilities?_____

APPENDIX G

Project Closeout Checklist

City of Joliet - Public Utilities Project Closeout Checklist



Project Name: _____
Address: _____
Site Representative: _____
Title: _____
Site Phone: _____
Email: _____

Sanitary Sewer

1. Manhole Vacuum Testing Completed..... Yes___ No___ N/A___
2. Sewer Vacuum Testing Completed..... Yes___ No___ N/A___
3. Sewer Mandrel Testing Completed..... Yes___ No___ N/A___
4. Televising Videos Completed..... Yes___ No___ N/A___
5. IEPA Construction Permit Received..... Yes___ No___ N/A___
6. Locating Wire Continuity Testing Completed..... Yes___ No___ N/A___

Punch List

1. City of Joliet Punchlist Completed..... Yes___ No___ N/A___

Water Main

1. Pressure Testing Completed..... Yes___ No___ N/A___
2. Chlorination Testing Completed..... Yes___ No___ N/A___
3. IEPA Operating Permit Received..... Yes___ No___ N/A___
4. Locating Wire Continuity Testing Completed..... Yes___ No___ N/A___

Lift Stations

1. Operation Manual..... Yes___ No___ N/A___
2. Startup Meeting Held..... Yes___ No___ N/A___

Easements

1. PDF Copy of Recorded Plat of Easement(s)..... Yes___ No___ N/A___
2. CAD File of Plat of Easement..... Yes___ No___ N/A___

Geographic Information System (GIS) Field Data Collected During Construction

1. City Reviewed & Approved GIS Data..... Yes___ No___ N/A___

Record Drawings

1. As-Built Conditions Surveyed..... Yes___ No___ N/A___
2. PDF and CAD File submitted..... Yes___ No___ N/A___

Water Account

1. Water Account Setup..... Yes___ No___ N/A___
2. Backflow Device Registered..... Yes___ No___ N/A___

Note: The Public Works Department has a separate closeout process.

APPENDIX H

Lift Station Closeout Checklist

City of Joliet – Lift Station Closeout Checklist



Project Name: _____
 Address: _____
 Site Representative: _____
 Title: _____
 Site Phone: _____
 Email: _____

1. Pipes Between Wet & Dry Wells Have Link Seals..... Yes___ No___ N/A___
2. Construction Debris Cleaned From Wet Well & Dry Wells..Yes___ No___ N/A___
3. Guiderails Plumb.....Yes___ No___ N/A___
4. Hatch Channels Clean..... Yes___ No___ N/A___
5. Vent is Stainless Steel Material.....Yes___ No___ N/A___
6. Conduits Between Control Panel & Wet Well
 Are Galvanized Ridged.....Yes___ No___ N/A___
7. Pressure Gauges Installed..... Yes___ No___ N/A___
8. Meter Is Potted.....Yes___ No___ N/A___
9. Ground Rings/Wires Installed On Meter..... Yes___ No___ N/A___
10. Transfer Switch Tested..... Yes___ No___ N/A___
11. Startup Completed With Vendor & City staff..... Yes___ No___ N/A___
12. Means Of Locking Hatches..... Yes___ No___ N/A___
13. All Piping Painted.....Yes___ No___ N/A___
14. O&M Manual Provided To City.....Yes___ No___ N/A___
15. Draw Down Test..... Yes___ No___ N/A___
16. SCADA Test.....Yes___ No___ N/A___
17. Generator Startup Test..... Yes___ No___ N/A___
18. Landscaping Complete.....Yes___ No___ N/A___
19. Driveway Complete.....Yes___ No___ N/A___
20. Floats & Cables Secure & Floats Set Properly.....Yes___ No___ N/A___
21. Valves Operational.....Yes___ No___ N/A___

Note: this checklist is not all encompassing and additional items of work may be required before acceptance of lift station by the City of Joliet.

APPENDIX I

Water Tower Antenna Mounting Standards

WATER TOWER ANTENNA MOUNTING STANDARDS

1. Contractor(s) and subcontractor(s) shall protect existing improvements, pavements, curbs, landscaping, and structures. Any damaged items shall be repaired/replaced at the contractor's expense to the satisfaction of the owner within 30 days of project completion.
2. All unused components including but not limited to cables and hardware and construction debris shall be removed from the tower.
3. All tower and at-grade equipment shelter penetrations shall be completely sealed with the appropriate weatherproof boot.
4. All cables are required to follow the approved cable management route.
5. Cables shall be manufactured or terminated to the appropriate length and installed neatly and discreetly.
6. All new and existing components and cables shall be installed clear of climbing ladders, manway hatches, or hand-railings to not create a tripping hazard or interfere with access.
7. Include neoprene nylon washers and metal shims as necessary beneath and around all clamps, angle adapters, etc. at all painted contact points. Also use colored tape to match the tower on all painted exterior U-bolt or compression mount contact points.
8. All exterior antennas, corrals, mounting pipes, shrouds, and other components shall be painted to match the tower and shall be shop painted and inspected prior to installation. All antennas and cables may be manufactured in color match in place of paint.
9. Welded end caps are required on exterior mounting pipes.
10. Exterior cables may be field painted or radially wrapped with color matching tape as an alternative to painting. Roof top cables only require color match when mounted to top rail. All antennas/cables may be manufactured in color match in place of paint.
11. All cables shall be routed on one cable bridge from the top of the drywell tube out to the handrail. If additional cable bridges are needed due to cable length, the Unistrut used for the cable bridge shall be painted "Safety Orange".
12. Cut Unistrut ends shall be coated with a cold galvanizing compound and covered with fitted plastic covers.
13. All components and cables shall be labeled to identify the owner. Equipment & cables should be permanently marked/labeled at the equipment shelter area, at the base of the tower, at the transition from vertical to horizontal (neck/roof/balcony/roof top/etc.), and at the antenna location(s).
14. Compression style attachment methods are required. No welding, drilling, or grinding is allowed on, in, or near the tower.
15. The contractor shall field verify if their components currently extend or will extend above the FAA obstruction light after the planned upgrade. FAA lights need to extend higher above all other components. If needed an extension shall pivot near the bottom to allow for future maintenance. If needed a Detail should be included in the drawings depicting the light extension and attachment points.