

**DEPARTMENT OF  
PUBLIC WORKS**

815-724-4200 Direct  
815-723-7770 Fax  
Email: [dortiz@joliet.gov](mailto:dortiz@joliet.gov)



**150 WEST JEFFERSON STREET  
JOLIET, ILLINOIS 60432-4158**

CITY OF JOLIET

August 28, 2020

ADDENDUM NO. 1

**TO: Prospective Bidders for the 2020 Sidewalk/ Curb Replacement Project – Contract No. 2526-0920**

THE ATTENTION OF ALL PROSPECTIVE BIDDERS ON THE ABOVE REFERENCED PROJECT IS CALLED TO THE FOLLOWING LISTED MODIFICATION IN THE CONTRACT DOCUMENTS:

1. Attached is drawing for proposed curb and median replacement at Theodore St. and Caton Farm Rd. at the railroad tracks.
2. Two freight trains operate on the tracks per day at Theodore St. and Caton Farm Rd. crossings. The train timetable speed is 25 mph. No passenger trains use these tracks.
3. Service walk is to be removed and concrete step installed at 1122 Wilcox.
4. Attached is specification and detail for PCC Steps. PCC Steps item has been added to the Schedule of Prices.
5. Attached are the revised Schedule of Prices. Please remove the existing schedule of prices and insert the revised Schedule of Prices.

**The Acknowledgement of the Receipt of all Addendums must be printed clearly on the outside of your Bid Package or your Bid may not be opened.**

David D. Ortiz  
Civil Engineer I

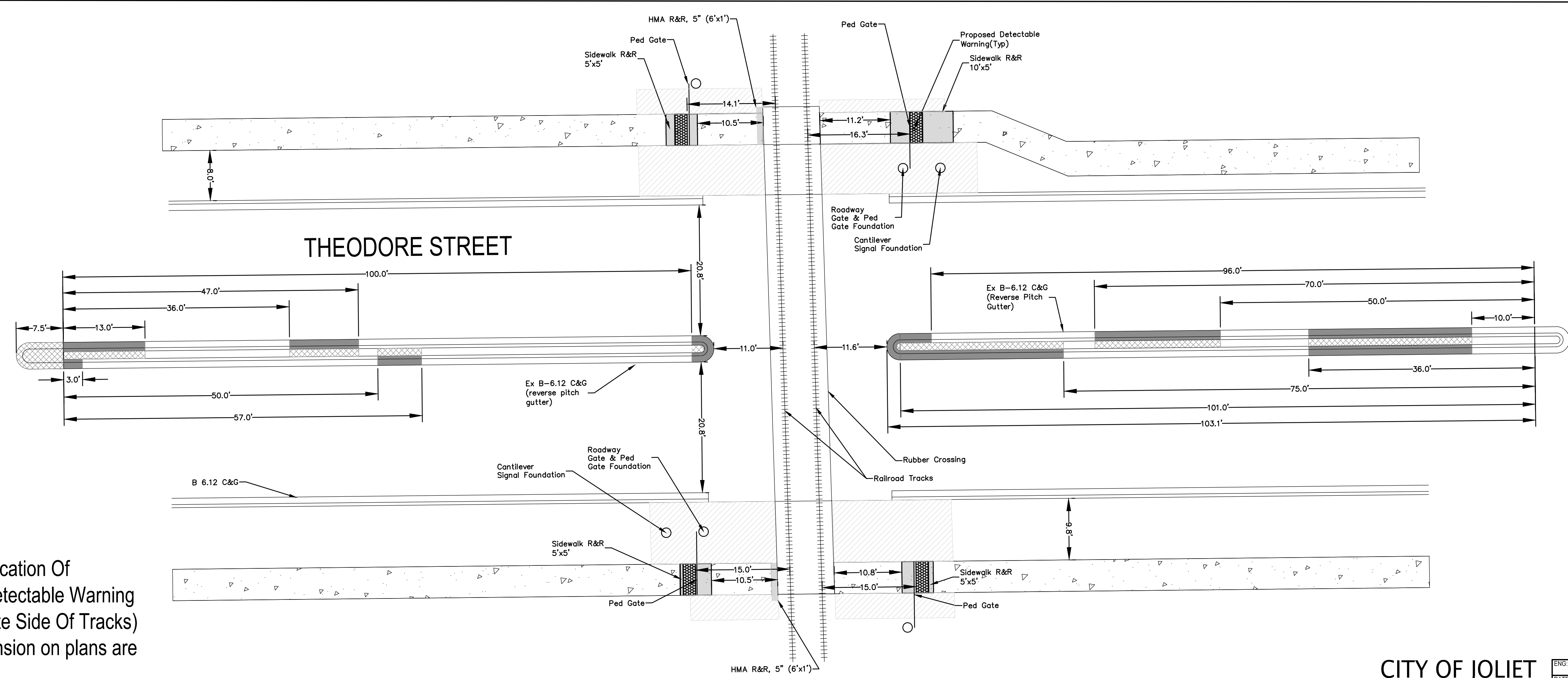
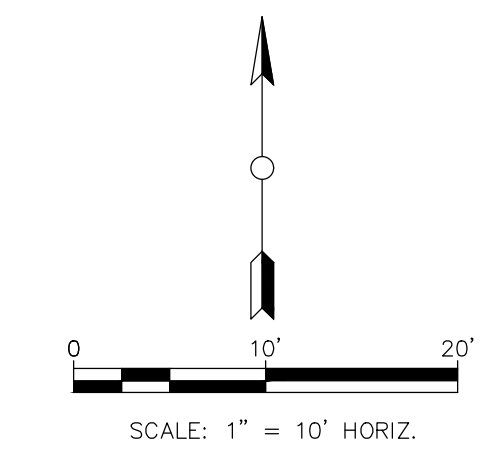
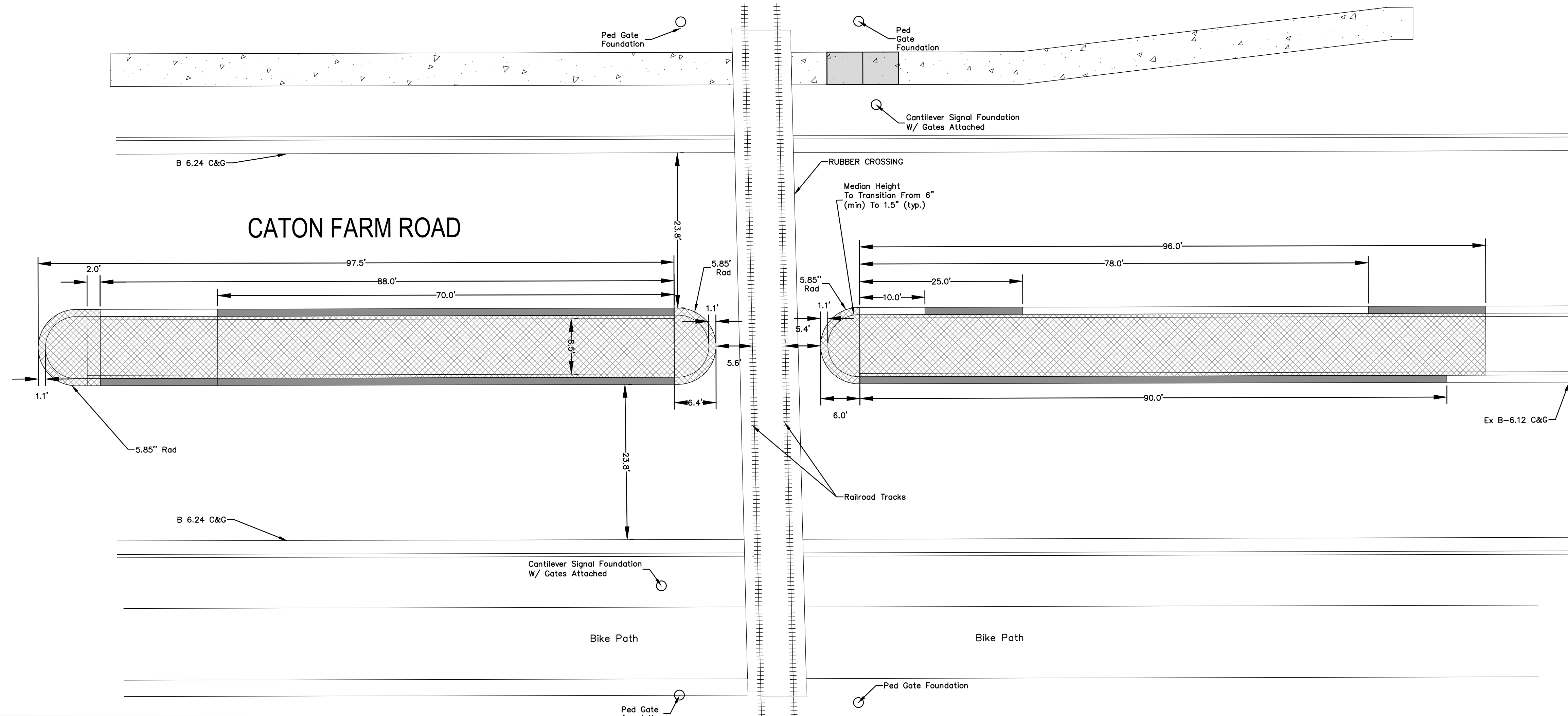

- LEGEND**
- Portland Cement Concrete Median Removal & Replacement
  - Concrete Curb & Gutter Removal & Replacement
  - PCC Sidewalk Removal & Replacement
  - Porous Granular Backfill

Contractor To Verify In Field Location Of proposed nstallation Of New Detectable Warning Is 4" In Front Of Gates (Opposite Side Of Tracks) on Theodore- variance in dimension on plans are to be approved by engineer

U:\Public Works\CAD\Projects\2020 Projects\Caton Farm - Theodore RR X-ing\Caton Farm - Theodore Rd.dwg, 8/28/2020 10:24:21 AM

XX. PCC STEPS

This work includes furnishing all material, equipment, and labor necessary to remove the existing material (including but not limited to aggregate, limestone, concrete, asphalt, and/or earth) and installing PCC steps per the "PPC Stair Type A" detail. This work shall be performed according to article 202, 311, 424 and 440 of the "Standard Specifications". The Steps shall be set on compacted 3" sub-base granular material, Ty C. The riser height shall be maximum 7". The tread run length shall be minimum 11".

Method of Measurement

This work will be measured per square foot of surface area, both horizontal and vertical, on step risers and treads, and up to two feet leading to and away from the steps.

Method of Payment

This work shall be paid for at the contract unit price, per square foot, for PCC Steps. No other compensation will be made for this work.

T= 12" (TYP)  
R= 7" (TYP)

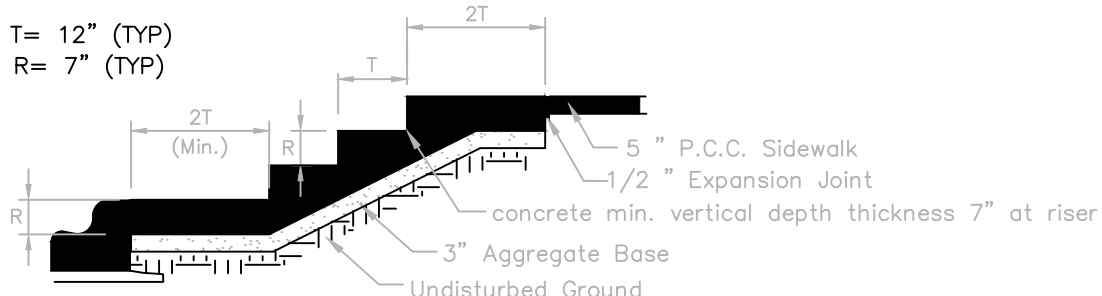

**PCC STAIR TYPE A**  
**No Scale**

**CITY OF JOLIET  
SCHEDULE OF PRICES**

ITEM N	ITEM DESCRIPTION	QUANTITY	UNITS	UNIT PRICE	COST
NO. 1	P.C.C. SIDEWALK, 5"	6800	SQ FT		
NO. 2	CONCRETE CURB & GUTTER	615	LN FT		
NO. 3	P.C.C. DRIVEWAY PAVEMENT, 6"	15	SQ YD		
NO. 4	BUFFALO BOX/ VALVE BOX ADJUSTMENT	1	EACH		
NO. 5	HOT MIX ASPHALT REMOVAL & REPLACEMENT, 3"	40	SQ YD		
NO. 6	DELINEATOR POST TO BE INSTALLED	5	EACH		
NO. 7	CURB REFLECTORS	16	EACH		
NO. 8	POROUS GRANULAR BACKFILL	111	SQ YD		
NO. 9	PROTECTIVE COAT	1050	SQ YD		
NO. 10	DETECTABLE WARNINGS	58	SQ FT		
NO. 11	CONCRETE REMOVAL ONLY/ RESTORATION WITH 5" TOPSOIL & SEED W/EROSION CONTROL BLANKET	25	SQ FT		
NO. 12	REMOVAL AND DISPOSAL OF CONTAMINATED MATERIAL	5	CU YD		
NO. 13	TREE ROOT GRINDING- 8" DIAMETER AND GREATER	12	EACH		
no. 14	TREE FRAME & GRATE TO BE REMOVED AND RE-INSTALLED	3	EACH		
no. 15	PCC STEPS	19	SQ FT		
no. 16	BRICK PAVER REMOVAL & REINSTALLATION	140	SQ FT		
no. 17	SEAL AND ADJUST MANHOLE FRAME (NON-PAVED)	1	L SUM		
no. 18	CONCRETE MEDIAN- TYPE SB-6.12	305	SQ FT		
no. 19	CONCRETE MEDIAN SURFACE- 15"	103	SQ FT		
no. 20	CONCRETE MEDIAN SURFACE- 4"	1581	SQ FT		
no. 21	RAILROAD PROTECTIVE LIABILITY INSURANCE	1	L SUM		

BIDDER'S PROPOSAL FOR IMPROVEMENTS:

CONTRACTOR NAME: \_\_\_\_\_

ADDRESS: \_\_\_\_\_

CITY/STATE/ ZIP: \_\_\_\_\_

TEL NO.: \_\_\_\_\_

EMAIL ADDRESS: \_\_\_\_\_