

**CITY OF JOLIET  
WILL COUNTY, ILLINOIS  
SPECIFICATIONS, PLANS, CONTRACT PROPOSAL,  
CONTRACT AND CONTRACT BOND**

**FOR THE**

**2020 SIDEWALK / CURB REPLACEMENT PROJECT**

**CONTRACT NO. 2526-0920**

(PRE-QUALIFICATION REQUIRED THROUGH THE ILLINOIS DEPARTMENT OF TRANSPORTATION OR  
CAPITAL DEVELOPMENT BOARD)

**APPROVED  
DEPARTMENT OF PUBLIC WORKS**

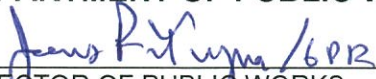
  
\_\_\_\_\_  
DIRECTOR OF PUBLIC WORKS

DATE: 08/13, 2020

**APPROVED  
DEPARTMENT OF PUBLIC WORKS**

  
\_\_\_\_\_  
PUBLIC WORKS ADMINISTRATOR

DATE: 08/13, 2020

**SUBMITTED BY**

\_\_\_\_\_  
CONTRACTORS NAME

\_\_\_\_\_  
ADDRESS

\_\_\_\_\_  
CITY AND STATE

\_\_\_\_\_  
PHONE

DATE: \_\_\_\_\_, 2020

DEPARTMENT OF MANAGEMENT & BUDGET  
PURCHASING DIVISION  
MARGARET E. MCEVILLY  
PURCHASING/CONTRACTS ADMINISTRATOR  
PHONE: 815/724-3925  
FAX: 815/724-3929  
[mmcevilly@joliet.gov](mailto:mmcevilly@joliet.gov)



Prospective Bidders:

Enclosed are bid documents which may be of interest to your company.

Please note the date as to when these bids will be opened.

THIS BID DOCUMENT MUST BE RETURNED INTACT (THE SAME ORDER AS RECEIVED). FAILURE TO DO SO MAY INVALIDATE YOUR PROPOSAL.

ALL BIDS SHALL BE SUBMITTED IN AN OPAQUE, SEALED ENVELOPE TO THE CITY CLERK, 150 WEST JEFFERSON STREET, JOLIET, ILLINOIS 60432, PRIOR TO THE TIME AND DATE SET FORTH FOR BID OPENING IN THE NOTICE TO BIDDERS. EACH BID SHALL BE ADDRESSED TO THE CITY CLERK AND SHALL BEAR ON THE FACE OF THE ENVELOPE THE NAME OF THE BIDDER, AND A STATEMENT THAT IT IS A SEALED BID, TO BE OPENED FOR THE CONTRACT CONSIDERED, AT THE DATE AND HOUR SET FORTH IN THE INVITATION TO BID.

THE BIDDER SHALL ALSO STATE ON THE ENVELOPE THAT HE/SHE IS IN RECEIPT OF ALL ADDENDUMS TO THE CONTRACT.

ANY QUESTIONS OR CLARIFICATIONS CONCERNING THESE SPECIFICATIONS SHOULD BE DIRECTED TO MARGARET E. MCEVILLY, CONTRACT ADMINISTRATOR, PHONE NO. (815) 724-3925 OR (815) 724-3929 FAX.

ANY ORAL OR WRITTEN COMMENTS RECEIVED FROM ANY OTHER PERSON OTHER THAN THE CONTRACT ADMINISTRATOR, WILL NOT BE CONSIDERED AND ALSO, MAY INVALIDATE YOUR PROPOSAL.

THANK YOU FOR BIDDING.

MAYOR  
Bob O'Dekirk

INTERIM CITY MANAGER  
James D. Hock

COUNCILPERSONS  
Don Dickinson  
Bettye Gavin  
Larry E. Hug  
Terry Morris  
Pat Mudron  
Jan Hallums Quillman  
Sherry Reardon  
Michael F. Turk

PURCHASING/CONTRACTS ADMINISTRATOR  
Margaret E. McEvelly

**CONTRACT DOCUMENTS**

**PROJECT: 2020 SIDEWALK/ CURB REPLACEMENT PROJECT**

**DEPARTMENT: PUBLIC WORKS  
CITY OF JOLIET, ILLINOIS**

**CONTRACT NO. 2526-0920**

**JAMES D. HOCK  
INTERIM CITY MANAGER**

**MARGARET McEVILLY  
PURCHASING / CONTRACTS  
ADMINISTRATOR**

LEGAL NOTICE  
CITY OF JOLIET  
ADVERTISEMENT TO BIDS

CONTRACT NO. 2526-0920  
PROJECT NAME: 2020 SIDEWALK/ CURB REPLACEMENT PROJECT

The City of Joliet, Illinois, does hereby invite sealed bids for: **6800 SF PCC SIDEWALK; 615 LF CONCRETE CURB & GUTTER; 15 SY PCC DRIVEWAY PAVEMENT REMOVAL, 6" 58 SF DETECTABLE WARNINGS; 40 SY HOT MIX ASPHALT REMOVAL & REPLACEMENT; 140 SF BRICK PAVER REMOVAL & REPLACEMENT; 1615 SF PCC MEDIAN SURFACE, 4"; 103 SF PCC MEDIAN – TYPE SURFACE, 15"**

Bids will be received at the Office of the City Clerk, City of Joliet Municipal Building, 150 West Jefferson Street, Joliet, Illinois 60432-4156 until **9:10 A.M.** local time on **Friday, September 4, 2020** at which time they will be opened.

Due to the COVID-19 pandemic, the City of Joliet has decided to take certain steps to maintain social distancing in order to try and keep everyone safe.

The bid/proposal opening for this project will be at City Hall, 150 W. Jefferson St., Joliet, IL 60432.

With this in mind, please note, there will be NO public bid opening per se. For social distancing reasons, individuals who drop their bids off cannot stay for the bid opening. There will be at least two individuals from different departments of the City that will be present at the opening and we will videotape the opening and that video will be available to view if you wish. To see a copy of the bid opening, please send a request to [purchasing@joliet.gov](mailto:purchasing@joliet.gov). Bid results will be posted as usual on the City's website for that project and emails sent out to individuals who have subscribed to the RSS feed for that project.

It is preferred that you mail your bids/proposals. They should be addressed as follows:

**CITY OF JOLIET - SEALED BID ENCLOSED  
OFFICE OF THE CITY CLERK  
150 W. JEFFERSON ST.  
JOLIET, IL 60432**

If you do choose to hand deliver your bid/proposal, they are to be hand delivered on the West side of City Hall, 150 W. Jefferson St., Joliet, IL 60432 and marked clearly on the outside of the package with the SEALED BID NUMBER AND NAME OF THE PROJECT, DATE AND TIME OF THE BID OPENING, NAME AND ADDRESS AND PHONE NUMBER OF YOUR COMPANY on the outside of the package. All other doors will be locked. Please make sure that you tell the person that you hand the package to that it is a sealed bid/proposal for them to time stamp delivery. If dropping off a bid in person, bids must be dropped off during business hours only between 8 a.m. and 4:30 p.m.

We appreciate your patience during these trying times.

Those desiring to bid may examine the bid documents and detailed specifications in the City of Joliet Purchasing Division, 150 W. Jefferson St., Joliet, IL 60432 between the hours of 8:00 A.M. and 4:30 P.M., Monday through Friday. Electronic copies can be downloaded free of charge at <http://www.joliet.gov/bids-proposals>.

All Bidding Document holders should sign up for RSS feeds at <http://joliet.gov/departments/finance/purchasing/bids-proposals/construction-public-works> and provide your first and last name and email address to automatically receive addendums. Addendums will also be posted on the City of Joliet's website at <http://www.joliet.gov/bids-proposals>. The potential vendor/contractor remains responsible for obtaining all addenda to the original specification so they should check the specific bid page before submitting a bid to make sure they have received all addendums to a specific contract.

All bidders will be required to submit Bid Security in the form of a Certified Check, Cashier's Check or a Bid Bond in the amount of **10 percent (10%) of the Base Bid**, payable to the City of Joliet.

The successful bidder will be required to post performance Security and to provide a Certificate of Insurance as set forth in the Invitation of Bid and the General Terms & Conditions.

The City of Joliet's local qualified bidder ordinance does apply to this contract.

Bidders are required to be pre-qualified through the Illinois Department of Transportation or Illinois Capital Development Board. It is the responsibility of the bidder to ensure that their pre-qualification information is provided to the City of Joliet Purchasing Division prior to the bid opening.

The City of Joliet reserves the right to reject any and all bids, parts of any and all bids, or to waive technical errors or omissions in bids.

**The Contract shall be subject to the provisions of the *Prevailing Wage Act* (820 ILCS 130/1 et seq.) to the extent required by law and the City of Joliet Procurement Code (Section 2-430 - 2-453 of the Code of Ordinances).**

---

BID DOCUMENT FEE: **\$50.00 – Electronic download is free**

Published in the Labor Record

**Thursday, August 20th, 2020**

James D. Hock  
Interim City Manager

Margaret E. McEvelly  
Purchasing / Contracts Administrator

This contract is eligible for the local bidder preference ordinance.

If you have read all of the documentation, filled out the form found online at

<http://cityofjoliet.info/departments/finance/purchasing/prequalification-on-process>, have been prequalified by the City of Joliet as a Local Bidder and wish to be qualified as a local bidder for this contract, please sign this sheet.

VENDOR NAME \_\_\_\_\_

VENDOR ADDRESS \_\_\_\_\_

CITY, STREET, ZIP \_\_\_\_\_

CONTACT PERSON \_\_\_\_\_

SIGNATURE \_\_\_\_\_

PHONE \_\_\_\_\_

EMAIL ADDRESS \_\_\_\_\_

**Complete this form ONLY if you submitted the CITY OF JOLIET LOCAL BIDDER APPLICATION FORM from the above website AND have been approved as a local bidder.**

Also, please note, there may be other pre-qualifications that apply to this contract, like Capital Development Board or City of Joliet Financial Prequalification. Please review what is due and note this does not take the place of any of those documents.

CITY OF JOLIET  
150 WEST JEFFERSON STREET  
JOLIET, ILLINOIS 60432-4158

**CONTRACT DOCUMENTS FOR: 2020 SIDEWALK/ CURB REPLACEMENT  
PROJECT**

User Department: **PUBLIC WORKS**

Date and Time of Bid Opening: **Friday, September 4, 2020 @ 9:10 A.M.**

Bid Security: **10%**

Performance Security: **100%**

Prequalification Necessary: **YES – IDOT OR THE IL. CAPITAL DEVELOPMENT  
BOARD PREQUALIFICATION REQUIRED**

Insurance: **YES – The City of Joliet and its officers and  
employees are to be named as additional insured  
on a primary and non-contributory basis.  
Additionally, please provide an endorsement from  
your insurance carrier confirming the City of Joliet  
is additional insured, including the provision of  
legal representation in the defense of claims  
asserted against the City of Joliet.**

**Robert O'Dekirk  
Mayor**

**James D. Hock  
Interim City Manager**

**Margaret E. McEvelly  
Purchasing / Contracts Administrator**

**Council Members:**

**Don Dickinson  
Bettye Gavin  
Larry E. Hug  
Terry Morris  
Pat Mudron  
Jan Hallums-Quillman  
Sherri Reardon  
Michael F. Turk**

## INSTRUCTION TO BIDDERS

### **PROJECT: 2020 SIDEWALK/ CURB REPLACEMENT PROJECT**

NOTE: BY SUBMITTING A BID, THE BIDDER WARRANTS THAT HE HAS FAMILIARIZED HIMSELF WITH ALL REQUIREMENTS OF THE CONTRACT DOCUMENTS AS WELL AS THE CITY OF JOLIET PURCHASING ORDINANCE.

#### DEFINITIONS:

The following definitions shall apply wherever they appear in the contract documents.

CITY:	CITY OF JOLIET
OWNER:	THE CITY OF JOLIET
BID:	THE OFFER OF THE BIDDER
BIDDER:	ANY INDIVIDUAL, CORPORATION OR PARTNERSHIP WHO SUBMITS A BID.

CONTRACT DOCUMENTS - Invitation to Bid Instructions, General Conditions, Special Provisions, Specifications, Drawings, Addendums, Proposal (in so far as it is not inconsistent with other contract documents) and Contract Form.

Other definitions shall be as defined in City of Joliet Ordinance 7345 or in other Contract Documents.

#### **1. BIDS - GENERAL**

Bids shall be made in accordance with the instructions. Failure to execute proposals as required may, in the discretion of the City, be cause for rejection of the bid.

#### **2. FORMS**

Bids shall be submitted on the forms provided by the City of Joliet. Each bid must be submitted bound with all other contract documents.



3. **BLANKS; CORRECTIONS**

All blank spaces on any contract document shall be filled in with typewritten figures or ink. Any erasures or corrections shall be dated and initialed by the bidder.

4. **SUBMISSION**

Bids shall be submitted in opaque sealed envelopes to the City Clerk, 150 West Jefferson Street, Joliet, Illinois 60432-4156, prior to the time and date set forth for bid opening in the Notice to Bidders. Each bid shall be addressed to the City Clerk and shall bear on the face of the envelope the name of the bidder, and a statement that it is a sealed bid to be opened for the contract at the date and hour as set forth in the invitation to bid.

5. **EXECUTION**

Proposals shall be signed by the bidder. If the bidder is a corporation, the proposal shall bear the name of the corporation, signed by an officer authorized to bind the corporation, and sealed with the corporate seal.

6. **WITHDRAWAL**

Bids may be withdrawn previous to the time of the bid opening by written request. However, no bid shall be withdrawn within the thirty (30) day period after the time set for bid opening. Bidders withdrawing their bids prior to the time and date set for bid opening may still submit another bid if done in accordance with these instructions.

7. **WORDS AND FIGURES**

Where amounts are given in both words and figures, the words will govern.

8. **UNIT PRICE**

When unit prices are called for, bids shall include all unit cost items and alternatives shown on the proposal. When an error is made in extending total prices, the unit price will govern.

9. **TAXES**

All bids shall include all applicable taxes. The State of Illinois Sales Tax and Federal Excise Taxes are not applicable to sales made in the City.

**10. NET PRICE**

Bid prices shall be net, including therein transportation and handling charges F.O.B. City of Joliet, and shall further include all charges of whatsoever sort for labor and materials contained in the work or materials designated in the specifications and proposals.

**11. BID SECURITY**

Each bidder shall provide bid security in the amount of at least **Ten percent (10%)** of its base bid. Bid security shall be in the form of a certified check, cashier's check or bid bond issued by a surety licensed to do business in the State of Illinois. Bid security shall be made payable to the order of the City of Joliet. Bid security shall be held to ensure good faith on the part of the bidder and to be applied as liquidated damages should the successful bidder fail to execute all required contract documents or attempt to withdraw the bid prior to execution of the contract.

Personal checks and Company checks are not acceptable bid security and may result in the rejection of the bid as non-conforming.

**12. BID SECURITY RETURN**

All bid security, other than submitted by the successful bidder, will be returned to the respective bidders upon the successful execution of the contract.

**13. INTERPRETATIONS**

Interpretations of the meaning of any item in the Contract Documents shall be valid only if issued in writing by the Owner or the Owner's representative designated in the Contract Documents.

**14. FAMILIARITY WITH CONTRACT DOCUMENTS AND SITE**

Bidders shall examine all contract documents including General Conditions and Specifications, inspect and acquaint himself fully with site conditions (surface and subsurface), working conditions and restraints, if applicable, prior to the submission of his bid.

**15. ALTERNATE EQUIPMENT OR MATERIALS**

- a. Bids shall be evaluated and considered on equipment and/or materials complying substantially with the contract specifications. If any bidder deviates from the contract specifications or provides a substitute for any required equipment and/or material listed in the contract specifications, that bidder shall list such deviations and/or substitutions, including technical data when applicable, in a letter attached to the bid or on a form that may be provided by the City with the bid documents.
- b. Brand names, which may be mentioned in the contract specifications, are used only as a reference to the type and quality of equipment and/or materials desired. However, any deviation from or substitution in a brand name stated in the contract specifications shall be listed as required under paragraph (a) of this section.
- c. The City reserves the right to determine whether any deviations and substitutions listed by the bidder are within the intent of the contract specifications and will reasonably meet the service requirements of the using department.
- d. A bidder's failure to list any deviations from or substitutions in the contract specifications as required under paragraph (a) of this section may result in the rejection of the bid.

**16. DESCRIPTIVE LITERATURE: EQUIPMENT OR MATERIALS**

Each bidder bidding on contracts to furnish equipment or materials shall furnish with his proposal two (2) copies of descriptive literature on the supplies or equipment being bid and manufacturer's specifications shall be in sufficient detail to permit proper evaluation of the bid.

**17. RESPONSIBILITY OF BIDDERS**

No contract will be awarded to any person, firm, or corporation that is in arrears to the City of Joliet, Illinois upon any debt or contract, or who has failed to execute in whole or in part, in a satisfactory manner, any contract with the City of Joliet, or who is a defaulter as to surety or otherwise upon any obligation to the City of Joliet, Illinois.

**18. CITY'S RIGHT TO ACCEPT OR REJECT**

The City of Joliet reserves the right to accept any bid which may be deemed to be in the best interest of the City of Joliet. The City of Joliet further reserves the right to reject any or all bids.

**19. AWARDING OF CONTRACT**

The Contract shall be awarded to the lowest responsible bidder based on criteria as set forth in the City of Joliet Purchasing Ordinance.

**20. ALTERNATE AND MULTIPLE BIDS**

Unless otherwise indicated in these bid documents, the Contractor may not submit alternate or multiple bids as part of this bid package. The submission of more than one bid within a single bid package may be cause for rejection of any or all of the bids of that contractor.

**21. AFFIDAVITS**

The Affidavits included in these Contract Documents must be executed and submitted with the bid.

**22. ADDITIONAL REQUIREMENTS:**

In addition to any other requirement, unless otherwise expressly stated in a bid solicitation or an award of contract, all bidders must comply with the following requirements in order to submit a bid or be awarded a contract and include satisfactory evidence thereof in its bid.

- (a) The bidder shall be a duly organized legal entity in good standing with the Illinois Secretary of State and in compliance with all laws prerequisite to doing business in Illinois.
- (b) The bidder shall have a valid Federal Employer Tax Identification Number or Social Security Number.
- (c) The bidder shall be an equal opportunity employer and comply with Section 2000(e) of Chapter 21, Title 42 of the United States Code and Executive Order No. 11246.
- (d) The bidder shall provide certificates of insurance indicating the following coverages if called for in the bid solicitation: general liability, workers compensation, completed operations, automobile, hazardous occupation and product liability.
- (e) The bidder shall comply with all provisions of the Illinois Prevailing Wage Act (820 ILCS 130), including wages, medical and hospitalization insurance and retirement for those trades covered in the Act.
- (f) All contractors and sub-contractors performing services covered by the Illinois Prevailing Wage Act shall submit to the City the certified payrolls required by the Act, as amended by Illinois Public Act 94-0515.
- (g) For construction projects (construction of new facilities, renovation of existing facilities or road construction projects) over \$25,000.00, the bidder must provide apprenticeship and training programs that are either registered with the United States Department of Labor's Bureau of Apprenticeship and Training or are reasonably equivalent to such programs.

## **GENERAL CONDITIONS**

**Please see the City of Joliet Special Provision and General Conditions Booklet  
Adopted February 29, 2016 available on [Cityofjoliet.info](http://Cityofjoliet.info).**

## SPECIAL PROVISIONS

The following Special Provisions supplement the most current version of the "Standard Specifications for the Road & Bridge Construction", and the "Supplemental Specifications and Recurring Special Provisions". The above named publications shall hereinafter be referred to as the State Specifications, which apply to and govern this project.

1. **WORK AREA:**

This contract includes Sidewalk/Curb Removal and Sidewalk/Curb Replacement on public property as designed by the City of Joliet. The Director of Public Works or his designee shall designate the locations and areas where work is to be performed under this contract by the Contractor. Work to be performed under this contract includes locations which are funded by the adjacent property owner on a 50/50 basis. The list of locations is provided.

This work also includes replacement of curb & gutter and concrete median at the Canadian National/ Wisconsin Central Railroad at-grade railroad crossing on Theodore St. and Caton Farm Rd.

2. **PROTECTIVE MEASURES:**

The Contractor shall include furnishing, installing, maintaining, relocating, and removing traffic control devices for regulating, warning or directing vehicle or pedestrian traffic during the construction of these improvements. All traffic protection shall conform to the State Specifications and the "Manual on Uniform Traffic Control Devices".

This work shall be considered incidental to the contract, no other compensation will be allowed.

3. **BUFFALO BOX/ VALVE BOX ADJUSTMENTS:**

If it is determined by the Engineer that any water "Buffalo Box" or valve box should be vertically adjusted to the proposed sidewalk, curb & gutter or driveway apron grade, the Contractor shall make the necessary adjustments. The contractor will provide any extensions as needed. If this vertical adjustment is made by turning the box to the correct elevation, no compensation will be considered. If excavation is necessary, this work will be paid for at the contract unit price per each "BUFFALO BOX/ VALVE BOX ADJUSTMENT".

4. **BACKFILLING AND SEEDING/SODDING:**

After the installation of the sidewalk, driveway apron and/or curb and gutter and the removal of the forms, the Contractor shall immediately backfill where the forms were placed by applying a minimum of three (3) inches approved topsoil. In areas adjacent to asphalt and aggregate driveways, the backfill shall consist of CA-6 stone up to final grade minus the depth of asphalt to be installed.

In locations with a significant grade change from the previous conditions, approved backfill shall be placed on a slope no greater than 3 to 1 *And the existing ground*

*regraded at 3 to 1 slope to match the sidewalk/ curb/ apron grade.* All locations are to be restored with three inches of topsoil and seed and as noted above. This cost, including any regrading, shall be included into the contract unit price for the respective pay item of concrete and asphalt work.

Any damage caused to the parkway outside the limits of excavation shall be restored at the contractors expense and covered with Seeding, type 1 W/ erosion control blanket.

5. **PORTLAND CEMENT CONCRETE SIDEWALK:**

This work includes furnishing all materials, equipment, and labor necessary to remove the existing material (including but not limited to aggregate, limestone, concrete, asphalt, and/or earth) and install new sidewalk in accordance with the applicable portions of Section 202, 311, 424 and 440 of the "Standard Specifications". All sidewalks shall be 5 inches thick except driveway sidewalks - which shall be six inches (6") thick and reinforced with 6" x 6" #10/#10 welded wire fabric. The additional concrete and fabric shall be considered incidental to the cost of P.C.C. sidewalk. Asphalt driveways shall be excavated only enough to provide for the sidewalk forms. The contractor is to replace asphalt and be paid for per unit price, Hot Mix Asphalt Removal and Replacement of the thickness specified. **All** sidewalks shall be placed on a three inch (3") thick mechanically compacted aggregate sub-base with gradation CA-6 or equal course gradation, which shall be considered incidental to this item. The new sidewalk shall meet the existing sidewalk or concrete driveway with a clean, straight saw-cut and 1/2 inch expansion joint material. Sidewalk shall have 1/2 inch expansion joint material along curb & gutter.

All sidewalks shall be installed with a 1/4 inch per foot slope towards the street. Sidewalk elevations shall be set so as to maintain a slope of 1/2 inch per foot between the sidewalk and the top of curb wherever possible. The maximum longitudinal slope shall be one (1) feet rise in twelve (12) feet run. If this condition is not met, the Engineer shall be contacted immediately. **All grades and form depths shall be set and checked by the Engineer prior to pouring concrete. It shall be the contractor's responsibility to verify that the Engineer has approved each location for the placement of concrete.** Ramps for the disabled shall be installed at crosswalks, as indicated by the Engineer, as per, 424001-11, 424006-04, 424011-04, 424016-05, 424021-05, or 424026-03. **A 24" wide strip of re-usable cast iron plate detectable warnings- truncated domes with contrasting color (natural patina unfinished)- shall be installed across the entire depression of the ramp (longitudinally). The cast iron plates shall be free from warps, and have vent holes or anchors.**

**Method of Measurement:**

Sidewalk will be measured for payment in place and the area computed in square feet.

Detectable warnings will be measured for payment in place and the area computed in square feet. The Detectable Warnings shall be installed across the length of the handicap accessible ramp and 24" wide from the back of curb, only. No other compensation will be allowed for this work.

**Basis of Payment:**

This work will be paid for at the contract unit price per square foot for **P.C.C. sidewalk, five inch (5")** measured in place and includes all materials, excavation, seeding, topsoil, sawcutting, wire mesh, aggregate sub-base, expansion joint material, and the removal of any existing sidewalk, and aggregate base.

Payment for the Detectable Warnings shall be paid for at the contract unit price per square foot for DETECTABLE WARNINGS as measured in place.

6. **PORTLAND CEMENT CONCRETE DRIVEWAY PAVEMENT, 6 INCH:**

This work includes furnishing all materials, equipment, and labor necessary to remove existing apron or parkway material and install P.C.C. Driveway Pavement in accordance with Article 202, 311, 423 & 440 of the "Standard Specifications".

All driveway aprons shall be six inches (6") in thickness and reinforced by 6" x 6", #10/#10 welded wire fabric. All driveway aprons shall be placed on a three inch (3") thick mechanically compacted sub-base aggregate base meeting CA-6 or equal course gradation.

All driveways shall slope uniformly from the front face of the sidewalk to the back face of the depressed curb at a maximum slope of eight foot (8') run to a one foot (1') rise. The City Engineer shall be contacted immediately if this condition cannot be met. **All grades and form depths shall be set and checked by the Engineer prior to pouring concrete. It shall be the contractor's responsibility to verify that the Engineer has approved each location for the placement of concrete.** Expansion material shall be put at both ends of the approach. All driveway aprons shall be poured independently of adjacent proposed curb or sidewalk.

**Method of Measurement:**

Portland Cement Concrete Driveway Pavement, 6" will be measured for payment in place and the area computed in square yard.

**Basis of Payment:**

This work will be paid for at the contract unit price per square yard for **PORTLAND CEMENT CONCRETE DRIVEWAY PAVEMENT, 6 INCH** measured in place.

7. **COMBINATION CONCRETE CURB AND GUTTER:**

This work includes furnishing all materials, equipment, and labor necessary to sawcut and remove the existing pavement, remove existing curbing (including gutter) and install Variable height barrier curb & gutter (6" to 8" height for concrete medians). Type B-6.12 barrier, Type B barrier, monolithic curb or Type M-6.12 mountable curb in accordance



with Article 202, 311, 440 & 606 of the "Standard Specifications". Hot Mix Asphalt Replacement required as a result of this work shall be paid separately as **Hot Mix Asphalt Removal and Replacement, 3 inch**. Variable height barrier curb & gutter shall be poured directly adjacent to existing asphalt.

Monolithic curb shall only be installed if a condition exists such that the sidewalk and curb meet at the edge of the roadway and the adjacent sidewalk/curb which is being matched was installed monolithically. The curb of six (6) inch width, shall extend to a depth of eighteen inches. The standard five (5) inch sidewalk shall begin to taper six (6) inches behind the full depth of twelve inches. A control joint shall be formed six (6) inches from the face of the curb.

Variable height barrier curb & gutter (6" to 8" height for concrete medians), Type B-6.12 barrier, monolithic curb, Type B barrier, and Type M-6.12 mountable curb shall be placed on a three (3) inch thick mechanically compacted aggregate sub-base. The sub-base shall meet CA-6 or equal course gradation. Curb shall conform to standard detail 606001-07. Depressed curbing shall be placed as directed by the Engineer.

**Method of Measurement:**

Combination Concrete Curb and Gutter will be measured for payment in place in lineal foot.

**Basis of Payment:**

This work shall be paid for at the contract unit price per lineal foot for **COMBINATION CONCRETE CURB AND GUTTER**, and shall include all materials, excavation, backfill, topsoil, seeding, sawcutting, sub-base aggregate and expansion joint material.

8. **HOT MIX ASPHALT REMOVAL AND REPLACEMENT:**

This item includes the labor, equipment and materials necessary for saw cutting of existing pavement to remain, the removal of the existing pavement, and the replacement with Hot Mix Asphalt Surface Course, Class I, Mix C, N50, of the thickness specified. This work shall be performed in accordance with Section 202, 311, 440, 442 and 406 of the "Standard Specifications".

**Method of Measurement:**

Hot Mix Asphalt Removal and Replacement will be measured for payment in place and the area computed in square yard.

**Basis of Payment:**

This work will be paid for at the contract unit price per square yard for **HOT MIX ASPHALT REMOVAL AND REPLACEMENT**, of the thickness specified, as measured in place.

9. **FRAME AND GRATE TO BE FURNISHED AND INSTALLED:**

This item shall include all materials, labor and equipment necessary to furnish and install the frame and grate of the type specified on a catch basin or inlet as indicated by the engineer. This work shall be performed in accordance with Section 202, 311, 440, 442 and 406 of the "Standard Specifications". This item also includes any vertical adjustments necessary on the structure to meet grade requirements. The contractor is responsible to remove all existing frame and grates and relocate them to the nearest City of Joliet Maintenance Facility and is incidental to this item.

**Basis of Payment:**

This work will be paid for at the contract unit price, each for **FRAME AND GRATE TO BE FURNISHED AND INSTALLED** of the type specified.

10. **NOTICE TO PROCEED:**

It should be noted that the City of Joliet will make monthly payments to the Contractor for all completed work. The Contractor shall not proceed with any work until he has been notified by the City.

11. **PERFORMANCE OF WORK:**

The Contractor will be contacted, in writing, of the work locations and issued a notice to proceed. Section 12 of the Form of the Proposal allows the contractor 30 working days to complete the work. This special provision requires the work be completed by Nov 30, 2020. Failure to complete the work in the allocated time can result in the City of Joliet completing the work in which the cost for such work will be deducted from the contract.

12. **MAINTENANCE OF COMMUNICATION:**

Due to the widespread nature of the project locations, the Engineer shall be able to contact the contractor on the project site within fifteen (15) minutes.

At the Pre-Construction Meeting, the procedure for this provision will be reviewed and approved. Typical applications include mobile telephones, pagers or radio communications.

13. **MINORITY EMPLOYMENT REQUIREMENTS:**

The Bidder's attention is called to the following Equal Employment Opportunity Construction Contract Specifications:

The Contractor's aggregate workforce on all construction work covered by this contract shall include any combination of minority or female participation equaling or exceeding

ten percent (10%) of the contractor's aggregate workforce. Compliance with this specification will be measured against the total hours performed, including all subcontracts. The contractor shall provide payroll records to establish the total work hours and those hours worked by minorities and/or female prior to receiving any retainage reduction or final payment.

Non-compliance with this specification may result in the termination of this contract and/or the ineligibility of the contractor for further contracts with the City of Joliet.

**DEFINITION:**

1. Black (all person having origins in any of the Black African racial groups not of Hispanic Origin).
2. Hispanic (all persons of Mexican, Puerto Rican, Cuban, Central or South American or other Spanish Culture or origin, regardless of race).
3. Asian and Pacific Island (all persons having origin in any of the original peoples of the Far East, Southeast Asia, the Indian Subcontinent, or the Pacific Islands).
4. American Indian or Alaskan Native (all persons having origins in any of the original peoples of North American and maintaining identifiable tribal affiliations through membership and participation of community identification).

14. **REMOVAL OF EXCAVATED MATERIAL:**

All excavated material; including concrete, asphalt, and topsoil shall be removed and hauled immediately off site. At no time is any material to be placed on the roadway or within the public right-of-way (no stockpiles). Any excavated material left on site will be hauled away by the City and the cost deducted from the amount due to the contractor. Also, leaving material onsite could be considered to be in default of the contract.

15. **TESTING FOR CONTAMINATED MATERIAL:**

This item includes all materials, equipment, and labor required to test all excavated materials for environmental contaminants as dictated by the Clean Construction or Demolition Debris (CCDD) Legislation (PA 96-1416) to be incidental to the contract. It is the Contractor's responsibility to create and maintain all testing documentation to be supplied upon request.

**Basis of Payment**

All testing required shall be incidental to the contract.

16. **REMOVAL AND DISPOSAL OF CONTAMINATED MATERIAL:**

This item shall include all materials, equipment, and labor required to remove and dispose of any excavated material which tests positive for contamination in accordance with all IEPA regulations.

**Method of Measurement:**

REMOVAL AND DISPOSAL OF CONTAMINATED MATERIAL will be measured for payment in place and the volume computed in cubic yard.

**Basis of Payment**

This work shall be paid for at the contract unit price per cubic yard for REMOVAL AND DISPOSAL OF CONTAMINATED MATERIAL.

**17. SIDEWALK REMOVAL ONLY/ RESTORATION WITH 5" TOPSOIL AND SEED W/ EROSION CONTROL BLANKET:**

This item shall include all material, equipment, and labor required to for the removal ONLY of the existing sidewalk and backfilling the area with 5" of topsoil AND seeding type 1 and placing of erosion control blanket.

**Basis of Payment**

This work shall be paid for at the contract unit price per square foot for SIDEWALK REMOVAL ONLY/ RESTORATION WITH 5" TOPSOIL AND SEED W/ EROSION CONTROL BLANKET.

**18. BRICK PAVER REMOVAL AND RE-INSTALLATION:**

This item shall include all materials, equipment, and labor, required to remove and re-install the existing brick pavers and concrete border at locations directed by the engineer. The brick shall be laid on a 1" setting sand bed over a 4" Portland Cement Concrete base, over a 4" compacted aggregate sub-base type C, with sand sprinkled over the surface and worked into the joints with mechanical plate vibrator. The setting sand bed, the 4" concrete base, and the 4" compacted aggregate sub-base; Ty-C shall be considered incidental to this work. 16" Wide Geotextile strip shall be placed over 1/2" dia weep holes in concrete at 2' O/C @ low points. 1/2" Expansion material shall be placed behind curb. All concrete shall meet IDOT specifications for PCC Sidewalk. All exposed concrete shall be finished per IDOT specifications.

Where the brick pavers are to be constructed adjacent to a concrete sidewalk, landscaped or sodded area, there shall be a 4" to 14" inch PCC border constructed to secure the brick pavers. The thickness of the PCC concrete border shall be 7.25" set on 4" compacted aggregate sub-base, Ty-C. The PCC border and 4" aggregate base shall be considered incidental to the installation of the brick pavers. The brick paver, concrete, and concrete construction joint pattern shall be constructed to the same dimensions as existing.

**Method of Measurement:**

Brick Paver Removal and Re-Installation will be measured for payment in place and the area computed in square feet.

**Basis of Payment**

This work shall be paid for at the contract unit price per square foot for BRICK PAVER REMOVAL AND RE-INSTALLATION, measured in place and shall include the installation of 4" concrete base, 4" aggregate sub-base, the 7.25" concrete border, and any tree root tree trimming. No other compensation will be allowed for this work.

**19. TREE ROOT REMOVAL**

Where tree roots with a diameter less than eight (8) inches are encountered under or directly adjacent to the asphalt, sidewalk, driveway pavement, curb and/or gutter, the roots shall be cut and removed. The cost for such work shall be considered incidental to the item of work being performed. Tree roots which are of diameter equal to or greater than eight (8) inches shall be paid for separately per the contract unit price , Tree Root Grinding- 8" Diameter and Greater. This work shall be performed by a mechanical grinder to the subgrade depth; and to 6" beyond the front and back of sidewalk, curb & gutter, and pavement.

**Method of Measurement:**

Tree Root Grinding- 8" Dia. And Greater, will measured per EACH tree location (including location where tree was removed).

**Basis of Payment:**

Tree Root Grinding- 8" Dia. And Greater, will paid for at the contract unit price per EACH for a tree location (including location where tree was removed).\

**20. TREE FRAME AND GRATE**

The contractor will remove and re-install the existing frame and grate. Any unsalvageable material will be replaced as part of this work. The City has the grates in storage. The grates are to be installed by the contractor once the concrete and frame have been installed. The contractor will be responsible for delivering the grates to the site from the City's Street Department Facility at 818 E Cass St. The tree grates will need to be trimmed so that the grate is set flush over the frame.

**Method of Measurement:**

Tree Frame and Grate to be Removed and Re-Installed will measured per EACH for each tree location.

**Basis of Payment:**

Tree Frame and Grate to be Removed and Re-Installed, will paid for at the contract unit price per EACH.

**21. CONCRETE MEDIAN- TYPE SB-6.12:**

This work includes furnishing all materials, equipment, and labor necessary to remove the existing material (including but not limited to aggregate, concrete, asphalt, and/or

earth) and install new type SB-6.12 PCC median in accordance with the applicable portions of Section 202, 311, 440 and 606 of the "Standard Specifications". The median shall be poured directly adjacent to the existing asphalt. Median shall be placed on a four inch (4") thick mechanically compacted aggregate sub-base with gradation CA-6 or equal course gradation, which shall be considered incidental to this item. The Type SB-6.12 median shall meet the proposed barrier curb height. The median shall be installed with minimum ¼" cross slope.

**Method of Measurement:**

Concrete Median Type SB-6.12 will be measured for payment in place and the area computed in square feet.

**22. CONCRETE MEDIAN SURFACE:**

This work includes furnishing all materials, equipment, and labor necessary to remove the existing material (including but not limited to aggregate, concrete, asphalt, and/or earth) and install new type PCC median surface of the thickness specified, in accordance with the applicable portions of Section 202, 311, 440 and 606 of the "Standard Specifications". Median shall be placed on a four inch (4") thick mechanically compacted aggregate sub-base with gradation CA-6 or equal course gradation, which shall be considered incidental to this item. The median shall be installed with minimum ¼" cross slope.

**Method of Measurement:**

Concrete Median Type SB-6.12 will be measured for payment in place and the area computed in square feet.

**Basis of Payment:**

Concrete Median Type SB-6.12 of the thickness specified will be paid for at the contract unit price per Square Foot.

**23. POROUS GRANULAR BACKFILL:**

This work includes furnishing all materials, equipment, and labor necessary to furnish and install compacted CA-6 backfill material to the top of front and back of public sidewalk at and near the Theodore St. railroad crossing and as directed by the engineer. The depth of the material will be maximum 6" in front and behind the public sidewalk. The material shall be placed to extend to the back of curb and as directed by the Engineer. This work will be performed in accordance with the applicable portions of Section 202, 209 of the "Standard Specifications".

**Method of Measurement:**

This work will be paid for as measured in place per square yard as Porous Granular Backfill.

**24. DELINEATOR POST TO BE INSTALLED:**

This work includes installing delineator post on the concrete median on Theodore St. near the CN railroad. This work shall be performed per the manufacture's instructions. The post to be installed, 36" Pexco Model FG w/ 2-3" yellow HIP wraps on black base and Pexco concrete anchors bolts, will be provided by the City. The contractor will be responsible for schedule and pick-up of the post at the Street Department Maintenance Yard at 818 E Cass St.

**Method of Measurement:**

This work will be paid for as measured in place per each for Delineator Post to be Installed. No other compensation will be allowed for this item.

**25. SEAL AND ADJUST MANHOLE FRAME**

**Location:** 2811 Carol Dr.

**Description:**

For all frame adjustment work including replacements, adjustments, realignments and raises, the manhole adjustment rings shall be removed, replaced and sealed per the following specification. The Contractor may not reuse existing concrete rings during frame adjustment work. Frames that are indicated for adjustment and not replacement shall be removed, cleaned and sealed in accordance with the following specification. External chimney seals shall be included in this work. When the manhole is in the pavement, the Contractor shall be required to saw cut existing pavement to a minimum of a 5 foot by 5 foot square. This square cut shall allow for proper removal and replacement of the frame and adjustment rings and for the installation of external chimney seals.

The Contractor shall remove existing frame and cover, remove all gasket material between the cone, adjustment rings and frame, and shall wire brush clean all exposed surfaces. In addition, the Contractor shall dry all surfaces with a torch or other approved method. Existing manhole frames and covers in good condition will be cleaned and reinstalled unless specified elsewhere for replacement.

The Contractor shall remove all loose materials located at the top of the corbel and fill the voids

**Materials and Installation:**

Adjustment rings. The Contractor shall replace all adjustment rings with new precast concrete rings. Precast concrete adjustment rings shall be 2", 3", 4", 6", 12" or 24" and shall be installed concentrically above the manhole cone. The Contractor shall use the minimum amount of rings possible for the adjustment. No more than two grade rings per structure shall be allowed. No shims or other leveling devices, other than leveling rings provided by the manufacturer, will be permitted. Existing manholes below grade shall be raised to grade using precast concrete adjustment rings as directed by the Engineer. During adjustment, a maximum height of 30" of adjustment will be allowed. Where manholes are to be raised or lowered more than 30", the Engineer shall be notified so the existing cone section can be

removed, and a precast barrel section or flattop can be installed. In the event that the adjustment cannot be replaced to full height on the corbel, a flattop shall be installed. When adjusted in pavement, at least one rubber composite adjustment riser with a minimum thickness of 2" shall be installed in accordance with manufacturer's recommendations and as shown on the standard details. EJ INFRA RISER or approved equal shall be used.

External chimney seal. External chimney seals are to be installed for all frame adjustment work requiring excavation including adjustments, replacements, realignments and raises unless indicated otherwise by the Engineer. This external sealing system shall prevent leakage of water into the manhole through the frame joint adjustment area.

Acceptable external chimney seals are Infi-Shield, WrapidSeal or an approved equal. The Contractor shall have both types of approved seals onsite, so that where needed, a WrapidSeal can be used in lieu of Infi-Shield seal. The Contractor shall obtain approval from the Engineer prior to switching from Infi-Shield to WrapidSeal. WrapidSeal external seals may be required on concrete block manhole structures.

Frame seals shall remain flexible throughout a 50-year design life, allowing repeated vertical movement of the frame of not less than 2 inches and/or repeated horizontal movement of not less than one half 1/2 inch.

The seal shall be a continuous seamless band made of high quality EPDM (Ethylene Propylene Diene Monomer) rubber with a minimum thickness of 65 mils. There shall be a preformed "L" shaped corner molded into the top of the seal. The top section and the side section will extend from the "L" shaped corner at a generally 90-degree angle to each other, wherein the seal is pre-formed in substantially the same shape as when attached to the manhole structure. The thickness of the "L" shaped corner extending 1" into the top section and 1" down the side section is increased and may be at least twice the thickness of the top section reinforcing the seal at this particular area. There shall be a 2" to 3" wide strip of butyl mastic attached to the underside of top section of the seal. There shall be a 2" wide strip of butyl mastic attached to the inside of the side section at the bottom of the seal. The mastic shall be non-hardening butyl rubber sealant, with a minimum thickness of 1/8", and shall seal to the cone/top of the manhole section and over the flange of the casting frame. An aerosol primer shall be used to enhance the bond strength of the seal to the structure.

The Contractor shall excavate around the frame to a depth of at least 12 inches below the top of the cone section to allow for proper installation. The Infi-Shield Uni-Band seal sealing system shall be installed according to the manufacturer's recommendations. The top section of the seal shall extend 3" attaching to the casting base/flange with the side section covering over the entire grade adjustment ring area and onto the cone section a minimum of 2". Install external manhole chimney seal as shown on the detail, with extensions where needed to cover the entire chimney area, in accordance with the manufacturer's instructions. External chimney seals installed shall not be buried until inspected by the Engineer.

Gasket Materials. EZ-STIK or an approved equal butyl mastic sealant shall be used when rejoining the manhole frame to the precast adjustments to provide a watertight structure. The sealing compound shall be produced from blends of refined hydrocarbon resins and plasticizing compounds reinforced with inert mineral filler, and shall contain no solvents, irritating fumes, or obnoxious odors. Avoid use of overly thick gasket material such as will likely produce after-settlement of manhole frame due to long-term cold flow of gasket materials. The compound shall not depend on oxidizing, evaporation, or chemical action for its adhesive or cohesive strength. It shall be supplied in extruded rope form of suitable cross section and in such sizes to seal the joint space. The Contractor shall use two (2) complete ropes at each joint.

Interior Finish Coat. After all other adjustment work has been completed, the interior surfaces of the adjustment, from the bottom of the frame to the top of the cone section, shall have a calcium aluminate high performance mortar finish applied which is then troweled and brushed



to a smooth finish. Calcium Aluminate Cement shall be StrongSeal MS-2C or approved equal.

All manhole frame sealing within driveways shall receive internal chimney seal unless a frame adjustment is deemed necessary (extreme offsets or deterioration).

Basis of Payment:

This item shall be paid at the Contract Unit Price per Each for **SEAL AND ADJUST MANHOLE FRAME** of restoration type specified (paved or non-paved) and shall include all work necessary for the complete adjustment and sealing of each manhole frame as specified in these provisions including measurement, procurement, installation, replacement, external chimney seals, adjustment rings and restoration including but not limited to PCC Sidewalk, Seeding, Driveway Pavement and Curb and Gutter removal and replacement.

**27. RAILROAD PERMITS:**

The contractor will be responsible for obtaining right-of-entry permit to perform work within the railroad right of way to replace median, curb & gutter, and sidewalk and backfill the existing parkway on Theodore St. and Caton Farm Rd. The cost of the permit and flaggers required by railroad shall be considered incidental to the contract. No other compensation will be allowed for this work.

**RAILROAD PROTECTIVE LIABILITY INSURANCE (5 and 10) (BDE)**

Effective: January 1, 2006

Description. Railroad Protective Liability and Property Damage Liability Insurance shall be carried according to Article 107.11 of the Standard Specifications, except the limits shall be a minimum of \$5,000,000 combined single limit per occurrence for bodily injury liability and property damage liability with an aggregate limit of \$10,000,000 over the life of the policy. A separate policy is required for each railroad unless otherwise noted.

---

NAMED INSURED & ADDRESS	NUMBER & SPEED OF PASSENGER TRAINS	NUMBER & SPEED OF FREIGHT TRAINS
-------------------------	------------------------------------	----------------------------------

---

DOT/AAR No.:  
RR Division:

RR Mile Post:  
RR Sub-Division:

For Freight/Passenger Information Contact:  
For Insurance Information Contact:

Phone:  
Phone:

---

DOT/AAR No.:  
RR Division:

RR Mile Post:  
RR Sub-Division:

For Freight/Passenger Information Contact:  
For Insurance Information Contact:

Phone:  
Phone:

---

Approval of Insurance. The original and one certified copy of each required policy shall be submitted to the following address for approval:

Illinois Department of Transportation  
Bureau of Design and Environment  
2300 South Dirksen Parkway, Room 326  
Springfield, Illinois 62764

The Contractor will be advised when the Department has received approval of the insurance from the railroad(s). Before any work begins on railroad right-of-way, the Contractor shall submit to the Engineer evidence that the required insurance has been approved by the railroad(s). The Contractor shall also provide the Engineer with the expiration date of each required policy.

Basis of Payment. Providing Railroad Protective Liability and Property Damage Liability Insurance will be paid for at the contract unit price per Lump Sum for RAILROAD PROTECTIVE LIABILITY INSURANCE.

80157



**Manager Public Works**

Thomas L. Brasseur  
700 Pershing Road  
Pontiac, MI 48340

T 248-452-4854

Email: thomas.brasseur@cn.ca

**Right of Entry (ROE) License Agreement Information**

Railroad Company requires everyone (contractor, consultants, etc.) working on Railroad Company property to have a Right-of-Entry (ROE) License Agreement. No work may occur on Railroad Company property nor will flagging protection be provided until ROE License Agreement has been fully executed by both parties and returned.

Follow these steps to obtain a ROE:

1. Applicant will **Email** this completed application to thomas.brasseur@cn.ca
2. Applicant will **mail** a check for the application fee \$1000.00\* to the address listed at the end of this document
3. Applicant will **Email** a COI (Certificate of Insurance) meeting the requirements outlined in the Insurance requirements section of this document
4. Once steps 1-3 are completed, the Railroad Company will begin processing the ROE application
5. If approved, the Applicant will receive an electronic copy of the ROE agreement by email
6. Applicant will have the ROE agreement executed by Applicant's VP or president of Applicant's company
7. Applicant will return a **HARD COPY** of the partially executed ROE agreement by mail to the Railroad Company address listed at the end of this document
8. The Railroad Company will return a fully executed digital copy of the ROE License Agreement by email for the Applicants records.

Please use this form and return by email to submit application request for a Right of Entry agreement.

Contact name and Email address –

Name of Applicant/contractor and email address -

Street Address –

City, State, Zip –

Telephone –

Detailed Purpose for ROE –

Start and Completion Date of ROE –

Public Agency's Project No. –

Public Agency Easement No. (if known) –

Location of project –

Subdivision and Milepost –

FRA/AAR/DOT Crossing No. and Name –  
(Nearest to jobsite)

If unable to locate this number at jobsite, please use following links to obtain:  
<http://safetydata.fra.dot.gov/officeofsafety/publicsite/crossing/xingqryloc.aspx>

In Illinois  
<http://www.icc.illinois.gov/railroad/advanced.aspx?>

Please attach an aerial snapshot and a Google Earth kmz file to help identify specific location.

## FAQ

### What time frame can I expect to begin work and have flagging protection for my work?

A **Right of Entry License Agreement usually takes 4 to 6 weeks to obtain**. Once you have a fully executed ROE agreement, you will receive a flagging request form. This flagging request form along with prepayment for flagging fees will need to be *mailed to the physical address listed on the flagging request form*. Once this flagging request form is received, it is usually about **10 days until a flagger can be scheduled**. These are normal time frames. **Time frames can vary substantially** based on many factors. Expedited time frames may be able to be requested at an additional fee.

A brief summary of time frame for each step toward obtaining flagging protection...

1. Right of Entry License Agreement usually takes **4 to 6 weeks to obtain**.
2. Send in flagging check and flagging request form...about **1 week**
3. Once this flagging request form is received, it is usually about **10 days** until a flagger can be scheduled

### What are the insurance requirements?

Railroad Company allows outside parties to come onto Railroad Company property to perform work, such as survey or inspection work, installation of pipelines and wirelines, and other work for projects necessitating the occupancy of Railroad Company. Before commencing work, and until the license of allowing such occupancy ends or is terminated, outside parties shall provide and maintain the following insurance in form and amount with companies satisfactory to and as approved by Railroad Company.

1. Minimum insurance required of outside party:
  - A. Statutory Workers Compensation and Employer's Liability Insurance.
  - B. Automobile Liability Insurance in an amount not less than \$1,000,000 combined single limit.
  - C. Commercial General Liability Insurance (Occurrence Form) in an amount not less than **\$5,000,000 per occurrence, with an aggregate limit of not less than \$10,000,000**. The policy must name Railroad Company and its Parents as additional insureds in the following form:

Illinois Central Railroad Company and its Parents  
Attn: Thomas Brasseur  
700 Pershing Road  
Pontiac, MI 48340  
248-452-4854 (office)  
Thomas.brasseur@cn.ca

**The policy must remove any provisions excluding coverage for injury, loss or damage arising out of or resulting from doing business or undertaking construction or demolition on, near, or adjacent to railroad track or facilities using endorsement CG 2417 10 01 or equivalent approved by Railroad Company.**

- D. When outside party is required by Railroad Company or Governing Authority to purchase Railroad Protective Liability Insurance to cover work on, near or adjacent to railroad track or facilities, and outside party is not being hired for this project by Railroad Company, outside party must procure Railroad Protective Liability Insurance in the following form;

This coverage shall be written on an Occurrence Form with limits of not less than \$5,000,000 per occurrence for Bodily Injury, Personal Injury and Physical Damage to Property, with an aggregate limit of not less than \$10,000,000. The policy must name:

Illinois Central Railroad Company and its Parents  
Attn: Thomas Brasseur  
700 Pershing Road  
Pontiac, MI 48340  
248-452-4854 (office)  
Thomas.brasseur@cn.ca

- E. In the event the privileges provided herein to Applicant involve any work that could result in the discharge, spillage, disposal, release or escape of any Hazardous Material or petroleum product onto the Railroad Company's property, Applicant shall purchase and maintain in effect at all times during the term of this License a Contractor's Pollution Liability policy in an amount not less than two million dollars (\$2,000,000) combined single limit (and with a deductible not to exceed \$50,000) insuring Railroad against any and all damages, costs, liabilities and expenses resulting from on- or off-site bodily injury (including death to any person), on or off-site loss, damage or destruction of property (including that belonging to the parties hereto), and on-or off-site cleanup costs (including expenses incurred in the investigation, removal, remediation, neutralization, or immobilization of contaminated soils, surface water, groundwater or any other contamination) growing out of or incidental to any discharge, spillage, disposal, release, or escape of any Hazardous Material or petroleum product arising therefrom. For purposes of this Agreement, the term "Hazardous Material" shall include, without limit, any flammable explosives, radioactive materials, hazardous materials, hazardous wastes, hazardous or toxic substances, or related materials defined in the Comprehensive Environmental Response, Compensation and Liability Act of 1980, as amended (42 U.S.C. §§ 9601, et seq.), the Hazardous Material Transportation Act, as amended (49 U.S.C. §§ 1801, et seq.), the Resource Conservation and Recovery Act, as amended (42 U.S.C. §§ 6901 et seq.), the Toxic Substances Control Act, as amended (15 U.S.C. §§ 2601, et seq.), similar laws or ordinances enacted by any state, county or municipality in which the Property is located, or in the regulations adopted and publications promulgated pursuant to any of the above, as such laws or regulations now exist or may exist in the future.

Applicant is required to advise Railroad Company by thirty (30) day advance written notice when any work to be performed under this License may require Pollution Liability Insurance pursuant to the previous paragraph.

- F. All policies described above must include description of operations, Railroad Company milepost, highway or street name, city and state of location, project number, and Railroad Company contact person on the certificate.
2. Before commencing work, outside party shall deliver to Railroad Company a certificate of insurance evidencing the foregoing coverages and, if requested by Railroad Company, true and complete copies of the policies described above. If the policy is being issued in conjunction with, or as a result of, a city, county or state contract, the policy should be initially submitted to the respective city, county or state agency that will review it first and then forward it to Railroad Company.
3. Common Policy Provisions. Each policy described in paragraph 1, parts A through E above, must include the following provisions:
- A. Each policy shall include a waiver by the insurer of any right of subrogation against any recovery by or on behalf of any insured.
- B. Each policy shall provide for not less than thirty (30) days prior written notice to Railroad Company at the address listed above of cancellation of or any material change in that policy.

4. It is understood and agreed that the foregoing insurance coverage requirements, and outside party's compliance with those requirements, is not intended to, and shall not, relieve outside party from, or serve to limit, outside party's liability and indemnity obligations under the provisions herein.
5. Railroad Company shall have the right, from time to time, to revise the amount or form of insurance coverage required as circumstances or changing economic conditions may require. Railroad Company shall give outside party written notice of any such requested change at least thirty (30) days before the date of expiration of the then-existing policy or policies, outside party agrees to, and shall, thereupon provide Railroad Company with such revised policy or policies.
6. Insurance required of SUBCONTRACTOR:
  - A. If a SUBCONTRACTOR is to be employed by outside party to perform work on Railroad Company under or by the permission for occupancy granted to outside party by Railroad Company, before commencing work, the SUBCONTRACTOR shall provide and thereafter maintain all of the insurance described in paragraph 1, parts A through E, above, in the same forms and amounts as provided for above and subject to the other terms and conditions provided for in paragraphs 2 through 4 above.
  - B. In the alternative, before the SUBCONTRACTOR commences work for outside party on Railroad Company, outside party may provide and thereafter maintain all of the insurance described in paragraph 1, parts A through E, above, in the same forms and amounts as provided for above and subject to the other terms and conditions provided for in paragraphs 2 through 5 above, provided that all such insurance names SUBCONTRACTOR as an additional insured and all such insurance provides coverage to all additional insureds, including Railroad Company, for any liability arising out of work performed by all other additional insureds, including SUBCONTRACTOR.

## Is safety training required?

Prior to any entry onto Railroad Company's property, the employees and/or subcontractors of a Contractor, Grantee, Licensee, or Permittee shall determine by the guidelines hereinafter provided and by the work to be performed the level of safety training to be required.

All employees and/or subcontractors of a Contractor, Grantee, Licensee, or Permittee not hired by Railroad Company that will work on CN property are required to have minimum [www.contractororientation.com](http://www.contractororientation.com).

- a. EXCEPTION: Railroad Company has exempted those it classifies as "Delivery Persons" from this training. This will include contractors such as UPS, FedEx, trucking companies, etc. who merely access the property to supply materials or equipment.

All employees and/or subcontractors of a Contractor, Grantee, Licensee, or Permittee hired by Railroad Company which will work on Railroad Company property are required to have minimum CN Safety and Security Awareness training, in addition to undergoing a background check. This training and background check must be obtained through the eRailSafe.com website. If not done before, the contractor must contact e-RailSafe at 855-383-7434 to be issued either a vendor number or issued instructions on obtaining a non-railroad contractor vendor number prior to accessing the noted website. Minimum information required of a Contractor, Grantee, Licensee, or Permittee and/or their subcontractor when contacting e-RailSafe is Name, Address, Telephone, Contact Person for State Projects, DOT Contract Number, and the AAR/DOT Number. This training is good for a period of two years.

- a. EXCEPTION: Railroad Company has exempted those employees of contractors providing paving services at a road crossing under construction or repair from this requirement.
- b. EXCEPTION: Railroad Company has exempted those it classifies as "Delivery Persons" from this training. This will include contractors such as UPS, FedEx, trucking companies, etc. who merely access the property to supply materials or equipment.

All employees and/or subcontractors of a Contractor, Grantee, Licensee, or Permittee hired by Railroad Company, whose duties include and who are engaged in the inspection, construction, maintenance, or repair of railroad track, bridges, roadway, signal and communication systems, roadway facilities, or roadway machinery that will work foul of or have the potential to foul a live track are considered Roadway Workers under FRA regulations and CN Policy. They must complete the On-Track Safety Training course approved by Railroad Company and provided by R.R. Safety – AMR, P.O. Box 75, Lomira, WI 53048, telephone (920) 517-1677, email [rrsafetytraining@yahoo.com](mailto:rrsafetytraining@yahoo.com). This training must be repeated at least once each calendar year.

- a. EXCEPTION: Railroad Company has exempted those employees of contractors providing paving services at a road crossing under construction or repair from this requirement.
- b. EXCEPTION: Railroad Company has exempted those it classifies as "Delivery Persons" from this training. This will include contractors such as UPS, FedEx, trucking companies, etc. who merely access the property to supply materials or equipment.
- c. All the employees and/or subcontractors of a Contractor, Grantee, Licensee, or Permittee who will operate on-track machinery or those who will provide protection for other employees and/or subcontractors of a Contractor, Grantee, Licensee, or Permittee must also be trained on CN US Operating Rules pertaining to their duties. They must take and pass the required examination. This training is good for a period of two years.
- d. "Potential to foul a live track" is considered, at a minimum, to be working within twenty-five (25) feet of the track; or as otherwise to be determined by CN Design & Construction Department.

The employees, subcontractors, and/or agents of the Licensee and/or its contractor shall qualify for, and make available for inspection to Railroad Company's employees or other authorized personnel at all times while on Railroad Company property, a photo identification issued by [www.e-railsafe.com](http://www.e-railsafe.com), along with at least one other government-issued form of identification. Licensee and/or their contractor shall bear all costs of compliance with the requirements of this Section. Railroad Company reserves the right to bar any of employees or agents of a Contractor, Grantee, Licensee, or Permittee and/or their contractor from Railroad Company's property at any time for any reason.



**What are the costs and address to mail documents and ROE application fee check?**

**Application Fee Information:**

**Cost is \$1000.00\* for application**

\*Fee may be increased for special handling, expedited handling, or multiple reviews.

Check Payable To: Illinois Central Railroad Company

Mail To: Illinois Central Railroad Company  
**Attn: Thomas L. Brasseur**  
700 Pershing Road  
Pontiac, MI 48340

**Mailing Address Information:**

Mail To: Illinois Central Railroad Company  
**Attn: Thomas L. Brasseur**  
700 Pershing Road  
Pontiac, MI 48340

**Flagging Protection Rates:**

Basic daily rate – = \$1,300.00 per day  
Monday thru Friday regular business hours  
Includes 8 standard rate hours and 2 OT hours to set flags

Overtime rate – = \$150.00 per hour  
hours in excess of 8 hours or outside of regular business hours

Weekend or holiday rate - = \$1,500.00 per day  
\$150.00 per hour with a 10 hour minimum

**Email the completed first page above to: [Thomas.brasseur@cn.ca](mailto:Thomas.brasseur@cn.ca)**

	Subject Location	Measurement Sidewalk (SF)	Measurement Apron (SY)	Measurement Curb & gutter(LF)	Measurement Asphalt (SY)	Measurement ADA (SF)	Measurement Misc Restoration	tree root grind (lifted 3"+	Inspection Notes (by Inspector)
no. 1	DIRKSEN JR HIGH ALONG SCHOOL- 250 MIDLAND AVE	1741					25		remove service walk where where no crosswalk across Midland and no ramp on east side
no. 2	PARK RIDGE PARK (next to 2206 Park Ridge Drive)	50							
no. 3	2233 Honeywood Ct	84						1	21x4 due to parkway tree, aprno heaved and cracke also, asphalt apron
no. 4	6705 JACK ROGERS LN	172						1	sw 28x4; 15x4 all tree
no. 5	5114 WILDFLOWER CT	140						1	15x4 total, 10x4 tree- ROB HAS REMEASURED UNCERTAIN OF HIS MEAS.
no. 6	3612 Indian Head Lane	34							tree 8.5*4(0.75" shift)(10/17/18)
no. 7	3611 Indian Head Lane	32							tree 8*4(1" shift)(10/17/18)
no. 8	3621 Indian Head Lane	102			6.11				tree 10*4, del/settled 15.5*4, asph drv patch 10*5.5(wedge in place)(10/17/18)
no. 9	464 S OTTAWA STREET	205							41X5 TREE
no. 10	1024 Waverly Pl	200							50X5 (30X5 TREE)
no. 11	17 S PRAIRIE	160	3.90					1	27X5 SW, 5X7 DW APRON, ALL TREE (ROOT GRIND)
no. 12	1307 BOSTON AVE	365							58*5 DETERIORATED
no. 13	2316 WESTNEDGE LN	115							23x5 all tree; neighbor has petition on file 6/18/19, 72x4 total , possible60'x4' trees
no. 14	2314 WESTNEDGE LN	288							23x5 all tree; neighbor has petition on file 6/18/19, 72x4 total , possible60'x4' trees
no. 15	518-520 WALSH AVE	232							
no. 16	109 REEDWOOD DR	25							5X5 PO
no. 17	107 REEDWOOD DR	125							25X5 TREE (HAS ASPHALT)
no. 18	246 Rebecca- ada ramp	150		39		10			
no. 19	3029 Jeffery Dr	117.5		12.5		10	55		remove sidewalk at corner since no crosswalk going across Rebecca
no. 20	3026 Jeffrey Dr - ada ramp	96		18	2.00	20			
no. 21	3026 Jeffrey Dr	640						5	(95x5 along jeffery, 15.5 tree, 79.5 ho) 10x5, 10x5, 10x5 all tree along rebecca
no. 22	4208 BUNRATTY LN	40							16*5, 1",2" shifts(tree)(10/9/18)
no. 23	615 Reserve Lane	100							10*4(3" shift)(8/6/18)
no. 24	3911 Sierra Rose Circle	166							8*4(2" shift)(8/6/18)
no. 25	603 Sierra Rose Circle	36							9*4(2" shift)(8/6/18)
no. 26	516 Sierra Rose Circle	40							10*4 (2.5" shift)(8/6/18)
no. 27	411 Reserve Court	92							5*4(1.5" shift) 18*4(4" shift)(8/6/18)
no. 28	602 Reserve Lane	20							10*4(1.5" shift)(8/6/18)
no. 29	500 Reserve Court	20							10*4(1.5" shift)(8/6/18)
no. 30	504 Reserve Court	40							10*4(1.5" shift)(8/6/18)
no. 31	8216 Woodview Avenue	16							4*4(1" shift)(8/7/18)
no. 32	2206 Woodview Avenue	16							4*4(broken edges)(8/7/18)
no. 33	8211 Tremont Lane	52							13*4(grinded edges)(8/7/18)
no. 34	2126 Tremont Lane	32							4*4, 4*4(1.25" shift)(8/7/18)
no. 35	2124 Tremont Lane	16							4*4(cracked)(8/7/18)
no. 36	8226 Tremont Lane	20							5*4(0.75" shift)(8/7/18)
no. 37	8110 Tremont Lane	16							4*4(grinded and sunk)(8/7/18)
no. 38	2111 Tremont Lane	16							4*4(1" shift)(8/7/18)
no. 39	8223 Woodview Avenue	60							9*4(already milled down)12*4(grinded, 1" shift)(8/7/18)
no. 40	8221 Woodview Avenue	44							114*(4" dip, cracked)(8/7/18)
no. 41	1007 PEARSON	285							TREE AND SW DRIVEWAY MEAS 100% CITY, PO 50 SF
no. 42	ada ramp SE corner Bronk Rd	126		8		10			
no. 43	ada sw side cahokia & Flintrock	107		8.5	1.89	8			
no. 44	225 E CLINTON ST (CHURCH)	241					140	3	140 sf brick paver R&R
no. 45	1122 Wilcox	65.5							
no. 46	2902 Avalon Dr.			49	22.00				
no. 47	Westmore Grove & Forestgrove			21	2.67				
no. 48	2059 Winding Lakes Dr.			15					
no. 49	Carrington Lane & Quinn Drive			8					
no. 50	806 Pine Needle			3					
	sub total:	6,740.00	3.90	182.00	34.67	58.00	220.00	12.00	

	Subject Location	sidewalk, SF (parkway)	curb && gutter description	curb & gutter, lf	concrete median surface, 4" , SF	concrete median surface, 15", SF	concrete median Ty SB-6.12, SF (noses)	porous granular backfill- north description	porous granular backfill south description
No. 51	Theodore St. Railroad crossing- west		13',3',11',7'	34		31	55.00	20'x4'; 20'x8'	14'x4'; 19'x10'
No. 52	Theodore St. Railroad crossing- east		5',26',20',26',26'	103		72	10.00	20'x2'; 25'x8'	19'x4'; 19'x10'
No. 53	Caton Farm Rd. Railroad crossing-west		90',70',2'	162	765.00		168.00		
No. 54	Caton Farm Rd. Railroad crossing-east	55	90',18.5',15'	123.5	850.00		72.00		
	sub total:	55		422.5	850	103	72		
	totals:	6,795.00		604.50	1615.00	103.00	305.00		

# 2020 Sidewalk Locations

- Untitled layer
- 1. 203 S Midland Ave(Dirksen JR HS)
  - 2. 2206 Park Ridge Dr(Caton Ridge North Park)
  - 3. 2233 Honeywood Ct
  - 4. 6705 Jack Rogers Ln
  - 5. 5114 Wildflower Ct
  - 6. 3612 Indian Head Ln
  - 7. 3611 Indian Head Ln
  - 8. 3621 Indian Head Ln
  - 9. 464 S Ottawa St
  - 10. 1024 Waverly Pl
  - 11. 17 S Prairie Ave
  - 12. 1307 Boston Ave
  - 13. 2316 Westnedge Ln
  - 14. 2314 Westnedge Ln
  - 15. 518 Walsh Ave
  - 16. 109 S Reedwood Dr
  - 17. 107 S Reedwood Dr
  - 18. 246 Rebecca Rd
  - 19. 3029 Jeffrey Dr
  - 20/21. 3026 Jeffrey Dr
  - 22. 4208 Bunratty Ln
  - 23. 615 Reserve Ln
  - 24. 3911 Sierra Rose Cir
  - 25. 603 Sierra Rose Cir
  - 26. 516 Sierra Rose Cir
  - 27. 411 Reserve Ct
  - 28. 602 Reserve Ln
  - 29. 500 Reserve Ct
  - 30. 504 Reserve Ct
  - 31. 8216 Woodview Ave
  - 32. 2206 Woodview Ave

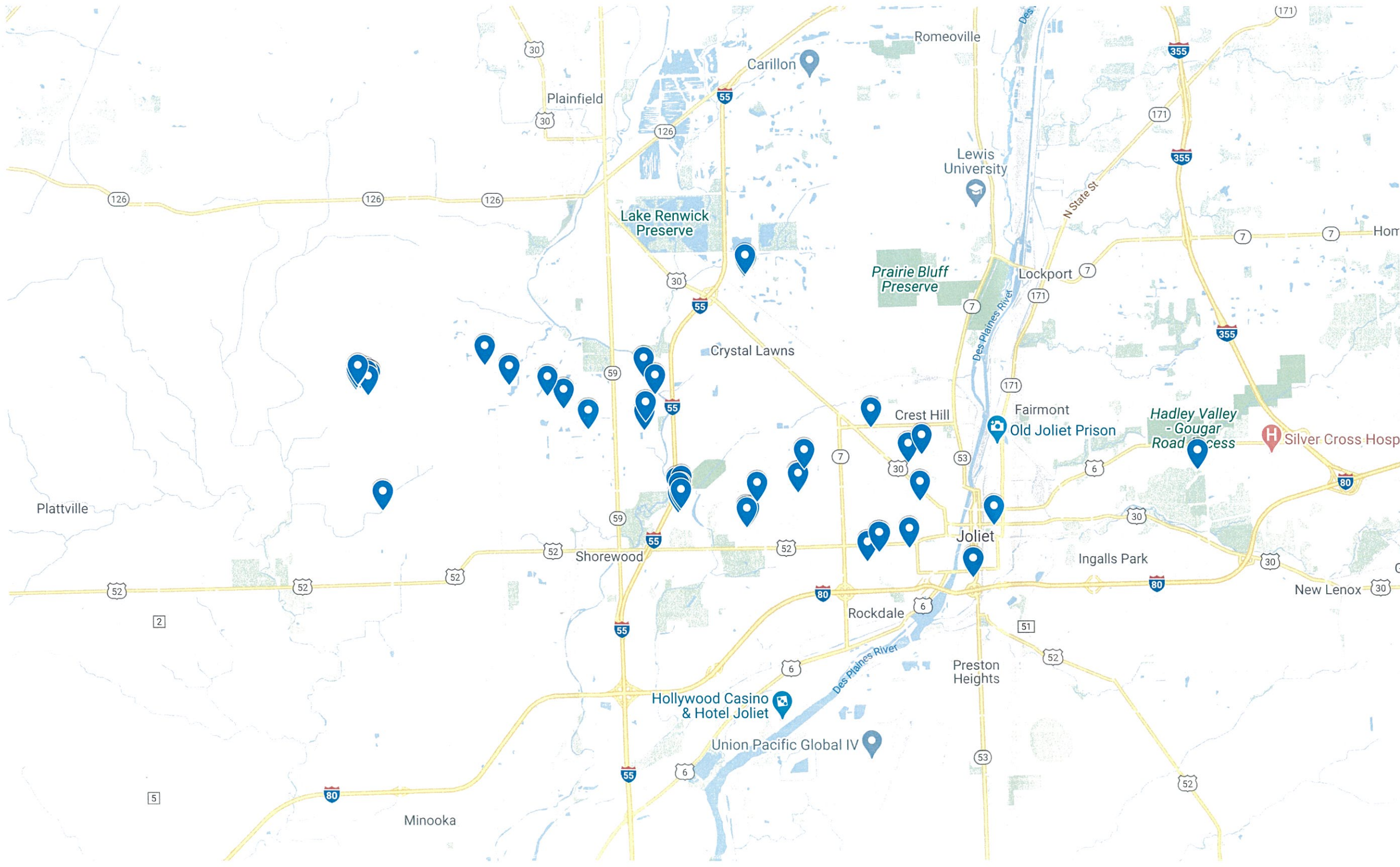

- 33. 8211 Tremont Ln
- 34. 2126 Tremont Ln
- 35. 2124 Tremont Ln
- 36. 8226 Tremont Ln
- 37. 8110 Tremont Ln
- 38. 2111 Tremont Ln
- 39. 8223 Tremont Ln
- 40. 8221 Woodview Ave
- 41. 1007 Pearson Dr
- 42. Bronk - Theodore ADA
- 43. Cahokia - Flintock
- 44. 225 E Clinton St
- 45. 1122 Wilcox St
- 46. 2902 Avalon Ave
- 47. Westmore Grove -  
Forestgrove
- 48. 2059 Winding Lakes Dr
- 49. Carrington Ln - Quinn Dr
- 50. 806 Pine Needle Ln



location No. 53 & 54- Caton Farm Rd. @ RR Tracks

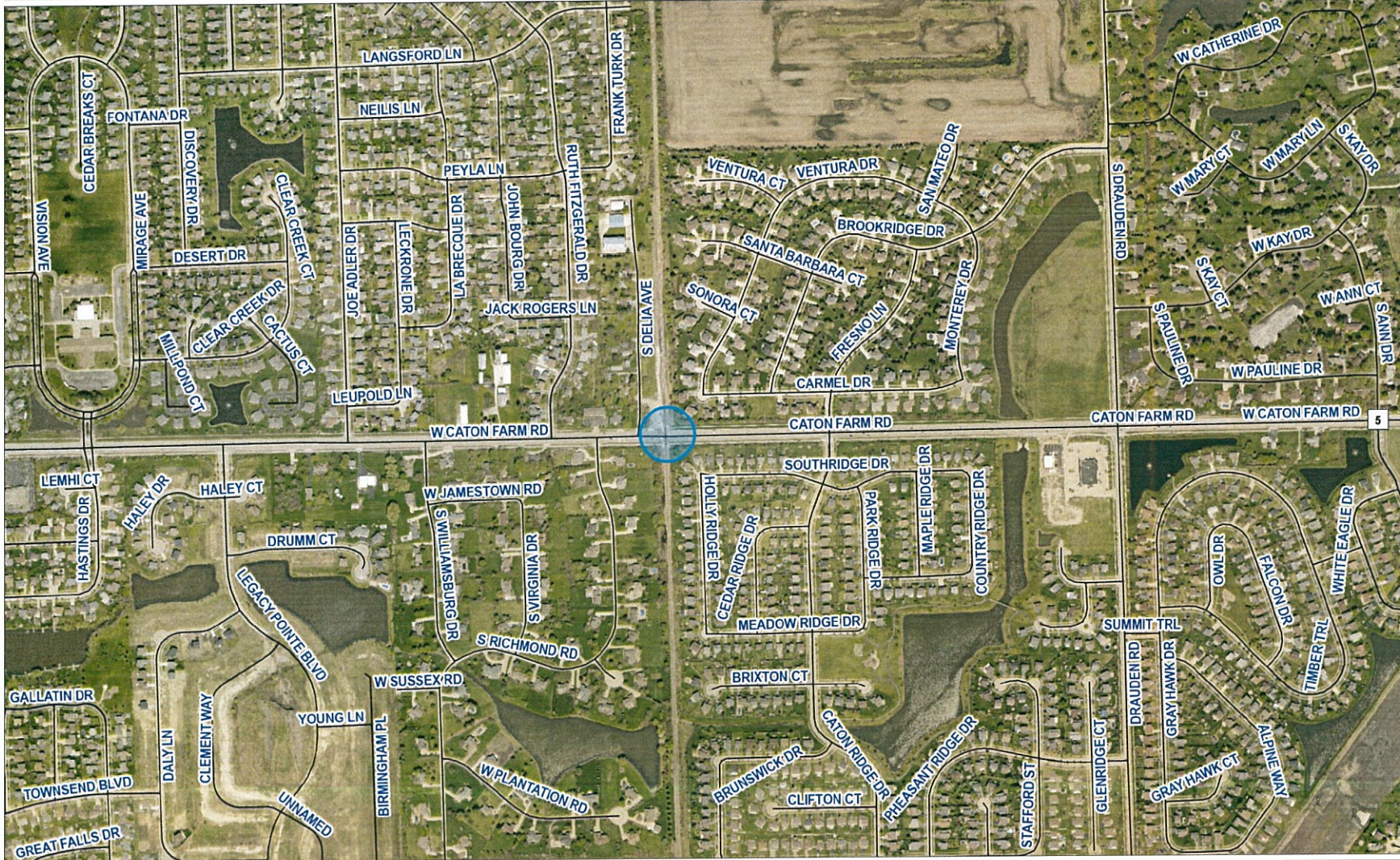

- Legend**
- Roadways
    - Federal
    - State
    - County
    - Local and Private
  - Surrounding Counties
  - Townships



Disclaimer of Warranties and Accuracy of Data: Although the data developed by Will County for its maps, websites, and Geographic Information System has been produced and processed from sources believed to be reliable, no warranty, expressed or implied, is made regarding accuracy, adequacy, completeness, legality, reliability or usefulness of any information. This disclaimer applies to both isolated and aggregate uses of the information. The County and elected officials provide this information on an "as is" basis. All warranties of any kind, express or implied, including but not limited to the implied warranties of merchantability, fitness for a particular purpose, freedom from contamination by computer viruses or hackers and non-infringement of proprietary rights are disclaimed. Changes may be periodically made to the information herein; these changes may or may not be incorporated in any new version of the publication. If you have obtained information from any of the County web pages from a source other than the County pages, be aware that electronic data can be altered subsequent to original distribution. Data can also quickly become out of date. It is recommended that careful attention be paid to the contents of any data, and that the originator of the data or information be contacted with any questions regarding appropriate use. Please direct any questions or issues via email to [gis@willcountyilinois.com](mailto:gis@willcountyilinois.com).

**Notes**



LOCATION NO. 53 & 54- THEODORE ST @ RR CROSSING

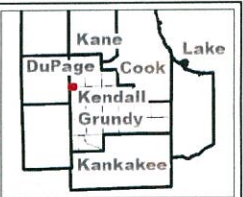
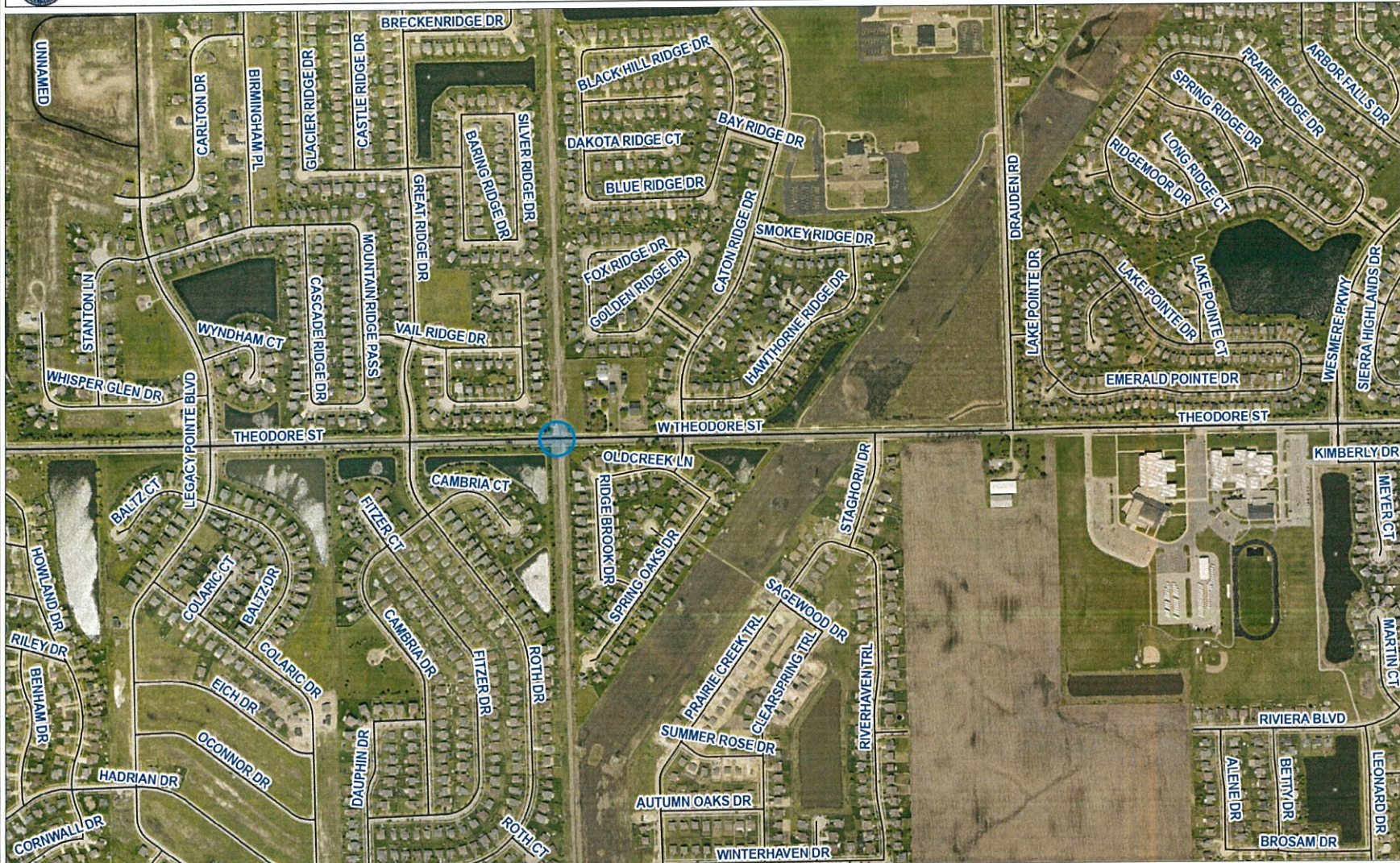

**Legend**

- Roadways
  - Federal
  - State
  - County
  - Local and Private
- Surrounding Counties
- Townships

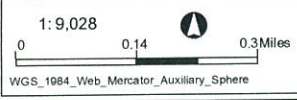

Disclaimer of Warranties and Accuracy of Data: Although the data developed by Will County for its maps, websites, and Geographic Information System has been produced and processed from sources believed to be reliable, no warranty, expressed or implied, is made regarding accuracy, adequacy, completeness, legality, reliability or usefulness of any information. This disclaimer applies to both isolated and aggregate uses of the information. The County and elected officials provide this information on an "as is" basis. All warranties of any kind, express or implied, including but not limited to the implied warranties of merchantability, fitness for a particular purpose, freedom from contamination by computer viruses or hackers and non-infringement of proprietary rights are disclaimed. Changes may be periodically made to the information herein; these changes may or may not be incorporated in any new version of the publication. If you have obtained information from any of the County web pages from a source other than the County pages, be aware that electronic data can be altered subsequent to original distribution. Data can also quickly become out of date. It is recommended that careful attention be paid to the contents of any data, and that the originator of the data or information be contacted with any questions regarding appropriate use. Please direct any questions or issues via email to [gis@wilcountylinois.com](mailto:gis@wilcountylinois.com).

**Notes**

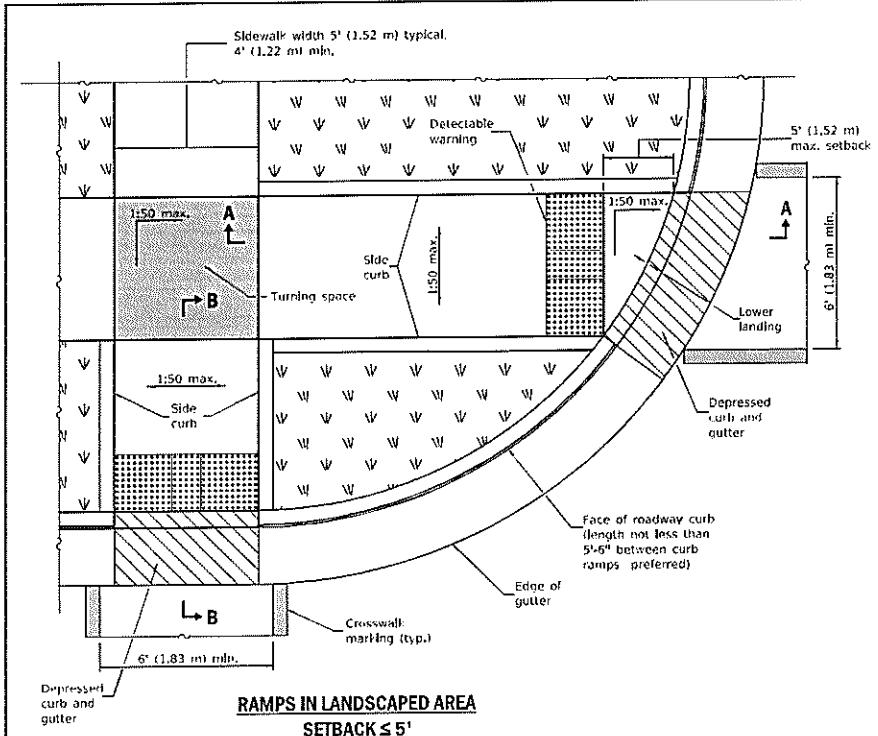

**RAMPS IN LANDSCAPED AREA**  
**SETBACK ≤ 5'**

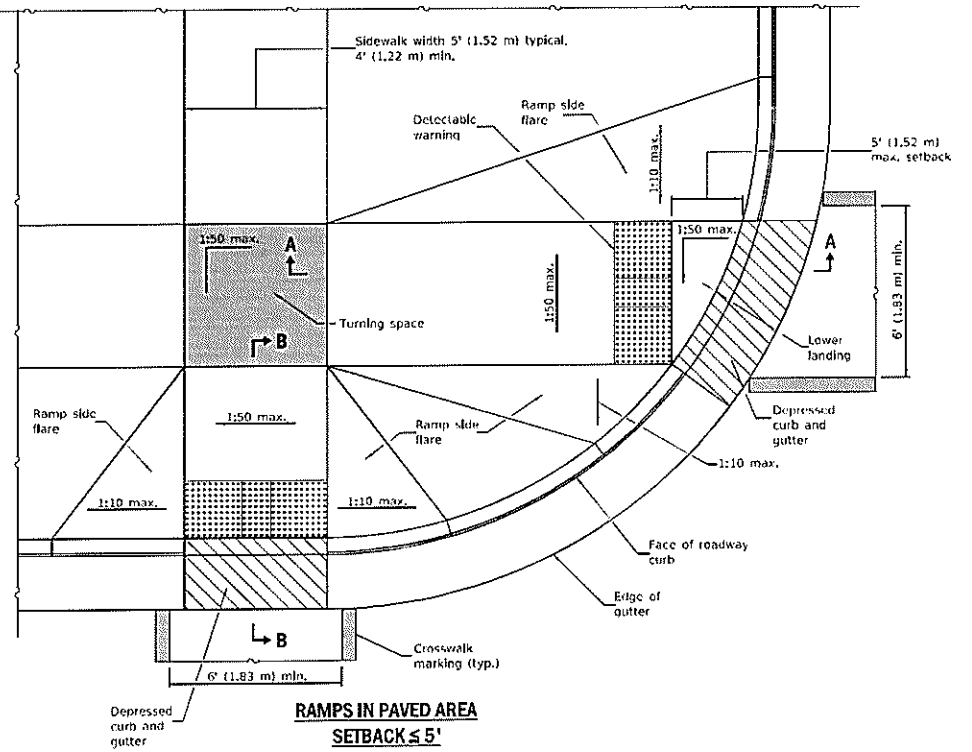

**RAMPS IN PAVED AREA**  
**SETBACK ≤ 5'**

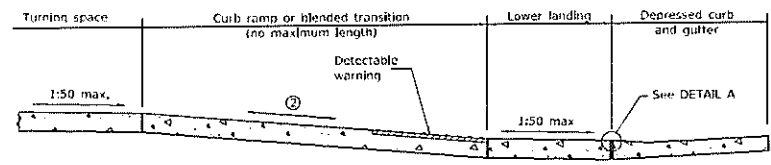

**SECTION A-A**

② The running slope of a curb ramp shall be 1:20 min. and 1:12 max. The running slope of a blended transition shall be 1:20 max.

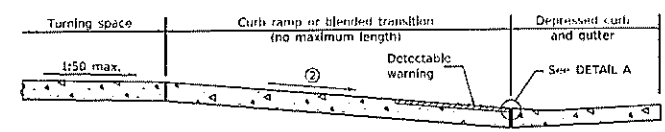

**SECTION B-B**

② The running slope of a curb ramp shall be 1:20 min. and 1:12 max. The running slope of a blended transition shall be 1:20 max.

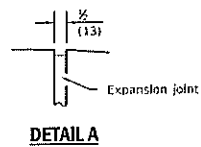

**DETAIL A**

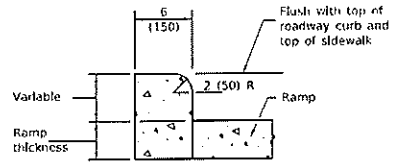

**SIDE CURB DETAIL**

Illinois Department of Transportation  
 PASCF# 12/2013 1 2019  
 ENGINEER OF POLICY AND PROCEDURES  
 APPROVED: [Signature]  
 ENGINEER OF DESIGN AND EXHIBIT

DATE	REVISIONS
1-1-19	Removed "15-foot rule" added "Blended transitions" and placement tolerances for detectable warnings.
1-1-18	Omitted diagonal slope at turning spaces and lower landings.

See Sheet 2 for GENERAL NOTES.

**PERPENDICULAR CURB RAMPS FOR SIDEWALKS**  
(Sheet 1 of 2)

**STANDARD 424001-11**



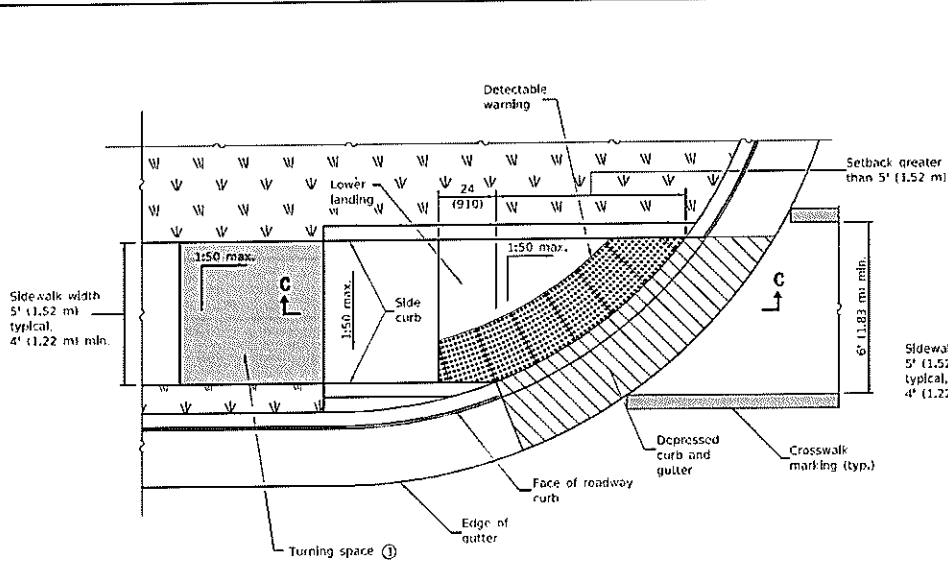

**RAMP IN LANDSCAPED AREA**  
**SETBACK > 5'**

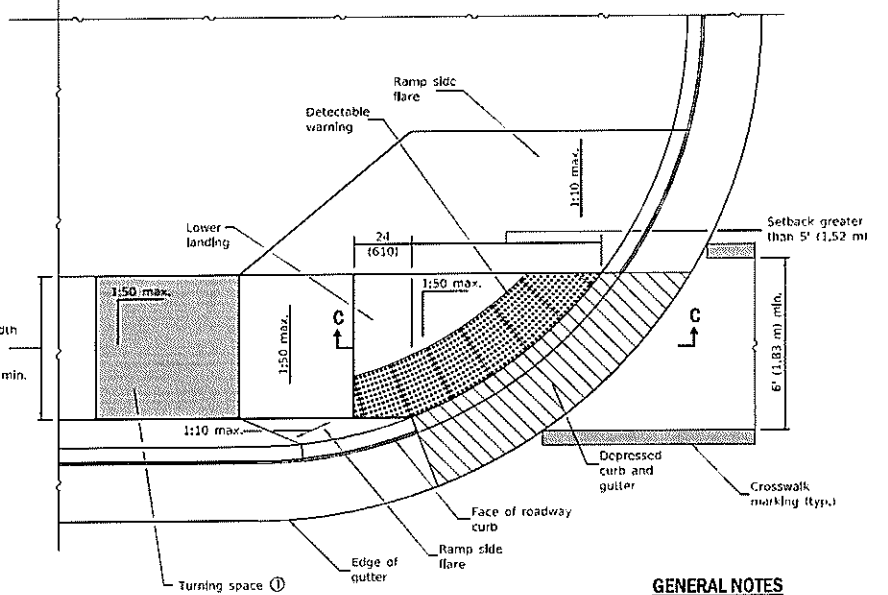

**RAMP IN PAVED AREA**  
**SETBACK > 5'**

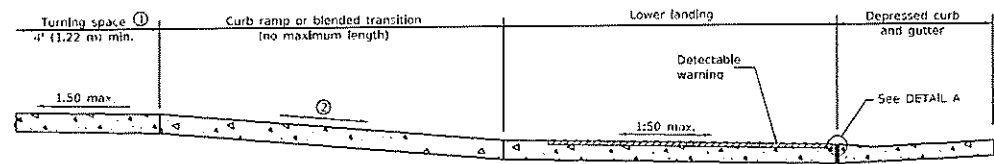

**SECTION C-C**

- ① This turning space not required for blended transitions.
- ② The running slope of a curb ramp shall be 1:20 min, and 1:12 max. The running slope of a blended transition shall be 1:20 max.

**GENERAL NOTES**

All slope ratios are expressed as units of vertical displacement to units of horizontal displacement (V:H).

Where the turning space is constrained on a side opposite a ramp, the minimum length of the turning space in the direction of the ramp-run shall be 5' (1.52 m).

Where 1:50 maximum slope is shown, 1:64 is preferred.

Detectable warnings are shown in their ideal locations but the following placement tolerances are allowed.

**Side Border** - Detectable warnings should extend the full width of the walking surface (excluding flared sides) but a border along each side up to 2 in. (50 mm) in width is allowed.

**Curb Set-Back** - Detectable warnings located at the back of curb should closely align with the curb but a gap up to 6 in. (150 mm) behind the curb is allowed.

See Standard 606001 for details of depressed curb adjacent to curb ramp.

All dimensions are in inches (millimeters) unless otherwise shown.

**PERPENDICULAR CURB RAMPS**  
**FOR SIDEWALKS**  
(Sheet 2 of 2)

**STANDARD 424001-11**

Illinois Department of Transportation

DATE: JANUARY 3, 2019

ENGINEER OF POLICY AND PROCEDURES

APPROVED: [Signature]

ENGINEER OF DESIGN AND ENVIRONMENT

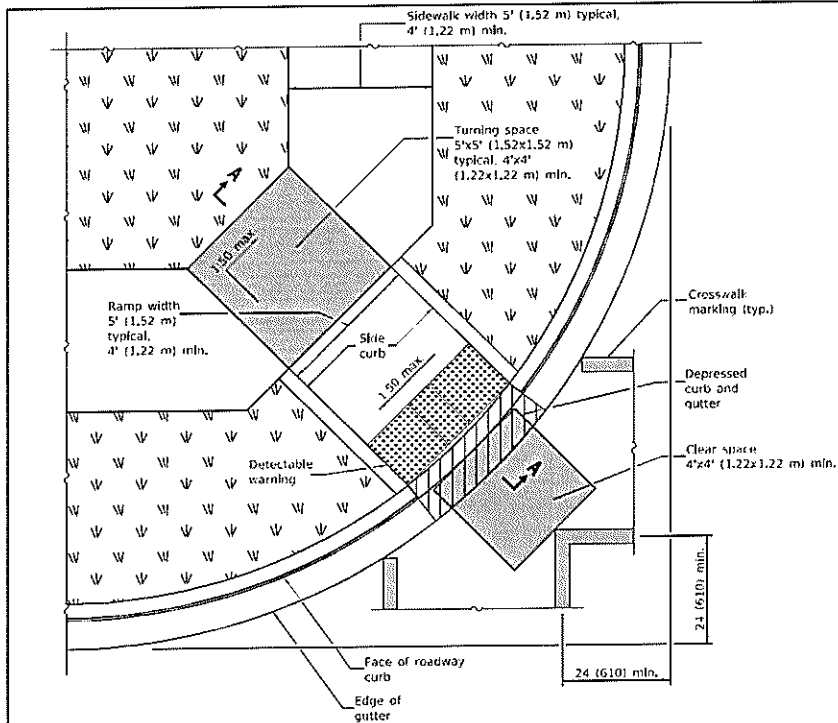

**RAMP IN LANDSCAPED AREA**

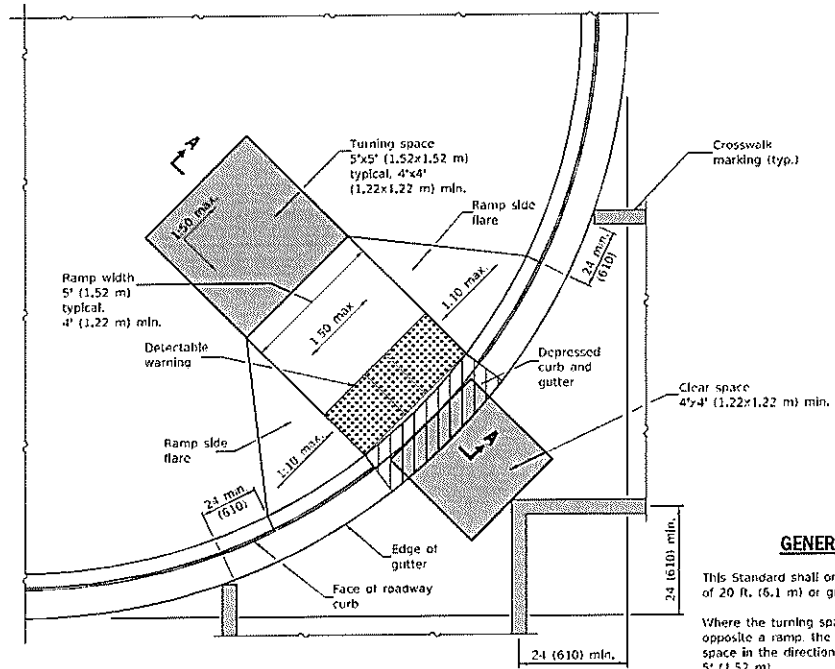

**RAMP IN PAVED AREA**

**GENERAL NOTES**

This Standard shall only be used for curb radii of 20 ft. (6.1 m) or greater.

Where the turning space is constrained on a side opposite a ramp, the minimum length of the turning space in the direction of the ramp-run shall be 5' (1.52 m).

Where 1:50 maximum slope is shown, 1:64 is preferred.

Detectable warnings are shown in their ideal locations but the following placement tolerances are allowed.

**Side Border** - Detectable warnings should extend the full width of the walking surface (excluding flared sides) but a border along each side up to 2 in. (50 mm) in width is allowed.

**Curb Set-Back** - Detectable warnings located at the back of curb should closely align with the curb but a gap up to 6 in. (150 mm) behind the curb is allowed.

All slope ratios are expressed as units of vertical displacement to units of horizontal displacement (V:H).

See Standard 606(01) for details of depressed curb adjacent to curb ramp.

All dimensions are in inches (millimeters) unless otherwise shown.

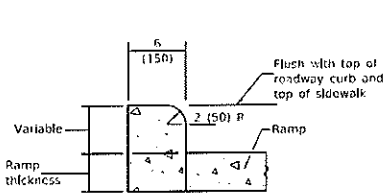

**SIDE CURB DETAIL**

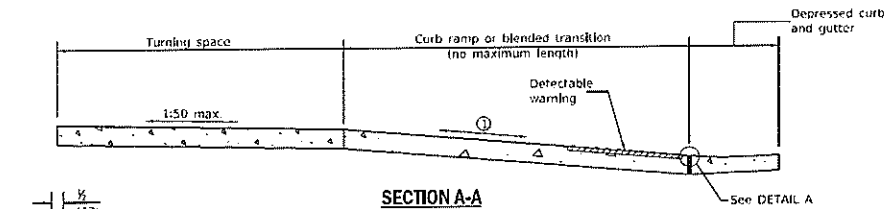

**SECTION A-A**

① The running slope of a curb ramp shall be 1:20 min. and 1:12 max. The running slope of a blended transition shall be 1:20 max.

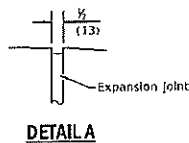

**DETAIL A**

Illinois Department of Transportation

PROJECT: *MTB* January 2, 2019

ENGINEER OF POLICY AND PROCEDURES

APPROVED: *Schultz* January 1, 2019

ENGINEER OF DESIGN AND ENVIRONMENT

21-1-1 C 0051

DATE	REVISIONS
1-1-19	Removed "15-foot rule", added "blended transitions" and placement tolerances for detectable warnings.
1-1-16	Omitted diagonal slope at turning spaces.

**DIAGONAL CURB RAMPS FOR SIDEWALKS**

**STANDARD 424006-04**

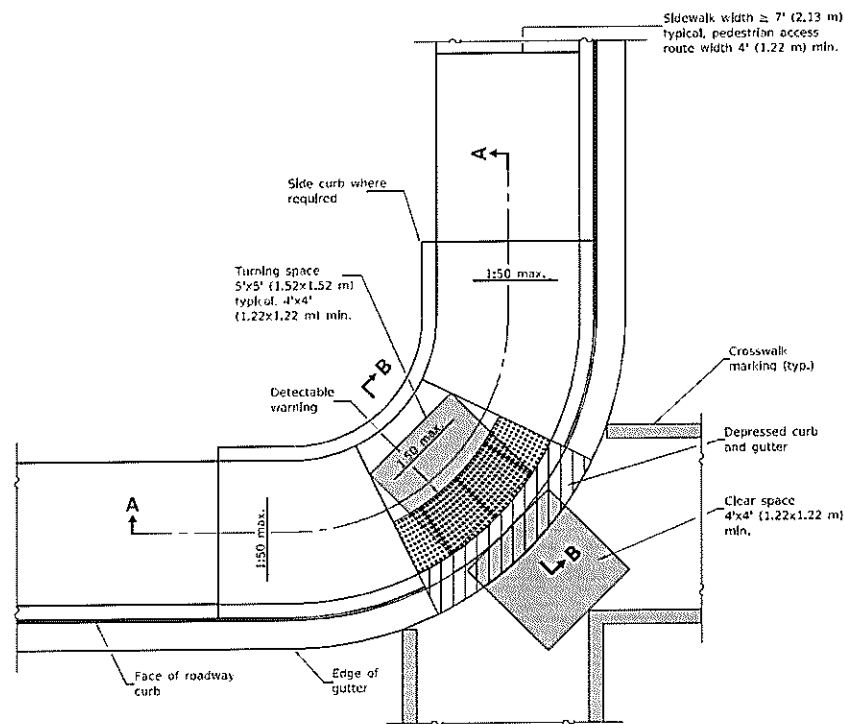

**CORNER PARALLEL CURB RAMP**

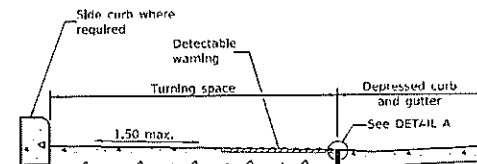

**SECTION B-B**

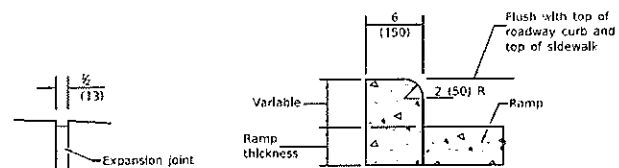

**DETAIL A**

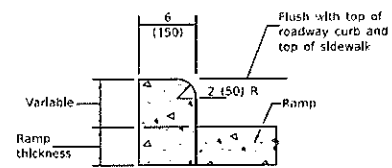

**SIDE CURB DETAIL**

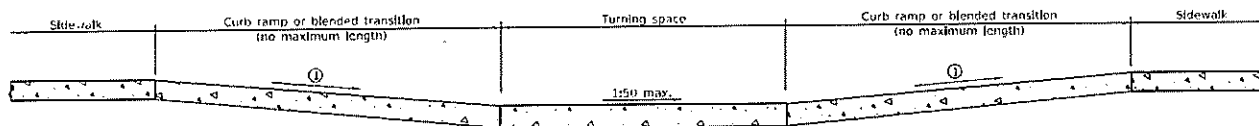

**SECTION A-A**

① The running slope of a curb ramp shall be 1:20 min. and 1:12 max. The running slope of a blended transition shall be 1:20 max.

**GENERAL NOTES**

All slope ratios are expressed as units of vertical displacement to units of horizontal displacement (V:H).

Where the turning space is constrained on a side opposite a ramp, the minimum length of the turning space in the direction of the ramp-run shall be 5' (1.52 m).

Where 1:50 maximum slope is shown, 1:64 is preferred.

Detectable warnings are shown in their ideal locations but the following placement tolerances are allowed.

Side Border - Detectable warnings should extend the full width of the walking surface (excluding flared sides) but a border along each side up to 2 in. (50 mm) in width is allowed.

Curb Set-Back - Detectable warnings located at the back of curb should closely align with the curb but a gap up to 6 in. (150 mm) behind the curb is allowed.

See Standard 606001 for details of depressed curb adjacent to curb ramp.

All dimensions are in inches (millimeters) unless otherwise shown.

DATE	REVISIONS
1-1-19	Removed upper landing, added blended transition and detectable warning tolerances.
1-1-17	Revised sidewalk width to include 24 (610) buffer behind curb.

**CORNER PARALLEL CURB RAMPS FOR SIDEWALKS**

**STANDARD 424011-04**

Illinois Department of Transportation

DESIGNED BY: *M.R.B.* January 1, 2019

ENGINEER OF PLANS AND SPECIFICATIONS

APPROVED: *[Signature]* January 1, 2019

ENGINEER OF DESIGN AND ENVIRONMENT

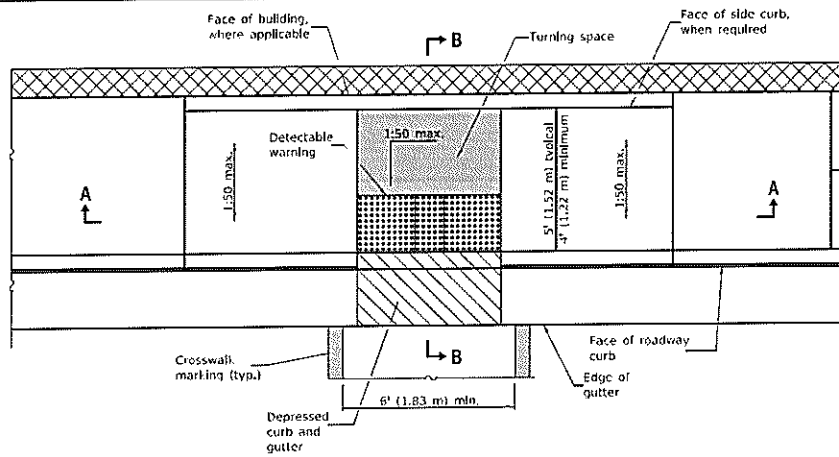

**PARALLEL MID-BLOCK CURB RAMP**

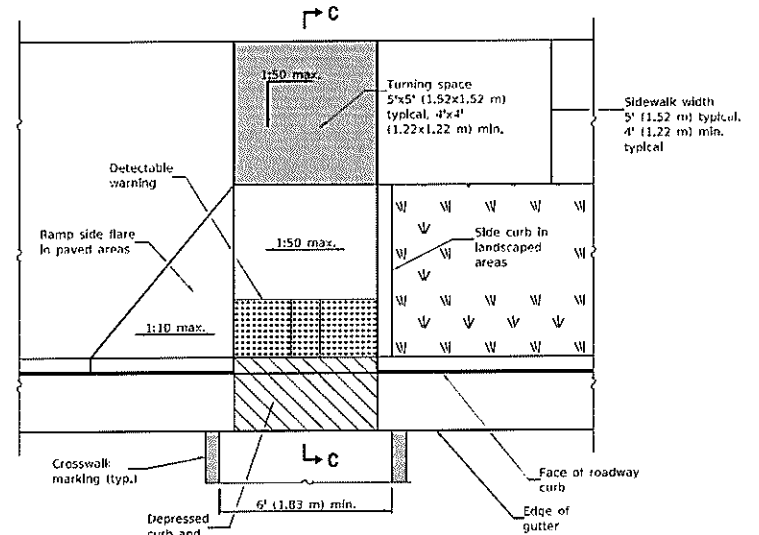

**PERPENDICULAR MID-BLOCK CURB RAMP**

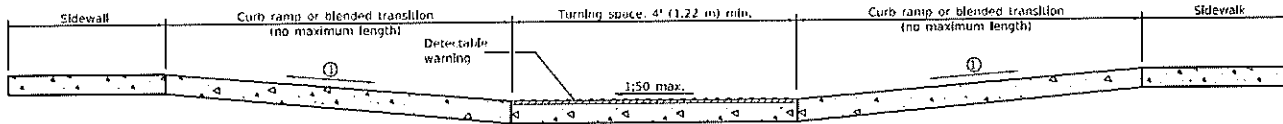

**SECTION A-A**

① The running slope of a curb ramp shall be 1:20 min. and 1:12 max. The running slope of a blended transition shall be 1:20 max.

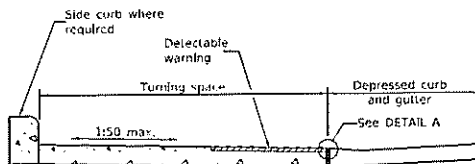

**SECTION B-B**

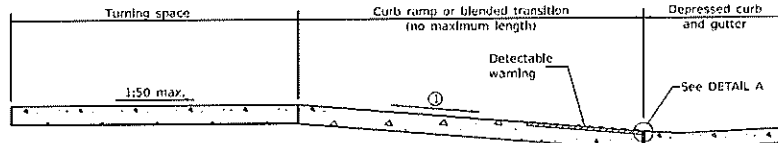

**SECTION C-C**

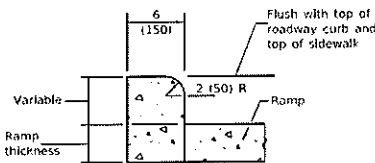

**SIDE CURB DETAIL**

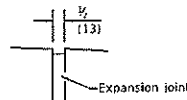

**DETAIL A**

**GENERAL NOTES**

All slope ratios are expressed as units of vertical displacement to units of horizontal displacement (V:H).

Where the turning space is constrained on a side opposite a ramp, the minimum length of the turning space in the direction of the ramp-run shall be 5' (1.52 m).

Where 1:50 maximum slope is shown, 1:64 is preferred.

Detectable warnings are shown in their ideal locations but the following placement tolerances are allowed.

**Side Border** - Detectable warnings should extend the full width of the walking surface (excluding flared sides) but a border along each side up to 2 in. (50 mm) in. width is allowed.

**Curb Set-Back** - Detectable warnings located at the back of curb should closely align with the curb but a gap up to 6 in. (150 mm) behind the curb is allowed.

See Standard 606001 for details of depressed curb adjacent to curb ramp.

All dimensions are in inches (millimeters) unless otherwise shown.

Illinois Department of Transportation  
 PASSED: [Signature] January 1, 2019  
 ENGINEER OF PRACTICE AND PROCEDURES  
 APPROVED: [Signature] January 1, 2019  
 PROJECT OF DESIGN AND ENVIRONMENT

DATE	REVISIONS
1-1-19	Removed upper landing, added blended transitions and detectable warning tolerances.
1-1-18	Omitted diagonal slope at turning spaces and upper landings.

**MID-BLOCK CURB RAMPS FOR SIDEWALKS**

**STANDARD 424016-05**

Sidewalk width 5' (1.52 m) typical, 4' (1.22 m) min.

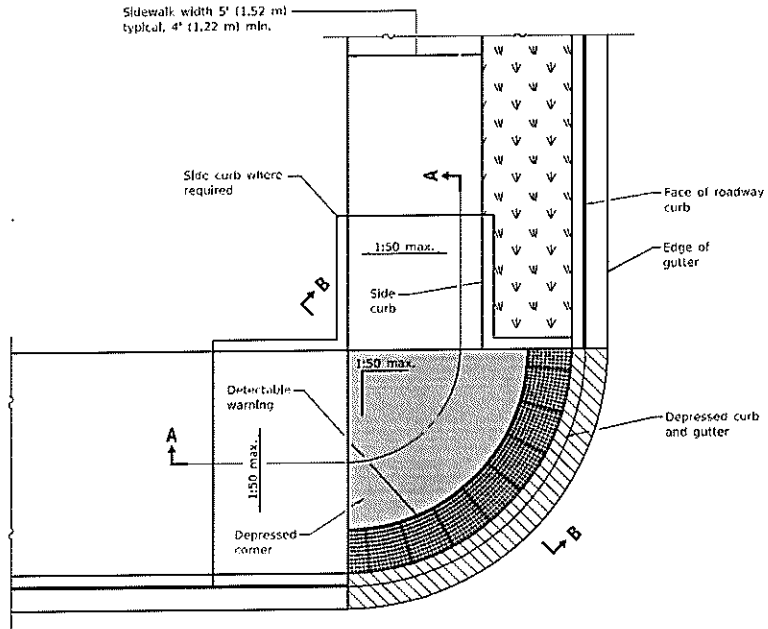

**DEPRESSED CORNER**

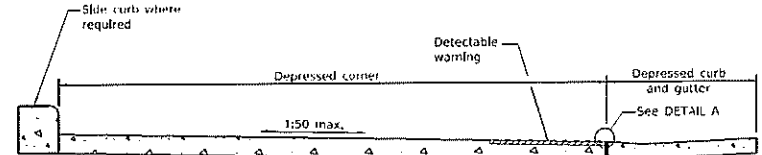

**SECTION B-B**

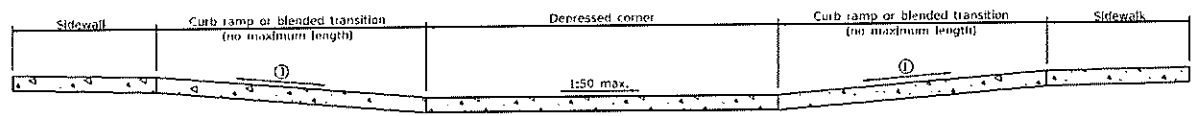

**SECTION A-A**

① The running slope of a curb ramp shall be 1:20 min. and 1:12 max. The running slope of a blended transition shall be 1:20 max.

**GENERAL NOTES**

This standard shall only be used for curb radii of 6 ft. (1.83 m) or greater.

All slope ratios are expressed as units of vertical displacement to units of horizontal displacement (V:H).

Where 1:50 maximum slope is shown, 1:64 is preferred.

Detectable warnings are shown in their ideal tolerances but the following placement tolerances are allowed.

**Side Border** - Detectable warnings should extend the full width of the walking surface (excluding flared sides) but a border along each side up to 2 in. (50 mm) in. width is allowed.

**Curb Set-Back** - Detectable warnings located at the back of curb should closely align with the curb but a gap up to 6 in. (150 mm) behind the curb is allowed.

See Standard 606001 for details of depressed curb adjacent to curb ramp.

All dimensions are in inches (millimeters) unless otherwise shown.

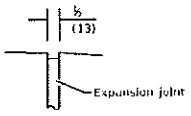

**DETAIL A**

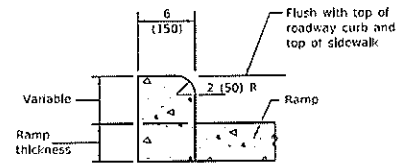

**SIDE CURB DETAIL**

DATE	REVISIONS
1-1-19	Removed upper landings, added blended transition and detectable warning tolerances.
1-1-18	Omitted diagonal slope at turning spaces and upper landings.

**DEPRESSED CORNER FOR SIDEWALKS**

**STANDARD 424021-05**

Illinois Department of Transportation

PROJECT: *424021-05* JANUARY 1, 2019

ENGINEER OF POLLS AND PROCEDURES: *[Signature]*

APPROVED: *[Signature]* JANUARY 1, 2019

ENGINEER OF DESIGN AND ENVIRONMENT

DATE PLOTTED: 01/11/2019

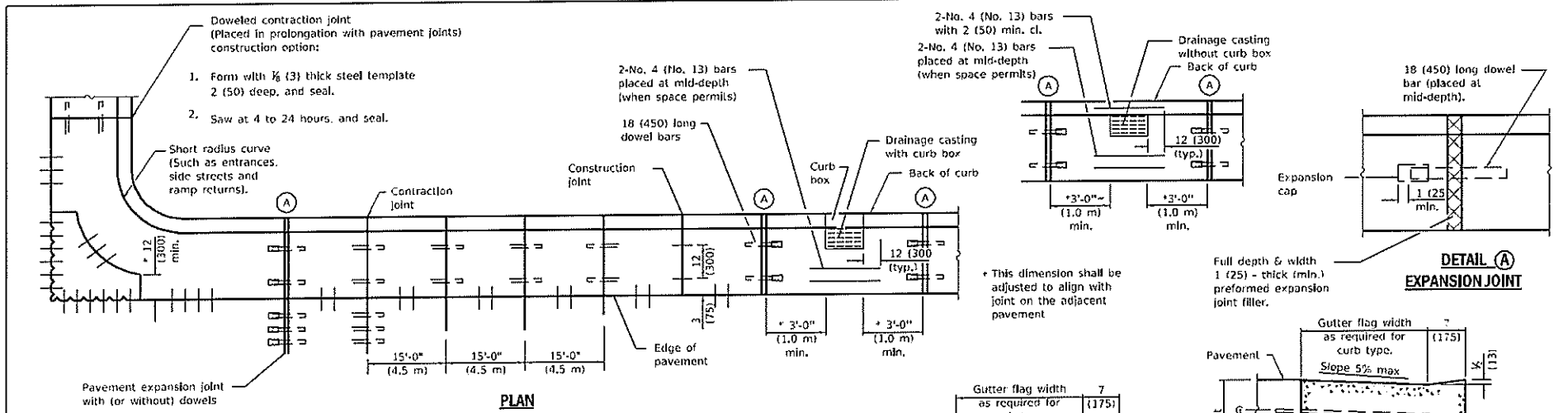

**PLAN**  
**ADJACENT TO PCC PAVEMENT OR PCC BASE COURSE**

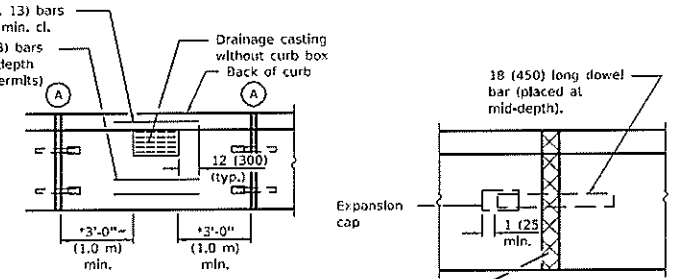

**DETAIL A**  
**EXPANSION JOINT**

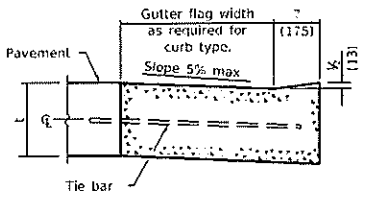

**DEPRESSED CURB ADJACENT TO CURB RAMP ACCESSIBLE TO THE DISABLED**

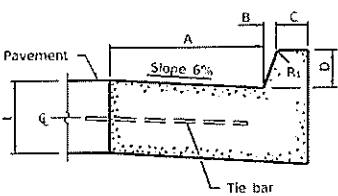

**BARRIER CURB**

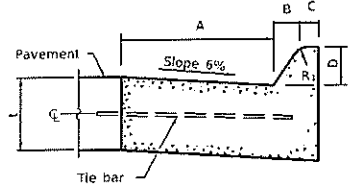

**MOUNTABLE CURB**

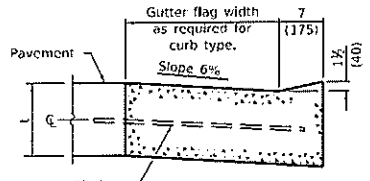

**DEPRESSED CURB (TYPICAL)**

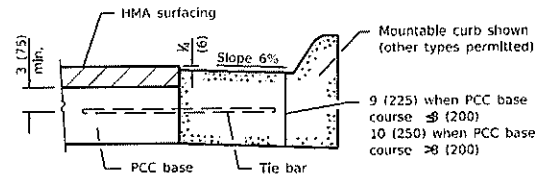

**ADJACENT TO PCC BASE COURSE WITH HMA SURFACING**

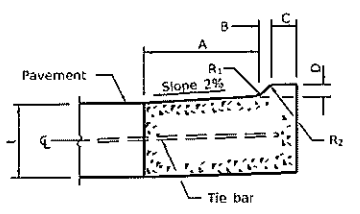

**M-2.06 (M-5.15) and M-2.12 (M-5.30)**

**GENERAL NOTES**

The bottom slope of combination curb and gutter constructed adjacent to pcc pavement shall be the same slope as the subbase or 6% when subbase is omitted.

t = Thickness of pavement.

Longitudinal joint tie bars shall be No. 6 (No. 19) at 36 (900) centers in accordance with details for longitudinal construction joint shown on Standard 420001.

A minimum clearance of 2 (50) between the end of the tie bar and the back of the curb shall be maintained.

The dowel bars shown in contraction joints will only be required for monolithic construction. See Standard 606301 for details of corner islands.

All dimensions are in inches (millimeters) unless otherwise shown.

TYPE	A	B	C	D	R <sub>1</sub>
B-6.06 *	6	1	6	6	1
(B-15.15)	(150)	(25)	(150)	(150)	(25)
B-6.12	12	1	6	6	1
(B-15.3)	(300)	(25)	(150)	(150)	(25)
B-6.18	18	1	6	6	1
(B-15.45)	(450)	(25)	(150)	(150)	(25)
B-6.24	24	1	6	6	1
(B-15.60)	(600)	(25)	(150)	(150)	(25)
B-9.12	12	2	5	9	1
(B-22.30)	(300)	(50)	(125)	(225)	(25)
B-9.18	18	2	5	9	1
(B-22.45)	(450)	(50)	(125)	(225)	(25)
B-9.24	24	2	5	9	1
(B-22.60)	(600)	(50)	(125)	(225)	(25)

\* For corner islands only.

TYPE	A	B	C	D	R <sub>1</sub>	R <sub>2</sub>
M-2.06	6	2	4	2	3	2
(M-5.15)	(150)	(50)	(100)	(50)	(75)	(50)
M-2.12	12	2	4	2	3	2
(M-5.30)	(300)	(50)	(100)	(50)	(75)	(50)
M-4.06	6	4	3	4	3	NA
(M-10.15)	(150)	(100)	(75)	(100)	(75)	NA
M-4.12	12	4	3	4	3	NA
(M-10.30)	(300)	(100)	(75)	(100)	(75)	NA
M-4.18	18	4	3	4	3	NA
(M-10.45)	(450)	(100)	(75)	(100)	(75)	NA
M-4.24	24	4	3	4	3	NA
(M-10.60)	(600)	(100)	(75)	(100)	(75)	NA
M-6.06	6	6	2	6	2	NA
(M-15.15)	(150)	(150)	(50)	(150)	(50)	NA
M-6.12	12	6	2	6	2	NA
(M-15.30)	(300)	(150)	(50)	(150)	(50)	NA
M-6.18	18	6	2	6	2	NA
(M-15.45)	(450)	(150)	(50)	(150)	(50)	NA
M-6.24	24	6	2	6	2	NA
(M-15.60)	(600)	(150)	(50)	(150)	(50)	NA

Illinois Department of Transportation

PACKED: January 1, 2018

ENGINEER OF PORTS AND FACILITIES: *Michael Sweet*

APPROVED: January 1, 2018

DESIGNED BY: *Thomas J. Bales*

PROJECT NO. 17-002 (2017) - ENR06040474

DATE CHG

DATE	REVISIONS
1-1-18	Revised General Note for tie bar spacing to 36 (900) cts.
1-1-15	Added B-6.06 (B-15.15) barrier curb and gutter to table (corner islands only).

**CONCRETE CURB TYPE B AND COMBINATION CONCRETE CURB AND GUTTER**

(Sheet 1 of 2)

**STANDARD 606001-07**

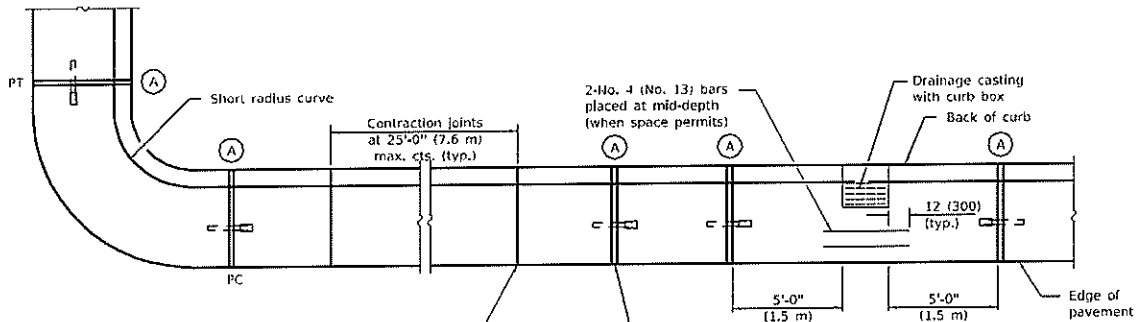

Undoweled contraction joint (typ.) construction options:

1. Form with  $\frac{1}{8}$  (3) thick steel template 2 (50) deep, and seal.
2. Saw 2 (50) deep at 4 to 24 hours, and seal.
3. Insert  $\frac{1}{4}$  (20) thick preformed joint filler full depth and width.

**PLAN**

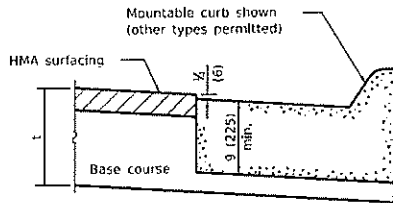

**ON DISTURBED SUBGRADE**

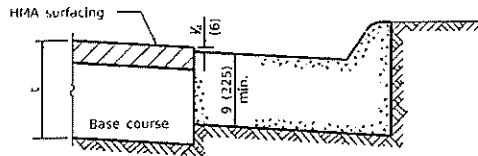

**ON UNDISTURBED SUBGRADE**

**ADJACENT TO FLEXIBLE PAVEMENT**

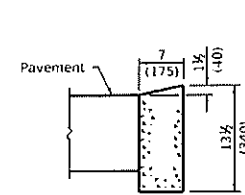

**DEPRESSED CURB**

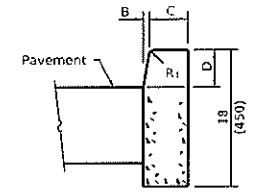

**BARRIER CURB**

**ADJACENT TO FLEXIBLE PAVEMENT**

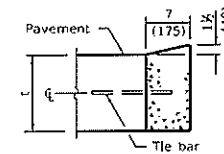

**DEPRESSED CURB**

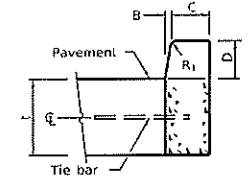

**BARRIER CURB**

**ADJACENT TO PCC PAVEMENT OR PCC BASE COURSE**

**CONCRETE CURB TYPE B**

**CONCRETE CURB TYPE B  
AND COMBINATION  
CONCRETE CURB AND GUTTER**  
(Sheet 2 of 2)

**STANDARD 606001-07**

Illinois Department of Transportation	
PAKAGE	JANUARY 1, 2010
ENGINEER OF PUBLIC WORKS	
APPROVED:	JANUARY 1, 2010
ENGINEER OF PUBLIC WORKS	
PROJECT NO. 06-0300-01	
SHEET NO. 07	

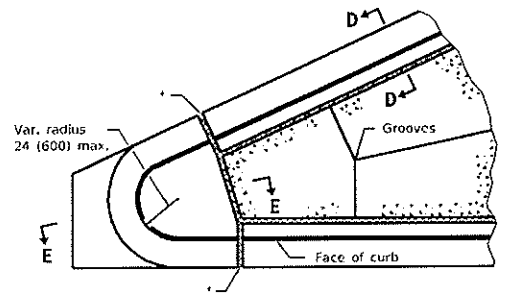
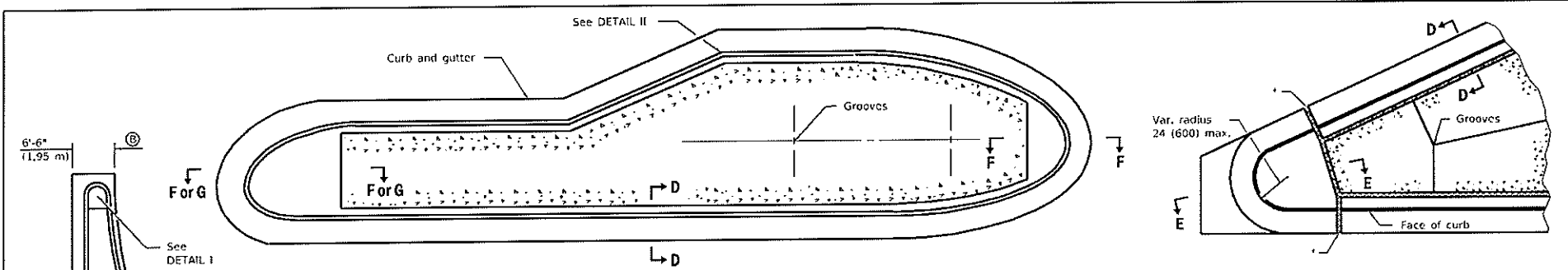

**DETAIL I**

**TYPICAL PLAN OF MEDIAN ISLAND**  
(SEE SHEET 2 FOR DETAILS OF RAMPED NOSES)

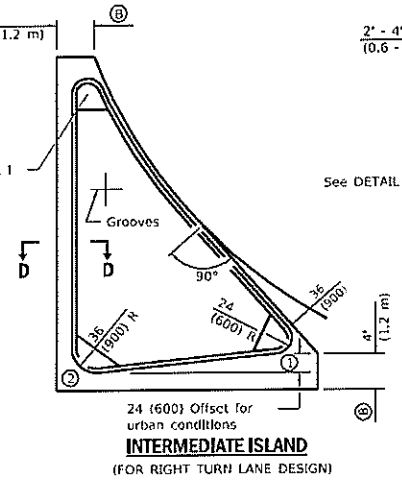
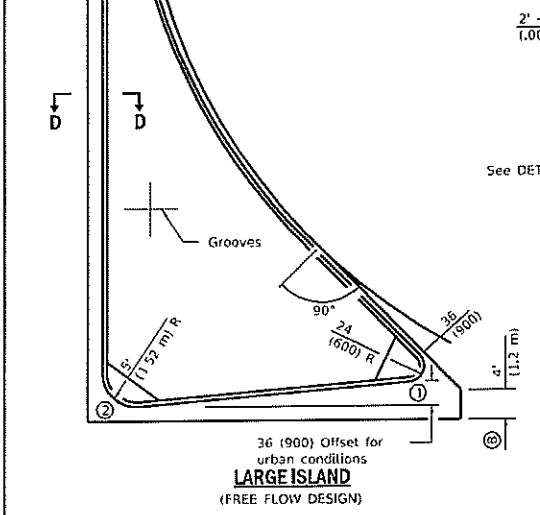

**SMALL ISLAND**

**TYPICAL PLANS OF CORNER ISLANDS**  
(SEE SHEET 2 FOR DETAILS OF RAMPED NOSES)

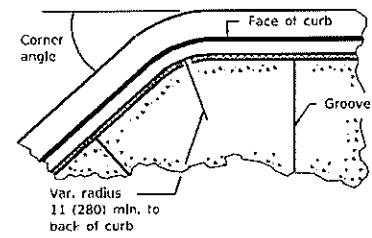

**DETAIL II**

Typical detail when corner angle is less than 90° and for other corners with radius greater than 24 (600).

**NOTE:**  
The blockouts (B) for the islands shall be extended so that the termination will line up with proposed or existing pavement joint.

Noses (1) and (2) shall be ramped unless noted otherwise on the plans. (See sheet 2 for length)

**GENERAL NOTES**

- PEJF = Preformed expansion joint filler.
- Median layout and radii shall be as shown on the plans.
- Keyed longitudinal construction joints shall be constructed without tie bars.
- See Standard 420001 and 606001 for details not shown.
- ¾ (20) PEJF conforming to the full cross section of the curb, gutter and median surface.
- X = PCC base course plus HMA thickness.
- t = Pavement or pcc base course thickness.
- All dimensions are in Inches (millimeters) unless otherwise shown.

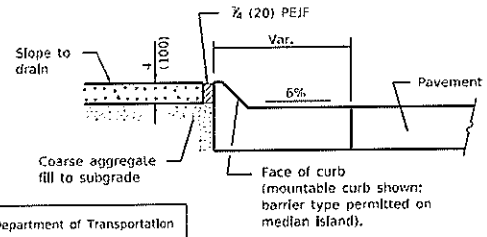

**SECTION D-D**

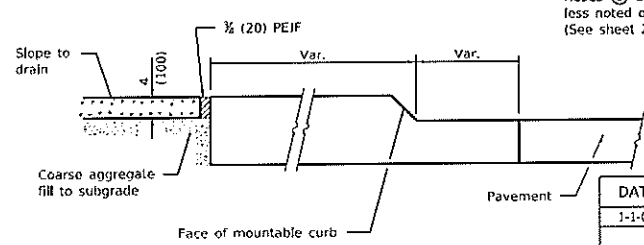

**SECTION E-E**

Illinois Department of Transportation

PROJECT: January 1, 2009

ENGINEER OF SURVEY AND MEASUREMENTS: [Signature]

APPROVER: January 1, 2009

DESIGNER: [Signature]

45111 C 8355E

DATE	REVISIONS
1-1-09	Switched units to English (metric).
1-1-07	Switched to Hot-Mix Asphalt (HMA) terminology.

**PC CONCRETE ISLANDS AND MEDIANS**

STANDARD 606301-04

(Sheet 1 of 2)



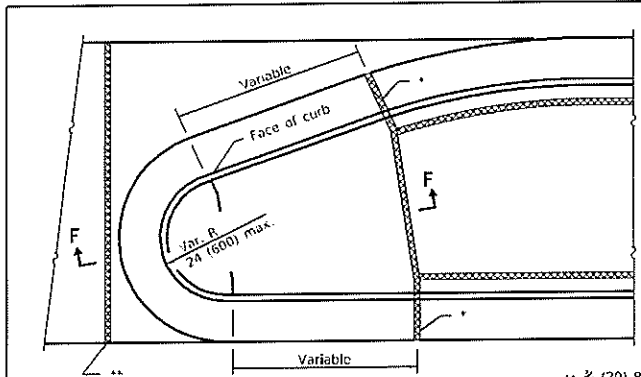

**TYPE P MEDIAN SURFACE**

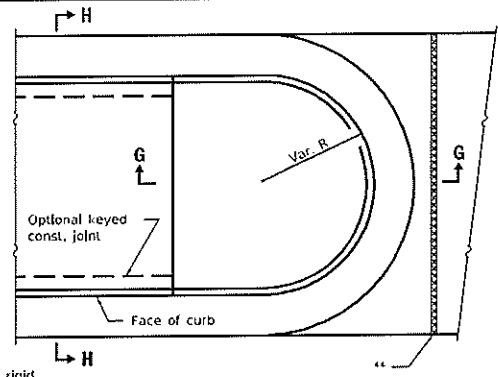

**SOLID MEDIAN**

\*\* 3/4 (20) PEIF between rigid pavement and median end. Align with joint in adjacent pavement.

TABLE OF DIMENSIONS					
TYPE SB MEDIANS					
TYPE	A	B	C	D	R <sub>1</sub>
SB-6.06	6	1	6	6	1
(SB-15.15)	(150)	(25)	(150)	(150)	(25)
SB-6.12	12	1	6	6	1
(SB-15.30)	(300)	(25)	(150)	(150)	(25)
SB-6.18	18	1	6	6	1
(SB-15.45)	(450)	(25)	(150)	(150)	(25)
SB-6.24	24	1	6	6	1
(SB-15.60)	(600)	(25)	(150)	(150)	(25)
SB-9.06	6	2	5	9	1
(SB-22.15)	(150)	(50)	(125)	(225)	(25)
SB-9.12	12	2	5	9	1
(SB-22.30)	(300)	(50)	(125)	(225)	(25)
SB-9.18	18	2	5	9	1
(SB-22.45)	(450)	(50)	(125)	(225)	(25)
SB-9.24	24	2	5	9	1
(SB-22.60)	(600)	(50)	(125)	(225)	(25)

TABLE OF DIMENSIONS					
TYPE M AND SM MEDIANS					
TYPE	A	B	C	D	R <sub>1</sub>
M-2.06	6	2	4	2	2
(M-5.15)	(150)	(50)	(100)	(50)	(50)
M-2.12	12	2	4	2	2
(M-5.30)	(300)	(50)	(100)	(50)	(50)
SM-4.06	6	4	3	4	3
(SM-10.15)	(150)	(100)	(75)	(100)	(75)
SM-4.12	12	4	3	4	3
(SM-10.30)	(300)	(100)	(75)	(100)	(75)
SM-4.18	18	4	3	4	3
(SM-10.45)	(450)	(100)	(75)	(100)	(75)
SM-4.24	24	4	3	4	3
(SM-10.60)	(600)	(100)	(75)	(100)	(75)
SM-6.06	6	6	2	6	2
(SM-15.15)	(150)	(150)	(50)	(150)	(50)
SM-6.12	12	6	2	6	2
(SM-15.30)	(300)	(150)	(50)	(150)	(50)
SM-6.18	18	6	2	6	2
(SM-15.45)	(450)	(150)	(50)	(150)	(50)
SM-6.24	24	6	2	6	2
(SM-15.60)	(600)	(150)	(50)	(150)	(50)

TABLE OF RAMPED NOSE LENGTHS	
TYPE OF NOSE	L
Median	6' (1.8 m)
Small Island	24 (600)
Intermediate Island	4' (1.2 m)
Large Island	6' (1.8 m)

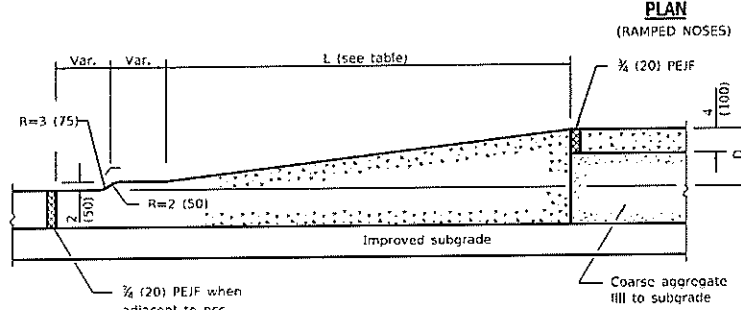

**SECTION F-F**

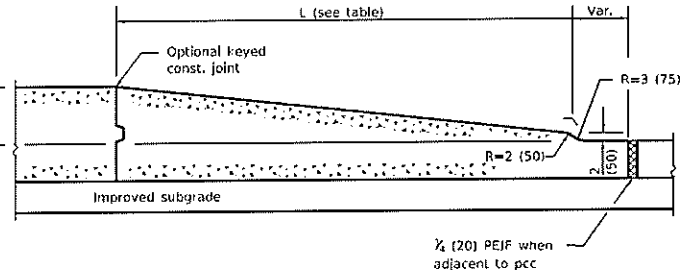

**SECTION G-G**

NOTE  
R<sub>2</sub> is applicable to M-2 (M-5) type only

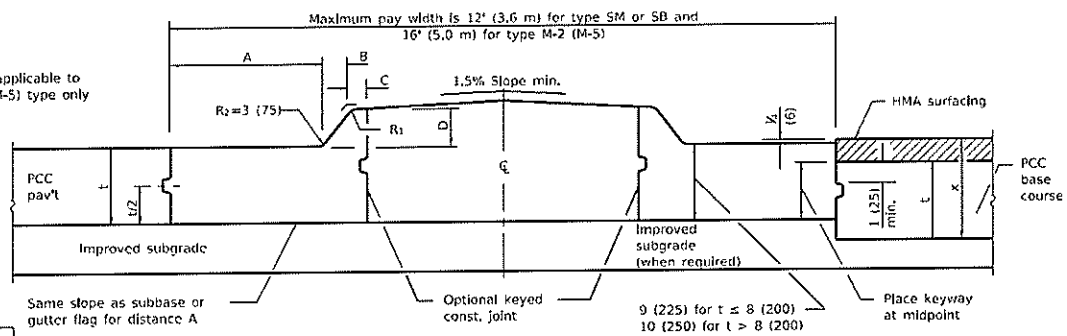

**HALF SECTION FOR PCC PAVEMENT**

**HALF SECTION FOR PCC BASE COURSE**

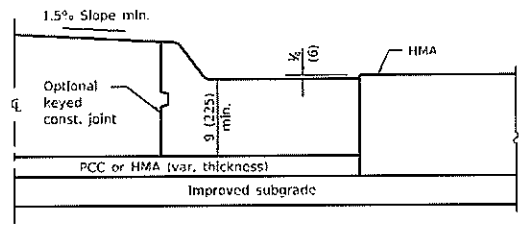

**HALF SECTION FOR FLEXIBLE PAVEMENT**

Illinois Department of Transportation

DESIGNED BY: *[Signature]* January 1, 2009

ENGINEER OF POLY AND PROCEDURES: *[Signature]*

APPROVED BY: *[Signature]* January 1, 2009

44111 C8393

**SECTION H-H**  
(TYPE SM, SB & M-5 (M-2) MEDIANS)

**PC CONCRETE ISLANDS AND MEDIANS**

(sheet 2 of 2)

**STANDARD 606301-04**

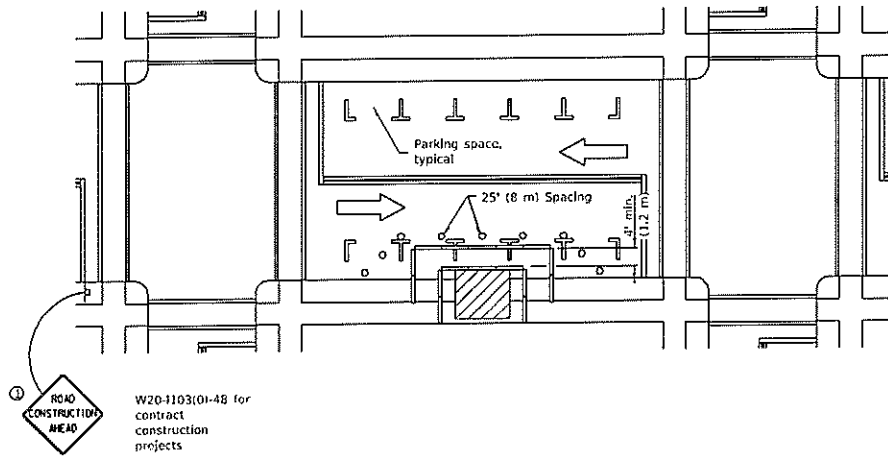

① ROAD CONSTRUCTION AHEAD W20-1103(01)-48 for contract construction projects

Or

① ROAD WORK AHEAD W20-1101-48 for maintenance and utility projects

**SIDEWALK DIVERSION**

- SYMBOLS**
- Work area
  - Sign on portable or permanent support
  - Barricade or drum
  - Cone, drum or barricade
  - Type III barricade
  - Detectable pedestrian channelizing barricade

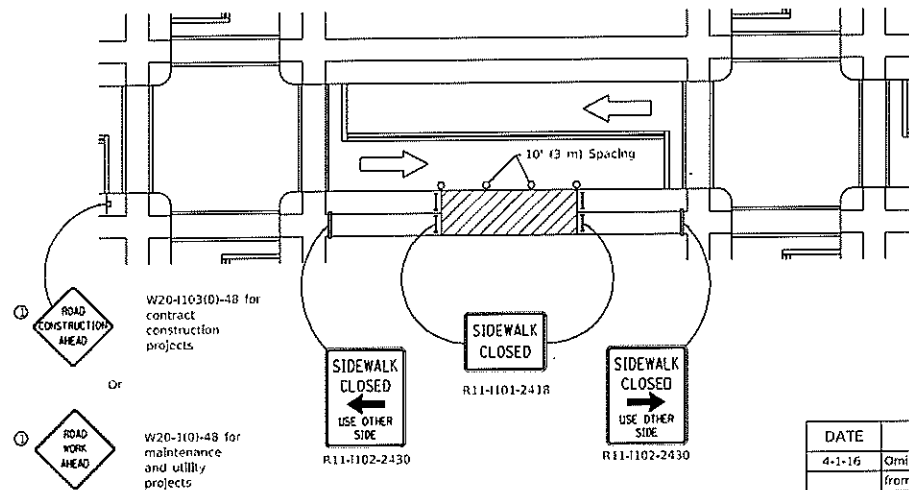

① ROAD CONSTRUCTION AHEAD W20-1103(01)-48 for contract construction projects

Or

① ROAD WORK AHEAD W20-1101-48 for maintenance and utility projects

**SIDEWALK CLOSURE**

① Omit whenever duplicated by road work traffic control.

**GENERAL NOTES**

This Standard is used where, at any time, pedestrian traffic must be rerouted due to work being performed.

This Standard must be used in conjunction with other Traffic Control & Protection Standards when roadway traffic is affected.

Temporary facilities shall be detectable and accessible.

The temporary pedestrian facilities shall be placed on the same side of the closed facilities whenever possible.

The SIDEWALK CLOSED / USE OTHER SIDE sign shall be placed at the nearest crosswalk or intersection to each end of the closure. Where the closure occurs at a corner, the signs shall be erected on the corners across the street from the closure. The SIDEWALK CLOSED signs shall be used at the ends of the actual closures.

Type III barricades and R11-2-4830 signs shall be positioned as shown in "ROAD CLOSED TO ALL TRAFFIC" detail on Standard 701901.

All dimensions are in inches (millimeters) unless otherwise shown.

DATE	REVISIONS
4-1-16	Omitted orange safety fence from standard as this is covered in the std. spec.
1-1-12	Added SIDEWALK DIVERSION. Modified appearance of plan views. Renamed Std.

**SIDEWALK, CORNER OR CROSSWALK CLOSURE**

(Sheet 1 of 2)

**STANDARD 701801-06**

Illinois Department of Transportation

PAK/SPB *Edie L.* 7016

ENGINEER OF SAFETY ENGINEERING

APPROVED *Edie L.* 7016

45771 C/MS/SP

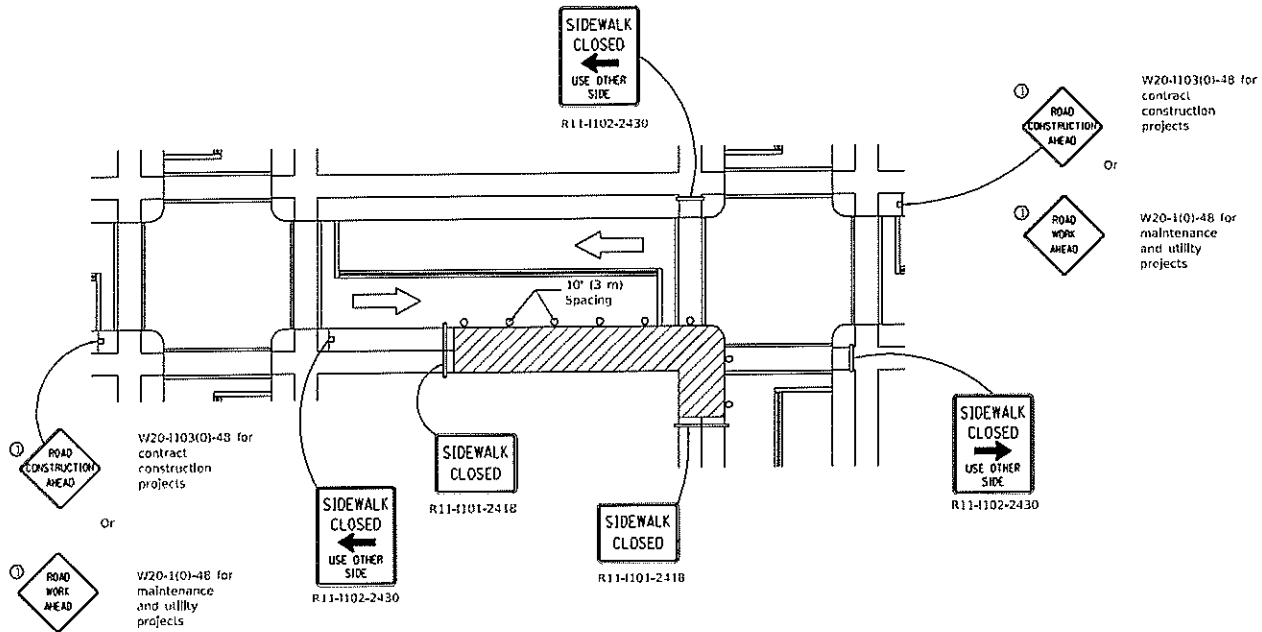

**CORNER CLOSURE**

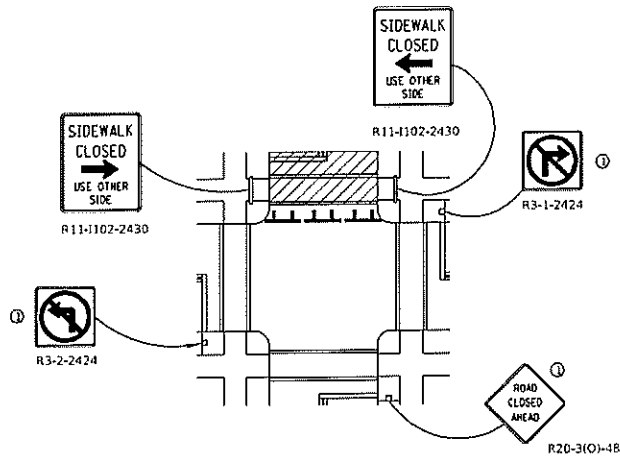

**CROSSWALK CLOSURE**

**SIDEWALK, CORNER OR CROSSWALK CLOSURE**

(Sheet 2 of 2)

STANDARD 701801-06

Illinois Department of Transportation	
DESIGNED BY: <i>[Signature]</i> 7016 ENGINEER OF SAFETY ENGINEERING	CHECKED BY: <i>[Signature]</i> 701A ENGINEER OF SAFETY ENGINEERING
APPROVED BY: <i>[Signature]</i> 701A ENGINEER OF SAFETY ENGINEERING	

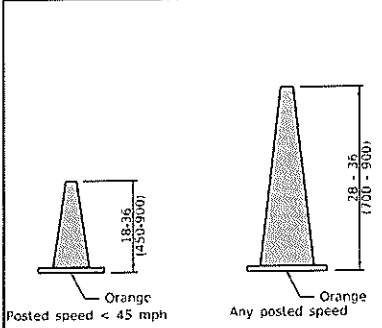

**DAYTIME USE**

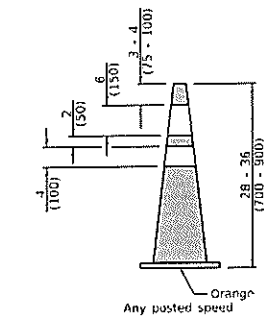

**DAY OR NIGHTTIME USE**

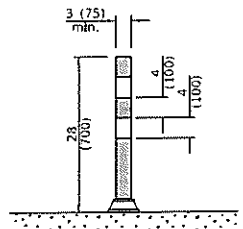
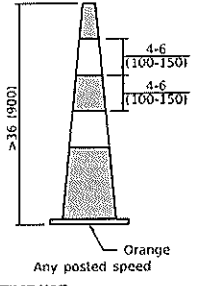

**TUBULAR MARKER**

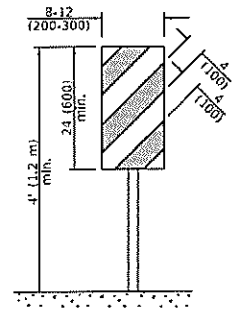

**VERTICAL PANEL POST MOUNTED**

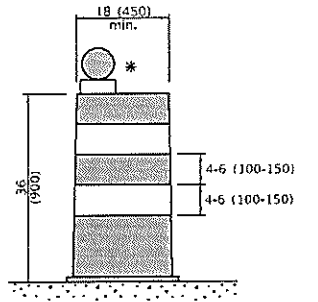

**DRUM**

**CONES**

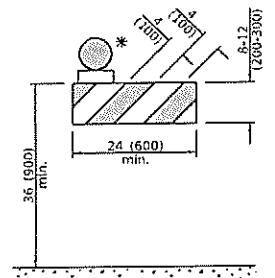

**TYPE I BARRICADE**

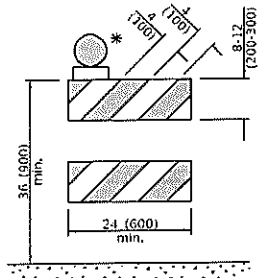

**TYPE II BARRICADE**

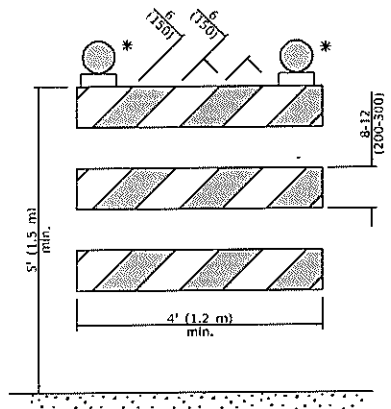

**TYPE III BARRICADE**

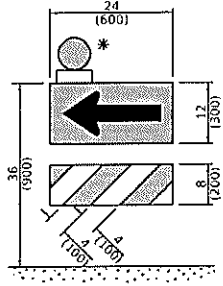

**DIRECTION INDICATOR BARRICADE**

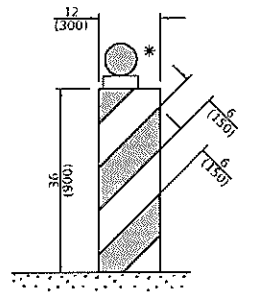

**VERTICAL BARRICADE**

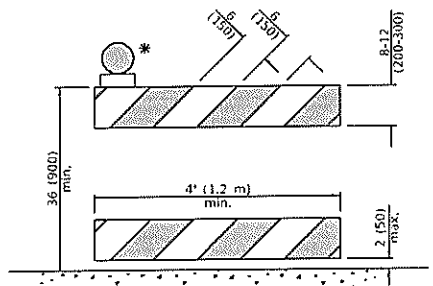

**DETECTABLE PEDESTRIAN CHANNELIZING BARRICADE**

\* Warning lights (if required)

**GENERAL NOTES**

All heights shown shall be measured above the pavement surface.  
All dimensions are in inches (millimeters) unless otherwise shown.

Illinois Department of Transportation

APPROVED: *Carmen Out* January 1, 2019  
ENGINEER OF SAFETY PROC. AND ENGINEERING

APPROVED: *[Signature]* January 1, 2019  
ENGINEER OF DESIGN AND CONSTRUCTION

DATE	REVISIONS
1-1-19	Revised cone usage and added cones >36" (900 mm) height.
1-1-18	Revised END WORK ZONE SPEED LIMIT sign from orange to white background.

**TRAFFIC CONTROL DEVICES**

STANDARD 701901-08

(Sheet 1 of 3)

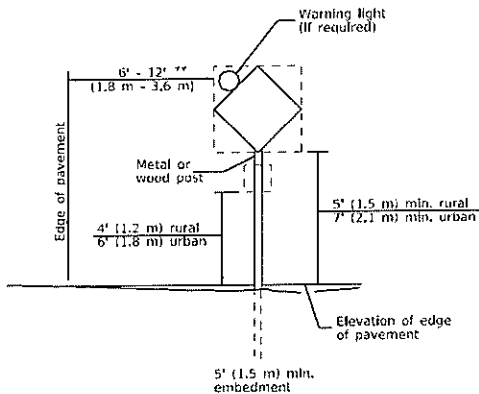

**POST MOUNTED SIGNS**

\*\*\* When curb or paved shoulder are present this dimension shall be 24 (600) to the face of curbs or 6' (1.8 m) to the outside edge of the paved shoulder.

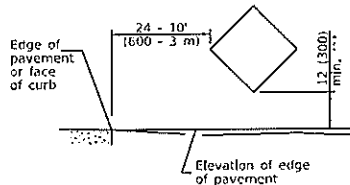

**SIGNS ON TEMPORARY SUPPORTS**

\*\*\* When work operations exceed four days, this dimension shall be 5' (1.5 m) min. If located behind other devices, the height shall be sufficient to be seen completely above the devices.

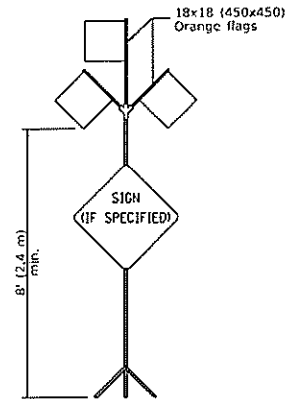

**HIGH LEVEL WARNING DEVICE**

**ROAD CONSTRUCTION NEXT X MILES**

G20-1104(0)-6036

**END CONSTRUCTION**

G20-1105(0)-6024

This signing is required for all projects 2 miles (3200 m) or more in length.

ROAD CONSTRUCTION NEXT X MILES sign shall be placed 500' (150 m) in advance of project limits.

END CONSTRUCTION sign shall be erected at the end of the job unless another job is within 2 miles (3200 m).

Dual sign displays shall be utilized on multi-lane highways.

**WORK LIMIT SIGNING**



W21-III(0)-3618

R2-1-3648

R10-108p-3618 \*\*\*\*

R2-1106p-3618

Sign assembly as shown on Standards or as allowed by District Operations.

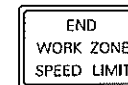

G20-1103-6036

This sign shall be used when the above sign assembly is used.

**HIGHWAY CONSTRUCTION SPEED ZONE SIGNS**

\*\*\*\* R10-108p shall only be used along roadways under the jurisdiction of the State.

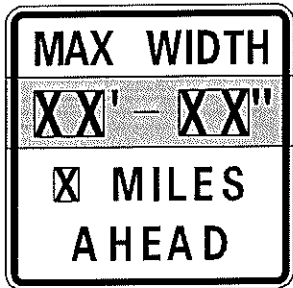

W12-1103-4848

**WIDTH RESTRICTION SIGN**

XX'-XX" width and X miles are variable.

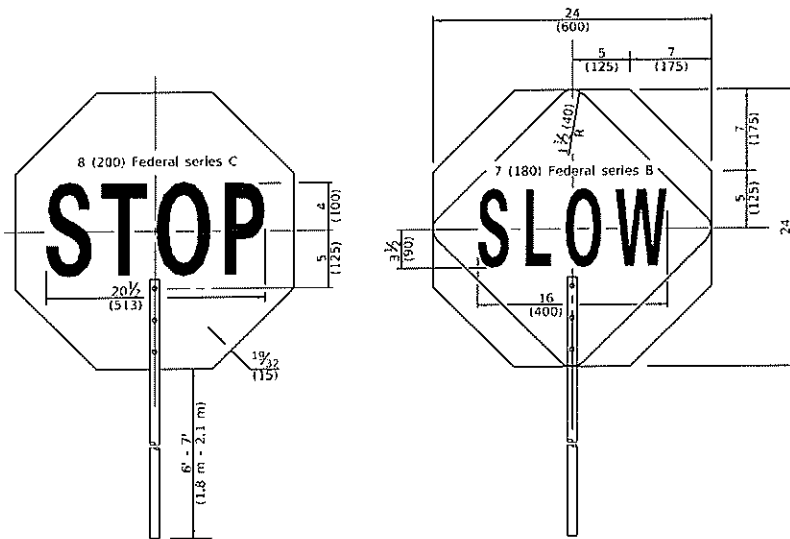

FRONT SIDE

REVERSE SIDE

**FLAGGER TRAFFIC CONTROL SIGN**

Illinois Department of Transportation

APPROVED: *[Signature]* Monday, 1/1/2019  
 ENGINEER OF SAFETY PROG. AND ENGINEERING

APPROVED: *[Signature]* January 1, 2019  
 ENGINEER OF THE STATE DEPARTMENT

ELC: CMPS

**TRAFFIC CONTROL DEVICES**

(Sheet 2 of 3)

**STANDARD 701901-08**

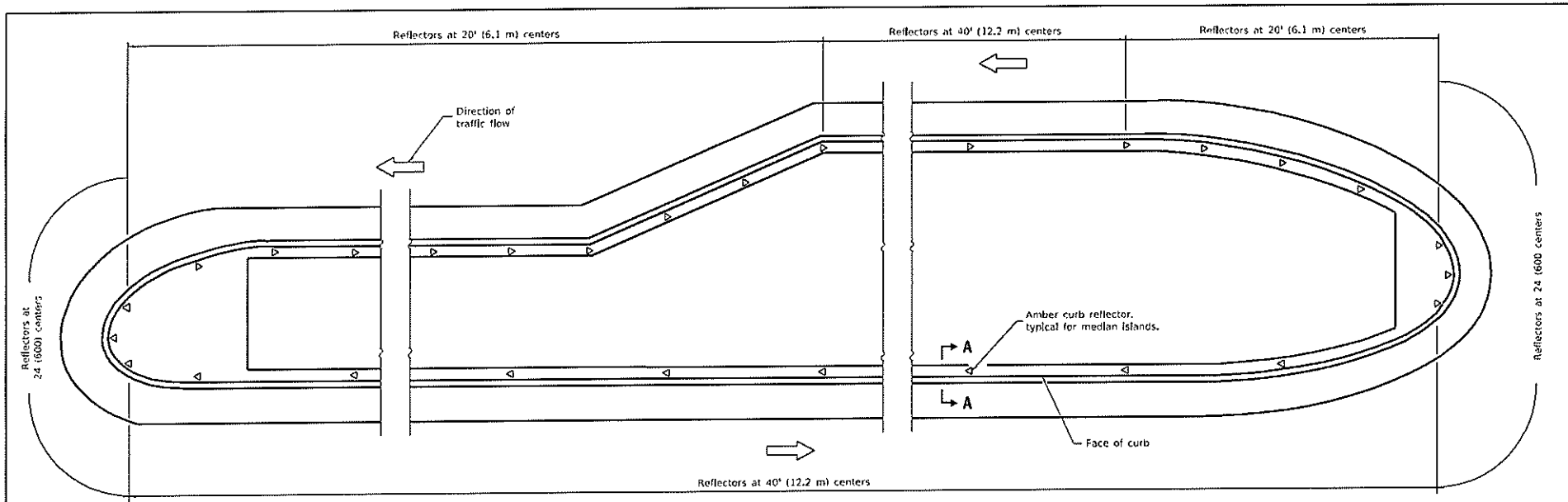

**MEDIAN ISLAND**

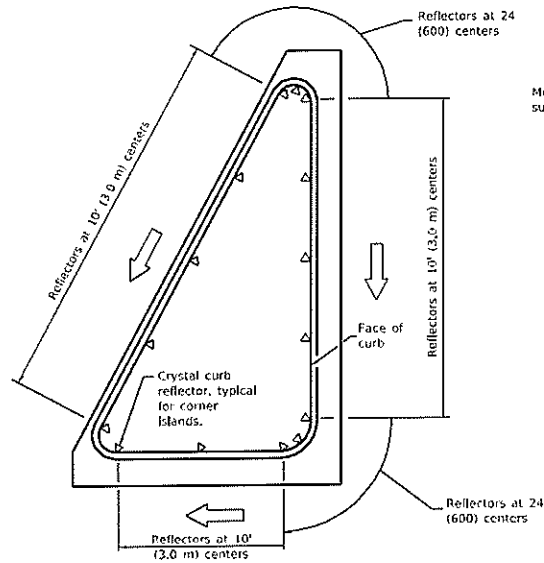

**CORNER ISLAND**

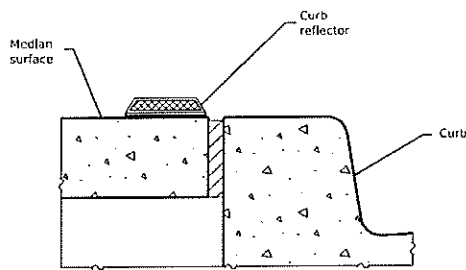

**SECTION A-A**  
(Similar for corner islands.)

**GENERAL NOTES**

Curb reflectors shall be unidirectional and oriented with the reflective face toward approaching traffic.

All dimensions are in inches (millimeters) unless otherwise shown.

Illinois Department of Transportation

PROJECT: \_\_\_\_\_ DATE: 7/16

ENGINEER OF OPERATIONS: *John Miller*

APPROVED: *[Signature]* DATE: 7/16

DESIGNED BY: \_\_\_\_\_

DATE	REVISIONS
1-1-16	Revised title and removed work 'prismatic'.
1-1-12	New standard.

<b>CURB REFLECTORS</b>
<b>STANDARD 782001-01</b>

## PREVAILING WAGES

This Contract shall be subject to the provisions of the *Prevailing Wage Act* (820 ILCS 130/1 et seq.) to the extent required by law.

For Prevailing Wage information please go to the City of Joliet Website

<http://cityofjoliet.info/departments/finance/purchasing/prevailing-wage-information>.

For current Prevailing Wage Rates, go to State of Illinois Website below and follow the instructions:

<https://data.illinois.gov/dataset/id-2018-prevailing-wage-rates/resource/0c95f063-aed9-4db7-adc3-c224acee8fc2>

If you cannot access or have difficulty retrieving the prevailing wage information, contact [purchasing@joliet.gov](mailto:purchasing@joliet.gov) call 815-724-3926 and we will send you the relevant prevailing wage information.

## NOTICE

The City of Joliet has adopted the Responsible Bidder Ordinance. In addition to any other requirement, unless otherwise expressly stated in a bid solicitation or an award of contract, all bidders must comply with the following requirements in order to submit a bid or be awarded a contract and include satisfactory evidence thereof in its bid.

(1) The bidder must be a duly organized legal entity in good standing with the Illinois Secretary of State and in compliance with all laws prerequisite to doing business in Illinois.

(2) The bidder must have a valid Federal Employer Tax Identification Number or Social Security Number.

(3) The bidder must be an equal opportunity employer and comply with Section 2000(e) of Chapter 21, Title 42 of the United States Code and Executive Order No. 11246.

(4) The bidder shall provide certificates of insurance indicating the following coverages if called for in the bid solicitation: general liability, workers compensation, completed operations, automobile, hazardous occupation and product liability.

(5) The bidder must comply with all provisions of the Illinois Prevailing Wage Act (820 ILCS 130), including wages, medical and hospitalization insurance and retirement for those trades covered in the Act.

(6) All contractors and sub-contractors performing services covered by the Illinois Prevailing Wage Act must submit to the City the certified payrolls required by the Act, as amended by Illinois Public Act 94-0515.

(7) For construction projects (construction of new facilities, renovation of existing facilities or road construction projects) over \$25,000.00, or demolition contracts over \$25,000.00, the bidder must provide apprenticeship and training programs that are either registered with the United States Department of Labor's Bureau of Apprenticeship and Training or are reasonably equivalent to such programs.

**Margaret E. McEvilly**  
Purchasing / Contracts Administrator



## **PREVAILING WAGES**

This Contract shall be subject to the provisions of the *Prevailing Wage Act* (820 ILCS 130/1 et seq.) to the extent required by law.

For Prevailing Wage information please go to the City of Joliet Website

<https://www.joliet.gov/departments/finance/purchasing/prevailing-wage-information>

For current Prevailing Wage Rates, go to State of Illinois Website below and follow the instructions:

<https://data.illinois.gov/dataset/idol-2018-prevailing-wage-rates/resource/0c95f063-aed9-4db7-adc3-c224acee8fc2>

If you cannot access or have difficulty retrieving the prevailing wage information, contact Margaret McEvilly at [mmcevilly@joliet.gov](mailto:mmcevilly@joliet.gov) or call 815-724-3926 and we will send you the relevant prevailing wage information.

**DEPARTMENT OF  
PUBLIC WORKS**

815-724-4200 Direct  
815-723-7770 Fax

**CITY OF**



**JOLIET**

GENERAL CONTRACTOR

RE: 2020 CONSTRUCTION PROJECTS

**150 WEST JEFFERSON STREET  
JOLIET, ILLINOIS 60432-4158**

Dear General Contractor:

The City of Joliet currently has specifications, which require ten **(10%)** percent minority participation in contracts over \$100,000.00. In an effort to track this information letter, the City of Joliet will be requiring all GENERAL CONTRACTS to submit to a complete list of sub-contractors they intend to use on the awarded project at the pre-construction meeting. The issuance of this sub-contractor list will help the City ensure that minority requirements are met as well as prevailing wages. The sub-contractor list should include the dollar amount or percentage of this contract for the work the sub-contractor is responsible. I.D.O.T. for BC 260-A is an example of such an acceptable form. In addition, the specification states that monthly certified payroll records are to be submitted to the Engineer. This will also be enforced for the upcoming construction season.

The City of Joliet appreciates your effort throughout the years and looks forward to working with you in the upcoming construction season.

A handwritten signature in cursive script that reads 'James R. Trizna'.

James R. Trizna  
Public Works Director

A handwritten signature in cursive script that reads 'Allison Swisher'.

Allison Swisher  
Director of Public Utilities

## **NOTICE TO BIDDERS – ETHICS ORDINANCE AND INSPECTOR GENERAL COMPLIANCE**

The City of Joliet has an Ethics Ordinance (Section 2-333 et seq. of the Code of Ordinances of the City of Joliet) which prohibits any appointed or elected official of the City of Joliet, or any employee of the City of Joliet from receiving or soliciting anything of value to influence that City official or employee in carrying out his or her official duties. The City of Joliet appreciates your anticipated cooperation in refraining from offering any official or employee any thing, item, service, or favor of value to influence that person's decision on any City business. With your cooperation, the City of Joliet will achieve its goal of maintaining a fair and competitive contract procedure that promotes the best interests of the citizens of the City of Joliet. You should report immediately any violation of the Ethics Ordinance to the Inspector General, including any solicitation of a thing of value by a City official or employee. A bidder or contractor's participation or encouragement in the violation of the Ethics Ordinance may result in the rejection of a bid, termination of contract, or declaration of ineligibility to bid on future contracts.

It is the duty of any bidder, proposer, consultant, subcontractor, applicant for pre-qualification for a City contract, applicant for local bidder certification, and all officers, directors, agents, partners and employees of any bidder, proposer, consultant, subcontractor, or such applicant to cooperate with the Inspector General in any investigation or hearing undertaken pursuant to City of Joliet Ordinance 2-180, et. seq.. Any of the aforementioned parties understands and will abide by all provisions of the aforementioned Ordinance. All contractors must inform subcontractors of the provision and require understanding and compliance with it.

A copy of the City of Joliet Ethics Ordinance and all other City Ordinances are available in the City Clerk's office or on the City website for your review.

CITY OF JOLIET  
STATE OF ILLINOIS

PROPOSAL FORM

NOTE: ALL BLANKS ON EACH AND EVERY SHEET OF THIS PROPOSAL SHALL BE COMPLETED. FAILURE TO COMPLETE ALL BLANKS SHALL BE GROUNDS FOR REJECTION OF BIDS.

TO THE MAYOR AND CITY COUNCIL OF JOLIET, ILLINOIS:

1. PROPOSAL OF \_\_\_\_\_  
(Name and Address of Bidder)

2. The plans for the proposed work are those prepared by the City Engineer and approved by the City Council of the City of Joliet, Illinois on \_\_\_\_\_.

The specifications herein referred to are those prepared by the City Engineer.

3. In submitting this proposal, the undersigned declares that the only persons or parties interested in the proposal as principals are those named herein; and that the proposal is made without collusion with any other person, firm, or corporation.

4. The undersigned further declares that he has carefully examined the proposal, plans, specifications, form of contract and contract bond, and special provisions, and that he has inspected in detail the site of the proposed work, and that he has familiarized himself with all of the local conditions affecting the contract and the detailed requirements of construction, and he understands that in making this proposal he waives all right to plead any misunderstanding regarding the same.

5. The undersigned further understands and agrees that if this proposal is accepted he is to furnish and provide all necessary machinery, tools, apparatus, and other means of construction, in the respective sections, and to do all of the work, and to furnish all of the materials specified in the contract.

6. The undersigned declares that he understands that the quantities mentioned are approximate only and that they are subject to increase or decrease; that he will take in full payment therefore the amount and the summation of the actual quantities, as finally determined multiplied by the unit price shown in the schedule of prices contained herein.

7. The undersigned further agrees that the unit prices submitted herewith are for the purpose of obtaining a gross sum, and for use in computing the value of extras and deduction; that if there is a discrepancy between the gross sum bid and that resulting from the summation of the quantities multiplied by their respective unit prices, the latter shall apply.

8. The undersigned further agrees that if the owner decides to extend or shorten improvement, or otherwise alter it by extras or deductions, including the

elimination of any one or more of the items, by an amount not to exceed twenty-five (25) percent of the total money value of the original contract price or contract price corrected as provided in the specifications, he will perform the work as altered, increased or decreased at the contract unit price.

9. The undersigned further agrees that the Engineer may at any time during the progress of the work covered by this contract, order other materials as do not appear in the proposal or contract as a specific item accompanied by a unit price, and which are not included under the bid price for other items in this contract, shall be performed as extra work, and that he will accept as full compensation therefore the actual cost plus fifteen percent (15%), the actual cost to be determined as provided in the specification.
10. The undersigned further agrees to execute a contract for this work and present the same to the City of Joliet within fifteen (15) days after the date of the notice of the award of the contract to him.
11. The undersigned further agrees that he and his surety will execute and present within fifteen (15) days after the date of the notice of the award of the contract, a contract bond satisfactory to and in the form prescribed by the City of Joliet in the penal sum of one hundred percent (100%) of the full amount of the contract within the terms of the contract.
12. The undersigned further agrees to begin work not later than ten (10) days after the execution of the acceptance of the contract and contract bond, unless otherwise provided and to prosecute the work in such manner and with sufficient materials, equipment, and labor as will insure its completion within the time limit specified herein, it being understood and agreed that the completion within the time limit is an essential part of the contract. The undersigned agrees to complete the work within **30 consecutive working days** after execution of the contract, by both parties, unless additional time shall be granted by the Engineer in accordance with provisions of the specifications.

In case of failure to complete the work in or before the time named herein or within such extra time as may have been allowed by extensions, the undersigned agrees that the City of Joliet shall withhold, from each sum as may be due him under the terms of this contract, the costs, set forth in the specifications of the contract, which costs shall be considered and treated not as a penalty but as damages due to the City of Joliet from the undersigned by reason on inconvenience to the public, added cost of engineering and supervision and other items which have caused an expenditure of public funds resulting from the failure of the under signed to complete the work within the time specified in the contract.

13. Accompanying this proposal is a bank draft, bank cashier's check, bid bond or a certified check, complying with the requirements of the specifications, made payable to the City of Joliet.

THE AMOUNT OF THE CHECK OR DRAFT IS (\$ \_\_\_\_\_)

\_\_\_\_\_

If this proposal is accepted and the undersigned shall fail to execute a contract and contract bond as required within, it is hereby agreed that the amount of the check or bank draft shall become the property of the City of Joliet and shall be considered as payment of damages due to delay and other causes suffered by the City of Joliet because of the failure to execute said contract and contract bond; otherwise said check or draft, shall be returned to the undersigned.

14. The undersigned submits herewith his schedule of prices covering the work to be performed under this contract; he understands that he must show in the schedule of unit prices for which he proposes each item of work, that the extensions must be made by him and that if not so done his proposal may be rejected as irregular.
15. All bidders must furnish current financial statement with the bid.
16. All bidders must furnish a list of equipment available for and to be use on this project with their bid.

**CITY OF JOLIET  
SCHEDULE OF PRICES**

ITEM NO	ITEM DESCRIPTION	QUANTITY	UNITS	UNIT PRICE	COST
NO. 1	P.C.C. SIDEWALK, 5"	6800	SQ FT		
NO. 2	CONCRETE CURB & GUTTER	615	LN FT		
NO. 3	P.C.C. DRIVEWAY PAVEMENT, 6"	15	SQ YD		
NO. 4	BUFFALO BOX/ VALVE BOX ADJUSTMENT	1	EACH		
NO. 5	HOT MIX ASPHALT REMOVAL & REPLACEMENT, 3"	40	SQ YD		
NO. 6	DELINEATOR POST TO BE INSTALLED	5	EACH		
NO. 7	CURB REFLECTORS	16	EACH		
NO. 8	POROUS GRANULAR BACKFILL	111	SQ YD		
NO. 9	PROTECTIVE COAT	1050	SQ YD		
NO. 10	DETECTABLE WARNINGS	58	SQ FT		
NO. 11	CONCRETE REMOVAL ONLY/ RESTORATION WITH 5" TOPSOIL & SEED W/EROSION CONTROL BLANKET	25	SQ FT		
NO. 12	REMOVAL AND DISPOSAL OF CONTAMINATED MATERIAL	5	CU YD		
NO. 13	TREE ROOT GRINDING- 8" DIAMETER AND GREATER	12	EACH		
no. 14	TREE FRAME & GRATE TO BE REMOVED AND RE-INSTALLED	3	EACH		
no. 15	BRICK PAVER REMOVAL & REINSTALLATION	140	SQ FT		
no. 16	SEAL AND ADJUST MANHOLE FRAME (NON-PAVED)	1	L SUM		
no. 17	CONCRETE MEDIAN- TYPE SB-6.12	305	SQ FT		
no. 18	CONCRETE MEDIAN SURFACE- 15"	103	SQ FT		
no. 19	CONCRETE MEDIAN SURFACE- 4"	1615	SQ FT		
no. 20	RAILROAD PROTECTIVE LIABILITY INSURANCE	1	L SUM		

BIDDER'S PROPOSAL FOR IMPROVEMENTS:

CONTRACTOR NAME: \_\_\_\_\_  
 ADDRESS: \_\_\_\_\_  
 CITY/STATE/ ZIP: \_\_\_\_\_  
 TEL NO.: \_\_\_\_\_  
 EMAIL ADDRESS: \_\_\_\_\_

18. This set of contract documents shall remain intact and shall be submitted in its entirety with the proposal.

(IF AN INDIVIDUAL)

SIGNATURE OF BIDDER \_\_\_\_\_ (SEAL)

BUSINESS ADDRESS \_\_\_\_\_

\*\*\*\*\*

(IF A CO-PARTNERSHIP)

FIRM NAME \_\_\_\_\_ (SEAL)

SIGNED BY \_\_\_\_\_ (SEAL)

BUSINESS ADDRESS \_\_\_\_\_

\_\_\_\_\_

Insert Names and \_\_\_\_\_  
Addresses of All \_\_\_\_\_  
Members of the firm \_\_\_\_\_

\*\*\*\*\*

(IF A CORPORATION)

CORPORATE NAME \_\_\_\_\_

SIGNED BY \_\_\_\_\_

President

BUSINESS ADDRESS \_\_\_\_\_

\_\_\_\_\_

(CORPORATE SEAL)

PRESIDENT \_\_\_\_\_

Insert Names of Officers SECRETARY \_\_\_\_\_

TREASURER \_\_\_\_\_

ATTEST: \_\_\_\_\_

Secretary



CONTRACT SPECIFICATION - DEVIATIONS AND SUBSTITUTIONS

Pursuant to Section 15 of the Instructions to Bidders, please list any and all deviations and substitutions made in the Contract Specifications here:

All deviations or substitutions must meet or exceed the specifications.

SUBMITTED BY:

\_\_\_\_\_  
Print Name of Company

BY: \_\_\_\_\_  
Signature of person authorized to sign bid

TITLE \_\_\_\_\_

ADDRESS \_\_\_\_\_

\_\_\_\_\_

E-MAIL ADDRESS: \_\_\_\_\_

PHONE (\_\_\_\_\_) \_\_\_\_\_

DATE \_\_\_\_\_

(NOTE: These affidavits must be completed by an authorized representative of the bidder)

**AFFIDAVITS**

***Business Status of Bidder***

**BIDDER/APPLICANT:**

\_\_\_\_\_  
*Name*

\_\_\_\_\_  
*Principal place of business*

\_\_\_\_\_  
*Address*

\_\_\_\_\_  
*City, State, Zip Code*

***The Bidder is a:***

- \_\_\_\_\_ *Corporation*
- \_\_\_\_\_ *Partnership*
- \_\_\_\_\_ *Limited Liability Company*
- \_\_\_\_\_ *Sole Proprietorship*
- \_\_\_\_\_ *Other (please explain: \_\_\_\_\_)*

***Corporation***

The state of incorporation is: \_\_\_\_\_

The registered agent of the corporation in Illinois is:

\_\_\_\_\_  
*Name*

\_\_\_\_\_  
*Address*

\_\_\_\_\_  
*City, State, Zip*

The officers of the corporation are:

\_\_\_\_\_  
*President*

\_\_\_\_\_  
*Secretary*

\_\_\_\_\_  
*Vice President*

\_\_\_\_\_  
*Treasurer*

The Corporation is authorized to do business in the State of Illinois

***Limited Liability Company***

The state of registration is: \_\_\_\_\_

The registered agent of the Limited Liability Company in Illinois is:

*Name* \_\_\_\_\_

*Address* \_\_\_\_\_

*City State Zip* \_\_\_\_\_

The registered office of the Limited Liability Company in Illinois is:

*Address* \_\_\_\_\_

*City State Zip* \_\_\_\_\_

The managers and members of the Limited Liability Company are:

\_\_\_\_\_  
*Name*

\_\_\_\_\_  
*Name*

\_\_\_\_\_  
*Address*

\_\_\_\_\_  
*Address*

\_\_\_\_\_  
*City, State*

\_\_\_\_\_  
*City, State*

The LLC is authorized to do business in the State of Illinois

**Sole Proprietorship**

The address of the sole proprietor is:

\_\_\_\_\_  
*Address*

\_\_\_\_\_  
*City, State*

The sole proprietor transacts business in Illinois under the following assumed names:

\_\_\_\_\_

\_\_\_\_\_

## **BID RIGGING AND BID ROTATING**

**Section 2:** That in connection with this solicitation for bids/proposals:

- A. The bid is not made in the interest of or on behalf of any undisclosed person, partnership, company, association, organization or corporation;
- B. The bidder has not in any manner directly or indirectly sought by consultation, communication or agreement with anyone to fix the bid price of said bidder or any other bidder or to fix any overhead profit or cost element of such bid price or that of any other bidder or to secure any advantage against the public body awarding the contract or anyone interested in the proper contract;
- C. The bid is genuine and not collusive or sham;
- D. The prices or breakdowns thereof and any and all contents which had been quoted in this bid have not been knowingly disclosed by the bidder and will not be knowingly disclosed by the bidder directly or indirectly to any other bidder or any competitor prior to opening;
- E. All statements contained in such bid are true;
- F. No attempt has been made or will be made by the bidder to induce any other person or firm to submit a false or sham bid;
- G. No attempt has been made or will be made by the bidder to induce any other person or firm to submit or not to submit a bid for the purpose of restricting competition;

**Section 2a**

### **NON-COLLUSION**

- A. No officer or employee of the City of Joliet has a direct or indirect pecuniary interest in this bid.
- B. No officer or employee of the City of Joliet has disclosed to the bidder any information related to the terms of a sealed bid.
- C. No officer or employee of the City of Joliet has informed the bidder that the bid will be accepted only if specified persons are included as subcontractors.
- D. Only the bidder will be entitled to the proceeds of the contract if this bid is accepted by the City of Joliet.
- E. This bid is made without the benefit of information obtained in violation of law.

- Section 3.** The undersigned further states that: (circle A or B)
- A. He is the person in the bidder's organization responsible within that organization for the decision as to the prices being bid herein and that he has not participated, and will not participate, in any action contrary to paragraphs A through G above; or
  - B. He is not the person in the bidder's organization responsible within that organization for the decision as to the prices being bid herein but that he has been authorized to act as agent for the persons responsible for such decision in certifying that such persons have not participated, and will not participate, in any action contrary to paragraphs A through G above and as their agent does hereby so certify; and
  - C. That he has not participated, and will not participate, in any action contrary to paragraphs A through G above.
- Section 4.** The undersigned certifies that the bidder has never been convicted for a violation of State laws prohibiting bid rigging or bid rotating.

**THE REQUIREMENTS OF THE  
ILLINOIS DRUG FREE WORKPLACE ACT**

- Section 5.** The undersigned will publish a statement:
- A. Notifying employees that the unlawful manufacture, distribution, dispensation, possession, or use of a controlled substance is prohibited in the aforementioned company's workplace;
  - B. Specifying the actions that will be taken against employees for violations of this prohibition;
  - C. Notifying the employees that, as a condition of their employment to do work under the contract with the City of Joliet, the employees will:
    - 1. Abide by the terms of the statement; and
    - 2. Notify the aforementioned company of any criminal drug statute conviction for a violation occurring in the workplace not later than five (5) days after such a conviction.
  - D. Establishing a drug free awareness program to inform the aforementioned company's employees about:

1. The dangers of drug abuse in the workplace;
  2. The aforementioned company's policy of maintaining a drug free workplace;
  3. Any available drug counseling, rehabilitation, and employee assistance programs; and
  4. The penalties that may be imposed upon employees for drug violations.
- E. Making it a requirement to give a copy of the statement required by Section 5. to each employee engaged in the performance of the contract with the City of Joliet and to post the statement in a prominent place in the workplace;
- F. Notifying the City of Joliet within ten (10) days after receiving notice under Section 5.C.2. from an employee or otherwise receiving actual notice of such a conviction;
- G. Imposing a sanction on, or requiring the satisfactory participation in a drug abuse assistance or rehabilitation program by, any employee who is so convicted, as required by Section 6., below;
- H. Training personnel to effectively assist employees in selecting a proper course of action in the event drug counseling, treatment, and rehabilitation is required and indicating that an effectively trained counseling and referral team is in place;
- I. Making a good faith effort to continue to maintain a drug free workplace through implementing these requirements.
- J. Making a good faith effort to continue to maintain a drug free workplace through implementation of this policy.

**Section 6.** The undersigned further affirms that within thirty (30) days after receiving notice from an employee of a conviction of a violation of the criminal drug statute occurring in the aforementioned company's workplace he shall:

- A. Take appropriate personnel action against such employee up to and including termination; or
- B. Require the employee to satisfactorily participate in a drug abuse assistance or rehabilitation program approved for such purposes by a federal, state, or local health, law enforcement, or other appropriate agency.

### **TAX COMPLIANCE**

**Section 7.** The undersigned on behalf of the entity making the foregoing proposal certifies that neither the undersigned nor the entity is barred from contracting with the City of Joliet because of any delinquency in the payment of any tax administered by the State of Illinois, Department of Revenue, unless the undersigned or the entity is contesting, in accordance with the procedures established by the appropriate revenue act, liability of the tax or the amount of tax.

**Section 8.** The undersigned or the entity making the proposal or bid understands that making a false statement regarding delinquency in taxes is a Class A Misdemeanor and in addition, voids the contract and allows the municipality to recover all amounts paid to the individual or entity under the contract in a civil action.

### **NON DISCRIMINATION AND EQUAL EMPLOYMENT OPPORTUNITY**

**Section 9.** This EQUAL EMPLOYMENT OPPORTUNITY CLAUSE is required by the Illinois Human Rights Act and the Rules and Regulations of the Illinois Department of Human Rights published at 44 Illinois Administrative Code Section 750, et seq.

**Section 10.** In the event of the contractor's noncompliance with any provision of this Equal Employment Opportunity Clause, the Illinois Human Right Act, or the Rules and Regulations for Public Contracts of the Department of Human Rights (hereinafter referred to as the Department) the contractor may be declared nonresponsible and therefore ineligible for future contracts or subcontracts with the State of Illinois or any of its political subdivisions or municipal corporations, and the contract may be canceled or avoided in whole or in part, and such other sanctions or penalties may be imposed or remedies involved as provided by statute or regulation.

During the performance of this contract, the contractor agrees:

- A. That it will not discriminate against any employee or applicant for employment because of race, color, religion, sex, national origin or ancestry; and further that it will examine

all job classifications to determine if minority persons or women are underutilized and will take appropriate affirmative action to rectify any such underutilization.

- B. That, if it hires additional employees in order to perform this contract, or any portion hereof, it will determine the availability (in accordance with the Department's Rules and Regulations for Public Contracts) of minorities and women in the area(s) from which it may reasonably recruit and it will hire for each job classification for which employees are hired in such a way that minorities and women are not underutilized.
- C. That, in all solicitations or advertisements for employees placed by it or on its behalf, it will state that all applicants will be afforded equal opportunity without discrimination because of race, color, religion, sex, marital status, national origin or ancestry, age, physical or mental handicap unrelated to ability, or an unfavorable discharge from military service.
- D. That it will send to each labor organization or representative of workers with which it has or is bound by a collective bargaining or other agreement or understanding, a notice advising such labor organization or representative of the contractor's obligations under the Illinois Human Rights Act and the Department's Rules and Regulations for Public Contract. If any such labor organization or representative fails or refuses to cooperate with the contractor in its efforts to comply with such Act and Rules and Regulations, the contractor will promptly so notify the Department and the contracting agency will recruit employees from other sources when necessary to fulfill its obligations thereunder.
- E. That it will submit reports as required by the Department's Rules and Regulations for Public Contracts, furnish all relevant information as may from time to time be requested by the Department or the contracting agency, and in all respects comply with the Illinois Human Rights Act and the Department's Rules and Regulations for Public Contracts.
- F. That it will permit access to all relevant books, records, accounts and work sites by personnel of the contracting agency and the Department for purposes of investigation to ascertain compliance with the Illinois Human Rights Act and the Department's Rules and Regulations for Public Contracts.
- G. That it will include verbatim or by reference the provisions of this Equal Employment Opportunity Clause in every subcontract it awards under which any portion of the contract obligations are undertaken or assumed, so that such provisions will be binding upon such subcontractor. In the same manner as the other provisions of this contract, the contractor will be liable for compliance with applicable provisions of this clause by such subcontractors; and further it will promptly notify the contracting agency and the Department in the event any subcontractor fails or refuses to comply therewith. In addition, the contractor will not utilize any subcontractor declared by the Illinois Human Rights Department to be ineligible for contracts or subcontracts with the State of Illinois or any of its political subdivisions or municipal corporations.



**Section 11.** For the purposes of subsection G of Section 10, "Subcontract" means any agreement, arrangement or understanding, written or otherwise, between a public contractor and any person under which any portion of the public contractor's obligations under one or more public contracts is performed, undertaken or assumed; the term "subcontract," however, shall not include any agreement, arrangement or understanding in which the parties stand in the relationship of an employer and an employee, or between a bank or other financial institution and its customers.

**Section 12.** It is expressly understood that the foregoing statements and representations and promises are made as a condition to the right of the bidder to receive payment under any award made under the terms and provisions of this bid.

**Section 13.** Have written sexual harassment policies that shall include, at a minimum, the following information: (i) the illegality of sexual harassment; (ii) the definition of sexual harassment under State law; (iii) a description of sexual harassment, utilizing examples; (iv) the vendor's internal complaint process including penalties; (v) the legal recourse, investigative and complaint process available through the Department and the Commission; (vi) directions on how to contact the Department and Commission; and (vii) protection against retaliation as provided by Section 6-101 of this Act. A copy of the policies shall be provided to the Department upon request.

**Section 14.** In the event that this contract is subject to Executive Order 11246, Seller certifies that it (1) is in compliance with Section 202 thereof and the Rules and Regulations issued thereunder; (2) does not and will not provide or maintain at any of its establishments, or permit its employees to perform their services at any location under its control where there are maintained, segregated facilities, and (3) agrees that a breach of this Certification violates the Equal Employment clause of Executive Order 11246. "Segregated Facilities," means facilities which are in fact segregated on a basis of race, color, creed, sex, religion or national origin, because of habit, local custom, or otherwise.

**THE AMERICANS WITH DISABILITIES ACT**

**Section 15.** As a condition of receiving this contract, the undersigned vendor certifies that services, programs and activities provided under this contract are and will continue to be in compliance with the Joliet Accessibility Code.

Signed by: \_\_\_\_\_  
[name]

\_\_\_\_\_  
[title]

Subscribed and Sworn to before me this \_\_\_\_\_ day of \_\_\_\_\_, 20\_\_.

By: \_\_\_\_\_  
Notary Public

-seal-

STATE OF ILLINOIS )  
 )  
 COUNTY OF WILL ) SS.

\*\*\*\*\*  
 \*NOTE: THIS AFFIDAVIT MUST BE  
 \*COMPLETED BY THE CHIEF OFFICER  
 \*OF THE BIDDER  
 \*\*\*\*\*

**AFFIDAVIT  
 REGARDING BIDDER AVAILABILITY**

The undersigned, \_\_\_\_\_, being first duly sworn on oath and being duly authorized to make this Affidavit, hereby declares that the following is a true and correct statement relating to All uncompleted contracts of the undersigned for Federal, State, County, City and private work, including All subcontract work; and all pending low bids not yet awarded or rejected; and equipment available.

**PART I. WORK UNDER CONTRACT**

List below all work you have under contract as either a prime contractor or a subcontractor, including all pending low bids not yet awarded or rejected.

	1	2	3	4	5	Awards Pending	
County and Section No.							
Contract With							
Estimated Completion Date							
Total Contract Price							Total
Uncompleted Dollar Value							

**PART II. UNCOMPLETED WORK TO BE DONE WITH YOUR OWN FORCES.**

List below the uncompleted dollar value of work for each contract to be completed with your own forces. All work subcontract TO others will be listed on the reverse of this form. In a joint venture list only that portion of the work to be done by your company.

							TOTALS
Excav. Grading & Clearing							
Portland Cement Concrete Paving							
Bituminous Hot Mix Surface							
Bituminous Aggregate Mix							

Aggregate Bases & Surface Structures							
Drainage							
Electrical							
Curb & Gutter							
Sewer							
Water							
Sidewalks							
Demolition							
Other/Explain							
Totals							

Date Equipment Available For Work							
--------------------------------------	--	--	--	--	--	--	--

\_\_\_\_\_  
(SIGNATURE)

\_\_\_\_\_  
(PRINT NAME)

\_\_\_\_\_  
(TITLE)

Subscribed and Sworn to before me this

\_\_\_\_\_ day of \_\_\_\_\_, AD, **20**\_\_\_\_\_.

\_\_\_\_\_  
NOTARY PUBLIC

# STOP\*

CHECK THE FOLLOWING LIST TO MAKE SURE THAT YOUR BID CONTAINS ALL OF THE REQUIRED DOCUMENTS.

- \_\_\_\_\_ 1. BID SECURITY
- \_\_\_\_\_ 2. BIDDING SCHEDULE
- \_\_\_\_\_ 3. BID PROPOSAL, DULY SIGNED
- \_\_\_\_\_ 4. ALL AFFIDAVITS, SIGNED & NOTARIZED

FAILURE TO INCLUDE ANY ONE OR ALL OF THE ABOVE MAY CONSTITUTE SUITABLE GROUNDS FOR REJECTION OF YOUR BID.

**\*(FOR CONSTRUCTION CONTRACTS ONLY)**

**AGREEMENT**

**THIS AGREEMENT** is entered into on the date stated below by and between the between the City of Joliet, an Illinois Municipal Corporation (hereinafter "City") and \_\_\_\_\_ (hereinafter "Contractor").

In consideration of the mutual promises of the parties set forth in the Contract Documents, the Contractor agrees to timely perform all work, furnish all labor and materials necessary for the proper completion of the work; and the City agrees to pay for the work as set forth in the Contract Documents. The Contractor further agrees to comply with the provisions of the *Prevailing Wage Act* (820 ILCS 130/1 et seq.).

The Contract Documents shall consist of the following documents which are hereby made part of this Agreement as if recited at length herein:

- 1) Legal Notice to Bidders
- 2) Instruction to Bidders
- 3) General and Special Conditions
- 4) Specifications and Drawings
- 5) Proposal Schedule (consistent with Contract Documents)
- 6) Affidavits
- 7) Performance Bond and Payment Bond
- 8) Addenda

**IN WITNESS WHEREOF**, the City and the Contractor, by their duly authorized representatives have hereunto set their hands this \_\_\_\_\_ day of \_\_\_\_\_, 20\_\_\_\_.

**CITY OF JOLIET,**  
**an Illinois Municipal Corporation,**

By: \_\_\_\_\_ *James D. Hock*  
*Interim City Manager*

*Print name of Contractor* \_\_\_\_\_

By: \_\_\_\_\_

*Print Name:* \_\_\_\_\_

Attest: \_\_\_\_\_  
*Christa M. Desiderio*  
*City Clerk*

*Title:* \_\_\_\_\_

**Approved as to form:**

\_\_\_\_\_  
*Sabrina Spano*  
*Corporation Counsel*