

MINOR RESIDENTIAL STREETS

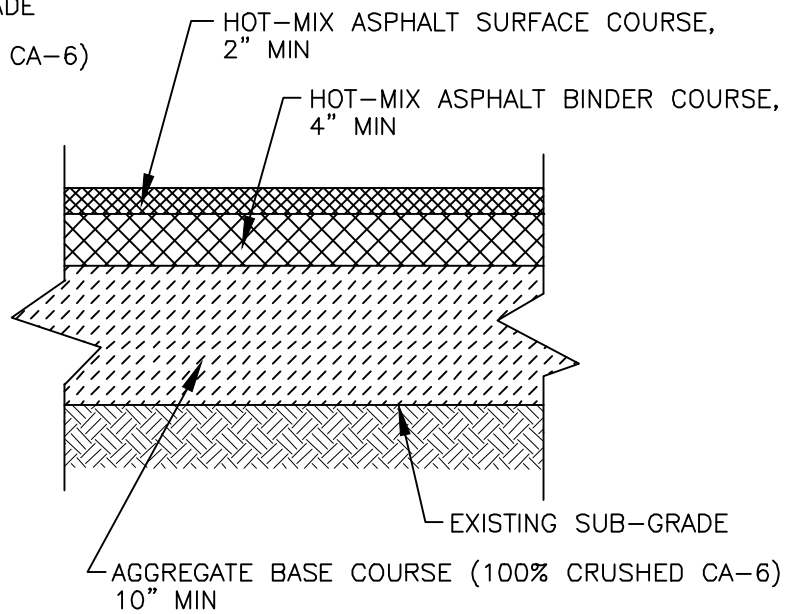

ARTERIAL STREETS

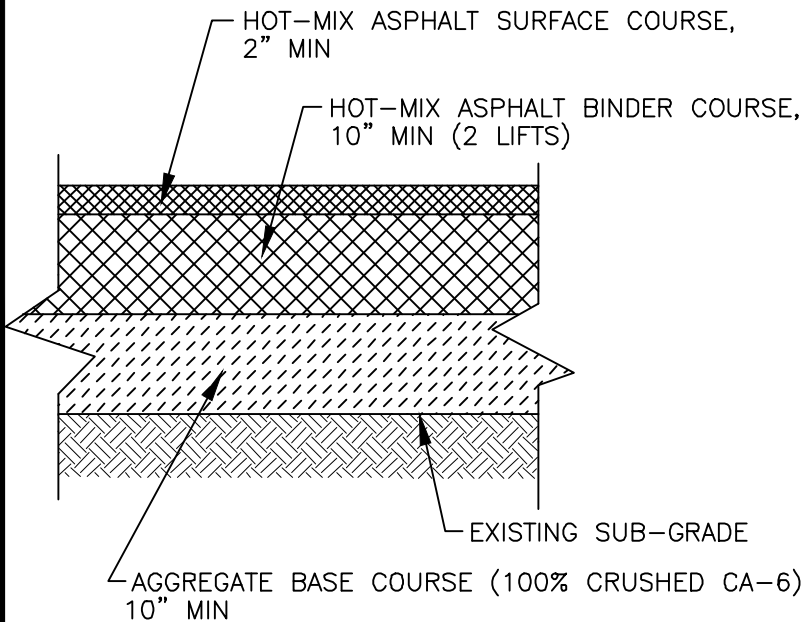

MAJOR ARTERIAL STREETS

NOTES:

1. ALL PAVEMENT PATCHES SHALL BE SAWCUT FULL-DEPTH.
2. MAXIMUM ALLOWABLE WIDTH USED FOR TRENCH RESTORATION PAY QUANTITY CALCULATIONS SHALL BE 6'.
3. DETAILS APPLY UNLESS OTHERWISE NOTED ON PLANS.

NOT TO SCALE

CITY OF JOLIET, ILLINOIS

TYPICAL PAVEMENT
SECTION
PVT-02

DATE: OCT. 2017